

P61-P65
P71-R73A

NATURAL GAS
BURNERS

MANUAL OF INSTALLATION - USE - MAINTENANCE

CIB UNIGAS

BURNERS - BRUCIATORI - BRULERS - BRENNER - QUEMADORES - ГОРЕЛКИ

WARNINGS

THIS MANUAL IS SUPPLIED AS AN INTEGRAL AND ESSENTIAL PART OF THE PRODUCT AND MUST BE DELIVERED TO THE USER.

INFORMATION INCLUDED IN THIS SECTION ARE DEDICATED BOTH TO THE USER AND TO PERSONNEL FOLLOWING PRODUCT INSTALLATION AND MAINTENANCE.

THE USER WILL FIND FURTHER INFORMATION ABOUT OPERATING AND USE RESTRICTIONS, IN THE SECOND SECTION OF THIS MANUAL. WE HIGHLY RECOMMEND TO READ IT.

CAREFULLY KEEP THIS MANUAL FOR FUTURE REFERENCE.

1) GENERAL INTRODUCTION

- The equipment must be installed in compliance with the regulations in force, following the manufacturer's instructions, by qualified personnel.
- Qualified personnel means those having technical knowledge in the field of components for civil or industrial heating systems, sanitary hot water generation and particularly service centres authorised by the manufacturer.
- Improper installation may cause injury to people and animals, or damage to property, for which the manufacturer cannot be held liable.
- Remove all packaging material and inspect the equipment for integrity.

In case of any doubt, do not use the unit - contact the supplier.

The packaging materials (wooden crate, nails, fastening devices, plastic bags, foamed polystyrene, etc), should not be left within the reach of children, as they may prove harmful.

- Before any cleaning or servicing operation, disconnect the unit from the mains by turning the master switch OFF, and/or through the cut-out devices that are provided.
- Make sure that inlet or exhaust grilles are unobstructed.
- In case of breakdown and/or defective unit operation, disconnect the unit. Make no attempt to repair the unit or take any direct action.

Contact qualified personnel only.

Units shall be repaired exclusively by a servicing centre, duly authorised by the manufacturer, with original spare parts.

Failure to comply with the above instructions is likely to impair the unit's safety.

To ensure equipment efficiency and proper operation, it is essential that maintenance operations are performed by qualified personnel at regular intervals, following the manufacturer's instructions.

- When a decision is made to discontinue the use of the equipment, those parts likely to constitute sources of danger shall be made harmless.
- In case the equipment is to be sold or transferred to another user, or in case the original user should move and leave the unit behind, make sure that these instructions accompany the equipment at all times so that they can be consulted by the new owner and/or the installer.
- For all the units that have been modified or have options fitted then original accessory equipment only shall be used.
- This unit shall be employed exclusively for the use for which it is meant. Any other use shall be considered as improper and, therefore, dangerous.

The manufacturer shall not be held liable, by agreement or otherwise, for damages resulting from improper installation, use and failure to comply with the instructions supplied by the manufacturer.

2) SPECIAL INSTRUCTIONS FOR BURNERS

- The burner should be installed in a suitable room, with ventilation openings complying with the requirements of the regulations in force, and sufficient for good combustion.
- Only burners designed according to the regulations in force should be used.
- This burner should be employed exclusively for the use for which it was designed.
- Before connecting the burner, make sure that the unit rating is the same as delivery mains (electricity, gas oil, or other fuel).
- Observe caution with hot burner components. These are, usually, near to the flame and the fuel pre-heating system, they become hot during the unit operation and will remain hot for some time after the

burner has stopped.

When the decision is made to discontinue the use of the burner, the user shall have qualified personnel carry out the following operations:

- a Remove the power supply by disconnecting the power cord from the mains.
- b) Disconnect the fuel supply by means of the hand-operated shut-off valve and remove the control handwheels from their spindles.

Special warnings

- Make sure that the burner has, on installation, been firmly secured to the appliance, so that the flame is generated inside the appliance firebox.
- Before the burner is started and, thereafter, at least once a year, have qualified personnel perform the following operations:
 - a set the burner fuel flow rate depending on the heat input of the appliance;
 - b set the flow rate of the combustion-supporting air to obtain a combustion efficiency level at least equal to the lower level required by the regulations in force;
 - c check the unit operation for proper combustion, to avoid any harmful or polluting unburnt gases in excess of the limits permitted by the regulations in force;
 - d make sure that control and safety devices are operating properly;
 - e make sure that exhaust ducts intended to discharge the products of combustion are operating properly;
 - f on completion of setting and adjustment operations, make sure that all mechanical locking devices of controls have been duly tightened;
 - g make sure that a copy of the burner use and maintenance instructions is available in the boiler room.
- In case of a burner shut-down, reset the control box by means of the RESET pushbutton. If a second shut-down takes place, call the Technical Service, **without trying to RESET further**.
- The unit shall be operated and serviced by qualified personnel only, in compliance with the regulations in force.

3) GENERAL INSTRUCTIONS DEPENDING ON FUEL USED

3a) ELECTRICAL CONNECTION

- For safety reasons the unit must be efficiently earthed and installed as required by current safety regulations.
- It is vital that all safety requirements are met. In case of any doubt, ask for an accurate inspection of electrics by qualified personnel, since the manufacturer cannot be held liable for damages that may be caused by failure to correctly earth the equipment.
- Qualified personnel must inspect the system to make sure that it is adequate to take the maximum power used by the equipment shown on the equipment rating plate. In particular, make sure that the system cable cross section is adequate for the power absorbed by the unit.
- No adaptors, multiple outlet sockets and/or extension cables are permitted to connect the unit to the electric mains.
- An omnipolar switch shall be provided for connection to mains, as required by the current safety regulations.
- The use of any power-operated component implies observance of a few basic rules, for example:
 - do not touch the unit with wet or damp parts of the body and/or with bare feet;
 - do not pull electric cables;
 - do not leave the equipment exposed to weather (rain, sun, etc.) unless expressly required to do so;
 - do not allow children or inexperienced persons to use equipment;
- The unit input cable shall not be replaced by the user.

In case of damage to the cable, switch off the unit and contact qualified

personnel to replace.

When the unit is out of use for some time the electric switch supplying all the power-driven components in the system (i.e. pumps, burner, etc.) should be switched off.

3b) FIRING WITH GAS, LIGHT OIL OR OTHER FUELS

GENERAL

- The burner shall be installed by qualified personnel and in compliance with regulations and provisions in force; wrong installation can cause injuries to people and animals, or damage to property, for which the manufacturer cannot be held liable.
- Before installation, it is recommended that all the fuel supply system pipes be carefully cleaned inside, to remove foreign matter that might impair the burner operation.
- Before the burner is commissioned, qualified personnel should inspect the following:
 - a the fuel supply system, for proper sealing;
 - b the fuel flow rate, to make sure that it has been set based on the firing rate required of the burner;
 - c the burner firing system, to make sure that it is supplied for the designed fuel type;
 - d the fuel supply pressure, to make sure that it is included in the range shown on the rating plate;
 - e the fuel supply system, to make sure that the system dimensions are adequate to the burner firing rate, and that the system is equipped with all the safety and control devices required by the regulations in force.
- When the burner is to remain idle for some time, the fuel supply tap or taps should be closed.

SPECIAL INSTRUCTIONS FOR USING GAS

Have qualified personnel inspect the installation to ensure that:

- a the gas delivery line and train are in compliance with the regulations and provisions in force;
 - b all gas connections are tight;
 - c the boiler room ventilation openings are such that they ensure the air supply flow required by the current regulations, and in any case are sufficient for proper combustion.
- Do not use gas pipes to earth electrical equipment.
 - Never leave the burner connected when not in use. Always shut the gas valve off.
 - In case of prolonged absence of the user, the main gas delivery valve to the burner should be shut off.

Precautions if you can smell gas

- a do not operate electric switches, the telephone, or any other item likely to generate sparks;
 - b immediately open doors and windows to create an air flow to purge the room;
 - c close the gas valves;
 - d contact qualified personnel.
- Do not obstruct the ventilation openings of the room where gas appliances are installed, to avoid dangerous conditions such as the development of toxic or explosive mixtures.

DIRECTIVES AND STANDARDS

Gas burners

European directives:

- Directive 2009/142/EC - Gas Appliances;
- Directive 2006/95/EC on low voltage;
- Directive 2004/108/EC on electromagnetic compatibility

Harmonised standards :

- UNI EN 676 (Gas Burners;-EN 55014-1Electromagnetic compatibility - Requirements for household appliances, electric tools and similar apparatus.
- CEI EN 60335-1(Household and similar electrical appliances - Safety. Part 1: General requirements;
- EN 50165 (Electrical equipment of non-electric appliances for household and similar purposes. Safety requirements.
- EN 60335-2-102 (Household and similar electrical appliances. Safety. Particular requirements for gas, oil and solid-fuel burning appliances having electrical connections)

Light oil burners

European directives:

- Directive 2006/95/EC on low voltage;
- Directive 2004/108/EC on electromagnetic compatibility

Harmonised standards :

- CEI EN 60335-1(Household and similar electrical appliances - Safety. Part 1: General requirements;
- UNI 267 Automatic forced draught burners for liquid fuels
- EN 55014-1Electromagnetic compatibility - Requirements for household appliances, electric tools and similar apparatus.
- EN 50165 (Electrical equipment of non-electric appliances for household and similar purposes. Safety requirements.

National standards :

- UNI 7824: Monobloc nebulizer burners for liquid fuels. Characteristics and test methods

Heavy oil burners

European directives:

- Directive 2006/95/EC on low voltage;
- Directive 2004/108/EC on electromagnetic compatibility

Harmonised standards :

- CEI EN 60335-1 Household and similar electrical appliances - SafetyPart 1: General requirements;
- EN 55014-1Electromagnetic compatibility - Requirements for household appliances, electric tools and similar apparatus.
- EN 50165 Electrical equipment of non-electric appliances for household and similar purposes. Safety requirements.

National standards :

- UNI 7824: Monobloc nebulizer burners for liquid fuels. Characteristics and test methods

Gas - Light oil burners

European directives:

- Directive 2009/142/EC - Gas Appliances;
- Directive 2006/95/EC on low voltage;
- Directive 2004/108/EC on electromagnetic compatibility

Harmonised standards :

- UNI EN 676 Gas Burners
- EN 55014-1Electromagnetic compatibility - Requirements for household appliances, electric tools and similar apparatus.
- UNI 267 Automatic forced draught burners for liquid fuels
- CEI EN 60335-1(Household and similar electrical appliances - Safety. Part 1: General requirements;
- EN 50165 Electrical equipment of non-electric appliances for household and similar purposes. Safety requirements.

National standards :

- UNI 7824: Monobloc nebulizer burners for liquid fuels. Characteristics and test methods

Gas - Heavy oil burners

European directives:

- Directive 2009/142/EC - Gas Appliances;
- Directive 2006/95/EC on low voltage;
- Directive 2004/108/EC on electromagnetic compatibility

Harmonised standards :

-EN 55014-1 Electromagnetic compatibility - Requirements for household appliances, electric tools and similar apparatus.

-UNI EN 676 (Gas Burners;

-CEI EN 60335-1 (Household and similar electrical appliances - Safety. Part 1: General requirements;

- EN 50165 Electrical equipment of non-electric appliances for household and similar purposes. Safety requirements.

National standards :

-UNI 7824: Monobloc nebulizer burners for liquid fuels. Characteristics and test methods

Industrial burners

European directives:

- Directive 2009/142/EC - Gas Appliances;

- Directive 2006/95/EC on low voltage;

- Directive 2004/108/EC on electromagnetic compatibility

Harmonised standards :

-EN 55014-1 Electromagnetic compatibility - Requirements for household appliances, electric tools and similar apparatus.

-EN 50165 Electrical equipment of non-electric appliances for household and similar purposes. Safety requirements.

-UNI EN 746-2: Industrial thermoprocessing equipment

Burner model identification

Burners are identified by burner type and model. Burner model identification is described as follows.

Type	P71	Model	M-	AB.	S.	*	A.	0.	50
(1)	(1)	(2)	(3)	(4)	(5)	(6)	(7)	(8)	(8)
(1) BURNER TYPE	P61 - P65 - P71 - R73A -								
(2) FUEL	M - Natural gas								
(3) OPERATION Available versions	AB - Double stage PR - Progressive MD - Fully modulating								
(4) BLAST TUBE	S - standard L - Extended								
(5) DESTINATION COUNTRY	* - see data plate								
(6) BURNER VERSION	A - Standard								
(7) EQUIPMENT Available version	0 = 2 valves 1 = 2 valves + gas proving system 7 = 2 valves + high gas pressure switch 8 = 2 valves + gas proving system + high gas pressure switch								
(8) GAS CONNECTION	32 = Rp1 ¹ / ₄ 40 = Rp1 ¹ / ₂ 50 = Rp2 65 = DN65 80 = DN80								

Specifications

BURNER TYPE		P61 M-...0.xx	P65 M-...0.xx
Output	min. - max. kW	160 - 800	270 - 970
Fuel		Natural gas	Natural gas
Category		see next paragraph	see next paragraph
Gas flow rate	min.-max. Stm ³ /h	17 - 84.7	28.6 - 103
Gas pressure	min.-max. mbar	(see Note 2)	(see Note 2)
Electric supply		230V 3~ / 400V 3N ~ 50Hz	230V 3~ / 400V 3N ~ 50Hz
Total power consumption	kW	1.6	2
Fan motor	kW	1.1	1.5
Protection		IP40	IP40
Weight	kg	55 - 70	60 - 80
Operation		Double stage - Progressive - Fully modulating	Double stage - Progressive - Fully modulating
Valves size/Gas connection - 32		1" ¹ / ₄ / Rp1 ¹ / ₄	1" ¹ / ₄ / Rp1 ¹ / ₄
Valves size/Gas connection - 40		1" ¹ / ₂ / Rp1 ¹ / ₂	1" ¹ / ₂ / Rp1 ¹ / ₂
Valves size/Gas connection - 50		2" / Rp2	2" / Rp2
Valves size/Gas connection - 65		2" ¹ / ₂ / DN65	2" ¹ / ₂ / DN65
Operating temperature	°C	-10 ÷ +50	-10 ÷ +50
Storage Temperature	°C	-20 ÷ +60	-20 ÷ +60
Working service*		Intermittent	Intermittent

Note1:	All gas flow rates are referred to Stm³/h (1013 mbar absolute pressure, 15 °C temperature) and are valid for G20 gas (net calorific value H_i = 34.02 MJ/Stm³)
Note2:	Maximum gas pressure = 360mbar (with Rp1"1/2 - 2" and Dungs MBDLE/MBC valves) = 500mbar (with DN65/80 and Siemens VGD / Dungs MBCvalves) Minimum gas pressure = see gas curves.

*** NOTE ON THE WORKING SERVICE:** the control box automatically stops after 24h of continuous working. The control box immediately starts up, automatically.

BURNER TYPE		P71 M...0.xx	P71 M...1.xx
Output	min. - max. kW	300 - 1.200	300 - 1650
Fuel		Natural gas	Natural gas
Category		see next paragraph	see next paragraph
Gas flow rate	min.-max. Stm ³ /h	32 - 127	32 - 174.6
Gas pressure	min.-max. mbar	(see Note 2)	(see Note 2)
Electric supply		230V 3~ / 400V 3N ~ 50Hz	230V 3~ / 400V 3N ~ 50Hz
Total power consumption	kW	2.7	2.7
Fan motor	kW	2.2	2.2
Protection		IP40	IP40
Weight	kg	80 - 115	80 - 115
Operation		Double stages - Progressive - Fully modulating	Double stages - Progressive - Fully modulating
Valves size/Gas connection - 40		1" _{1/2} / Rp1 _{1/2}	1" _{1/2} / Rp1 _{1/2}
Valves size/Gas connection - 50		2" / Rp2	2" / Rp2
Valves size/Gas connection - 65		2" _{1/2} / DN65	2" _{1/2} / DN65
Valves size/Gas connection - 80		3" / DN80	3" / DN80
Operating temperature	°C	-10 ÷ +50	-10 ÷ +50
Storage TemperatureStorage Temperature	°C	-20 ÷ +60	-20 ÷ +60
Working service*		Intermittent	Intermittent

BURNER TYPE		R73A M...1.50	R73A M...1.65	R73A M...1.80
Output	min. - max. kW	320 - 2050		
Fuel		Natural gas		
Category		see next paragraph		
Gas flow rate	min.-max. Stm ³ /h	34 - 217		
Gas pressure	min.-max. mbar	(see Note 2)		
Electric supply		230V 3~ / 400V 3N ~ 50Hz		
Total power consumption	kW	3.5		
Fan motor	kW	3		
Protection		IP40		
Weight	kg	90	110	120
Operation		Double stages - Progressive - Fully modulating		
Valves size/Gas connection		2" / Rp2	2" _{1/2} / DN65	3" / DN80
Operating temperature	°C	-10 ÷ +50		
Storage TemperatureStorage Temperature	°C	-20 ÷ +60		
Working service*		Intermittent		

Note1:	All gas flow rates are referred to Stm ³ /h (1013 mbar absolute pressure, 15 °C temperature) and are valid for G20 gas (net calorific value H _i = 34.02 MJ/Stm ³)
Note2:	Maximum gas pressure = 360mbar (with Rp1"1/2 - 2" and Dungs MBDLE/MBC valves) = 500mbar (with DN65/80 and Siemens VGD / Dungs MBCvalves) Minimum gas pressure = see gas curves.

* NOTE ON THE WORKING SERVICE: the control box automatically stops after 24h of continuous working. The control box immediately starts up, automatically.

Country and usefulness gas categories

GAS CATEGORY	COUNTRY																								
	AT	ES	GR	SE	FI	IE	HU	IS	NO	CZ	DK	GB	IT	PT	CY	EE	LV	SI	MT	SK	BG	LT	RO	TR	CH
I _{2H}																									
I _{2E}	LU	PL	-	-	-	-	-	-	-	-	-	-	-	-	-	-	-	-	-	-	-	-	-	-	-
I _{2E(R)B}	BE	-	-	-	-	-	-	-	-	-	-	-	-	-	-	-	-	-	-	-	-	-	-	-	-
I _{2L}	NL	-	-	-	-	-	-	-	-	-	-	-	-	-	-	-	-	-	-	-	-	-	-	-	-
I _{2ELL}	DE	-	-	-	-	-	-	-	-	-	-	-	-	-	-	-	-	-	-	-	-	-	-	-	-
I _{2Er}	FR	-	-	-	-	-	-	-	-	-	-	-	-	-	-	-	-	-	-	-	-	-	-	-	-

Overall dimensions (mm)

Burner: P61

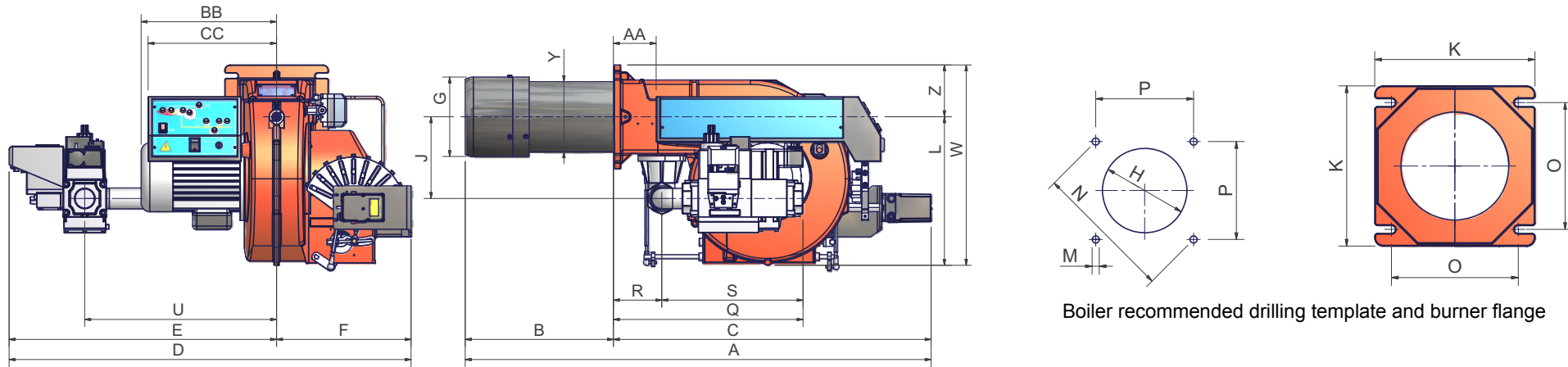

Boiler recommended drilling template and burner flange

	DN	A(S*)	A(L*)	AA	B(S*)	B(L*)	BB	C	CC	D	E	F	G	H	J	K	L	M	N	O	P	Q	R	S	U	V**	W	Y	Z
P61 PR - 0.32	32	1079	1169	99	343	433	314	736	298	812	500	312	184	204	210	240	344	M10	269	190	190	341	112	229	444	-	464	162	120
P61 MD - 0.32	32	1079	1169	99	343	433	314	736	298	812	500	312	184	204	210	240	344	M10	269	190	190	341	112	229	444	-	464	162	120
P61 AB - 0.32	32	1009	1099	99	343	433	314	666	298	812	500	312	184	204	210	240	344	M10	269	190	190	341	112	229	444	-	464	162	120
P61 PR - 0.40	40	1079	1169	99	343	433	314	736	298	812	500	312	184	204	210	240	344	M10	269	190	190	439	112	327	444	-	464	162	120
P61 MD - 0.40	40	1079	1169	99	343	433	314	736	298	812	500	312	184	204	210	240	344	M10	269	190	190	439	112	327	444	-	464	162	120
P61 AB - 0.40	40	1009	1099	99	343	433	314	666	298	812	500	312	184	204	210	240	344	M10	269	190	190	439	112	327	444	-	464	162	120
P61 PR - 0.50	50	1079	1169	99	343	433	314	736	298	812	500	312	184	204	210	240	344	M10	269	190	190	447	112	335	444	-	464	162	120
P61 MD - 0.50	50	1079	1169	99	343	433	314	736	298	812	500	312	184	204	210	240	344	M10	269	190	190	447	112	335	444	-	464	162	120
P61 AB - 0.50	50	1009	1099	99	343	433	314	666	298	812	500	312	184	204	210	240	344	M10	269	190	190	447	112	335	444	-	464	162	120
P61 PR - 0.65	65	1079	1169	99	343	433	314	736	298	997	685	312	184	204	250	240	420	M10	269	190	190	515	112	403	540	313	540	162	120
P61 MD - 0.65	65	1079	1169	99	343	433	314	736	298	997	685	312	184	204	250	240	420	M10	269	190	190	515	112	403	540	313	540	162	120
P61 AB - 0.65	65	1009	1099	99	343	433	314	666	298	997	685	312	184	204	250	240	420	M10	269	190	190	515	112	403	540	313	540	162	120

*S = measure referred to burner fitted with standard blast tube

*L = measure referred to burner fitted with extended blast tube

**V measure stands for the gas filter when not built-in the gas valves (VGD or MBC valves from DN65 on).

Note: the gas proving system is an option.

Burners: P65 - P71

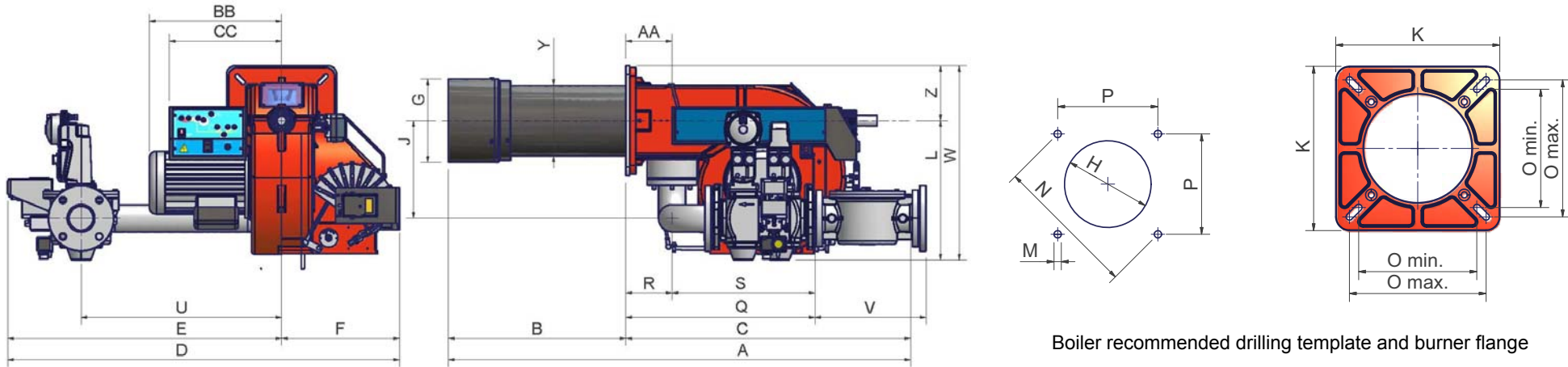

Boiler recommended drilling template and burner flange

	DN	A(S*)	A(L*)	AA	B(S*)	B(L*)	BB	C	CC	D	E	F	G	H	J	K	L	M	N	Omin	Omax	P	Q	R	S	U	V**	W	Y	Z
P65 PR - 0.32	32	1129	1219	130	326	416	373	803	316	900	568	332	184	228	208	300	376	M10	330	216	250	233	367	130	237	465	-	531	198	155
P65 PR - 1.32	32	1129	1219	130	326	416	373	803	316	1026	694	332	184	228	208	300	376	M10	330	216	250	233	367	130	237	465	-	531	198	155
P65 AB - 0.32	32	1129	1219	130	326	416	373	733	316	900	568	332	184	228	208	300	376	M10	330	216	250	233	367	130	237	465	-	531	198	155
P65 AB - 1.32	32	1129	1219	130	326	416	373	733	316	1026	694	332	184	228	208	300	376	M10	330	216	250	233	367	130	237	465	-	531	198	155
P65 MD - 0.32	32	1129	1219	130	326	416	373	803	316	900	568	332	184	228	208	300	376	M10	330	216	250	233	367	130	237	465	-	531	198	155
P65 MD - 1.32	32	1129	1219	130	326	416	373	803	316	1026	694	332	184	228	208	300	376	M10	330	216	250	233	367	130	237	465	-	531	198	155
P65 PR - 0.40	40	1129	1219	130	326	416	373	803	316	900	568	332	184	228	208	300	376	M10	330	216	250	233	465	130	335	465	-	531	198	155
P65 PR - 1.40	40	1129	1219	130	326	416	373	803	316	1026	694	332	184	228	208	300	376	M10	330	216	250	233	465	130	335	465	-	531	198	155
P65 AB - 0.40	40	1129	1219	130	326	416	373	733	316	900	568	332	184	228	208	300	376	M10	330	216	250	233	465	130	335	465	-	531	198	155
P65 AB - 1.40	40	1129	1219	130	326	416	373	733	316	1026	694	332	184	228	208	300	376	M10	330	216	250	233	465	130	335	465	-	531	198	155
P65 MD - 0.40	40	1129	1219	130	326	416	373	803	316	900	568	332	184	228	208	300	376	M10	330	216	250	233	465	130	335	465	-	531	198	155
P65 MD - 1.40	40	1129	1219	130	326	416	373	803	316	1026	694	332	184	228	208	300	376	M10	330	216	250	233	465	130	335	465	-	531	198	155
P65 PR - 0.50	50	1129	1219	130	326	416	373	803	316	900	568	332	184	228	208	300	376	M10	330	216	250	233	465	130	335	465	-	531	198	155
P65 PR - 1.50	50	1129	1219	130	326	416	373	803	316	1026	694	332	184	228	208	300	376	M10	330	216	250	233	465	130	335	465	-	531	198	155
P65 AB - 0.50	50	1129	1219	130	326	416	373	733	316	900	568	332	184	228	208	300	376	M10	330	216	250	233	465	130	335	465	-	531	198	155
P65 AB - 1.50	50	1129	1219	130	326	416	373	733	316	1026	694	332	184	228	208	300	376	M10	330	216	250	233	465	130	335	465	-	531	198	155
P65 MD - 0.50	50	1129	1219	130	326	416	373	803	316	900	568	332	184	228	208	300	376	M10	330	216	250	233	465	130	335	465	-	531	198	155
P65 MD - 1.50	50	1129	1219	130	326	416	373	803	316	1026	694	332	184	228	208	300	376	M10	330	216	250	233	465	130	335	465	-	531	198	155
P65 PR - 0.65	65	1129	1219	130	326	416	373	803	316	998	666	332	184	228	273	300	393	M10	330	216	250	233	533	130	403	533	313	548	198	155
P65 PR - 1.65	65	1129	1219	130	326	416	373	803	316	1104	772	332	184	228	273	300	393	M10	330	216	250	233	533	130	403	533	313	548	198	155
P65 AB - 0.65	65	1129	1219	130	326	416	373	733	316	998	666	332	184	228	273	300	393	M10	330	216	250	233	533	130	403	533	313	548	198	155
P65 AB - 1.65	65	1129	1219	130	326	416	373	733	316	1104	772	332	184	228	273	300	393	M10	330	216	250	233	533	130	403	533	313	548	198	155
P65 MD - 0.65	65	1129	1219	130	326	416	373	803	316	998	666	332	184	228	273	300	393	M10	330	216	250	233	533	130	403	533	313	548	198	155
P65 MD - 1.65	65	1129	1219	130	326	416	373	803	316	1104	772	332	184	228	273	300	393	M10	330	216	250	233	533	130	403	533	313	548	198	155

*S = measure referred to burner fitted with standard blast tube *L = measure referred to burner fitted with extended blast tube **V measure stands for the gas filter when not built-in the gas valves (VGD or MBC valves from DN65 on).

Note: the gas proving system is an option.

	DN	A(S*)	A(L*)	AA	B(S*)	B(L*)	BB	C	CC	D	E	F	G	H	J	K	L	M	N	Omin	Omax	P	Q	R	S	U	V**	W	Y(*S)	Y(*L)	Z
P71 PR - 0.40	40	1188	1298	130	385	495	373	803	316	900	568	332	234	264	208	300	376	M10	330	216	250	233	457	130	327	519	x	531	198	212	155
P71 PR - 1.40	40	1188	1298	130	385	495	373	803	316	1026	694	332	234	264	208	300	376	M10	330	216	250	233	457	130	327	519	x	531	198	212	155
P71 AB - 0.40	40	1118	1228	130	385	495	373	733	316	900	568	332	234	264	208	300	376	M10	330	216	250	233	457	130	327	519	x	531	198	212	155
P71 AB - 1.40	40	1118	1228	130	385	495	373	733	316	1026	694	332	234	264	208	300	376	M10	330	216	250	233	457	130	327	519	x	531	198	212	155
P71 MD - 0.40	40	1188	1298	130	385	495	373	803	316	900	568	332	234	264	208	300	376	M10	330	216	250	233	457	130	327	519	x	531	198	212	155
P71 MD - 1.40	40	1188	1298	130	385	495	373	803	316	1026	694	332	234	264	208	300	376	M10	330	216	250	233	457	130	327	519	x	531	198	212	155
P71 PR - 0.50	50	1188	1298	130	385	495	373	803	316	900	568	332	234	264	208	300	376	M10	330	216	250	233	465	130	335	519	x	531	198	212	155
P71 PR - 1.50	50	1188	1298	130	385	495	373	803	316	1026	694	332	234	264	208	300	376	M10	330	216	250	233	465	130	335	519	x	531	198	212	155
P71 AB - 0.50	50	1118	1228	130	385	495	373	733	316	900	568	332	234	264	208	300	376	M10	330	216	250	233	465	130	335	519	x	531	198	212	155
P71 AB - 1.50	50	1118	1228	130	385	495	373	733	316	1026	694	332	234	264	208	300	376	M10	330	216	250	233	465	130	335	519	x	531	198	212	155
P71 MD - 0.50	50	1188	1298	130	385	495	373	803	316	900	568	332	234	264	208	300	376	M10	330	216	250	233	465	130	335	519	x	531	198	212	155
P71 MD - 1.50	50	1188	1298	130	385	495	373	803	316	1026	694	332	234	264	208	300	376	M10	330	216	250	233	465	130	335	519	x	531	198	212	155
P71 PR - 0.65	65	1188	1298	130	385	495	373	803	316	998	666	332	234	264	275	300	393	M10	330	216	250	233	533	130	403	565	313	548	198	212	155
P71 PR - 1.65	65	1188	1298	130	385	495	373	803	316	1104	772	332	234	264	275	300	393	M10	330	216	250	233	533	130	403	565	313	548	198	212	155
P71 AB - 0.65	65	1118	1228	130	385	495	373	733	316	998	666	332	234	264	275	300	393	M10	330	216	250	233	533	130	403	565	313	548	198	212	155
P71 AB - 1.65	65	1118	1228	130	385	495	373	733	316	1104	772	332	234	264	275	300	393	M10	330	216	250	233	533	130	403	565	313	548	198	212	155
P71 MD - 0.65	65	1188	1298	130	385	495	373	803	316	998	666	332	234	264	275	300	393	M10	330	216	250	233	533	130	403	565	313	548	198	212	155
P71 MD - 1.65	65	1188	1298	130	385	495	373	803	316	1104	772	332	234	264	275	300	393	M10	330	216	250	233	533	130	403	565	313	548	198	212	155
P71 PR - 0.80	80	1188	1298	130	385	495	373	803	316	998	666	332	234	264	275	300	407	M10	330	216	250	233	574	130	444	565	344	562	198	212	155
P71 PR - 1.80	80	1188	1298	130	385	495	373	803	316	1106	774	332	234	264	275	300	407	M10	330	216	250	233	574	130	444	565	344	562	198	212	155
P71 AB - 0.80	80	1118	1228	130	385	495	373	733	316	998	666	332	234	264	275	300	407	M10	330	216	250	233	574	130	444	565	344	562	198	212	155
P71 AB - 1.80	80	1118	1228	130	385	495	373	733	316	1106	774	332	234	264	275	300	407	M10	330	216	250	233	574	130	444	565	344	562	198	212	155
P71 MD - 0.80	80	1188	1298	130	385	495	373	803	316	998	666	332	234	264	275	300	407	M10	330	216	250	233	574	130	444	565	344	562	198	212	155
P71 MD - 1.80	80	1188	1298	130	385	495	373	803	316	1106	774	332	234	264	275	300	407	M10	330	216	250	233	574	130	444	565	344	562	198	212	155

*S = measure referred to burner fitted with standard blast tube

*L = measure referred to burner fitted with extended blast tube

** measure "V" refers to gas filter dimensions, when it is not built-in in the gas valves (i.e. VGD gas valves or MBC valves from DN65 on).

R73A

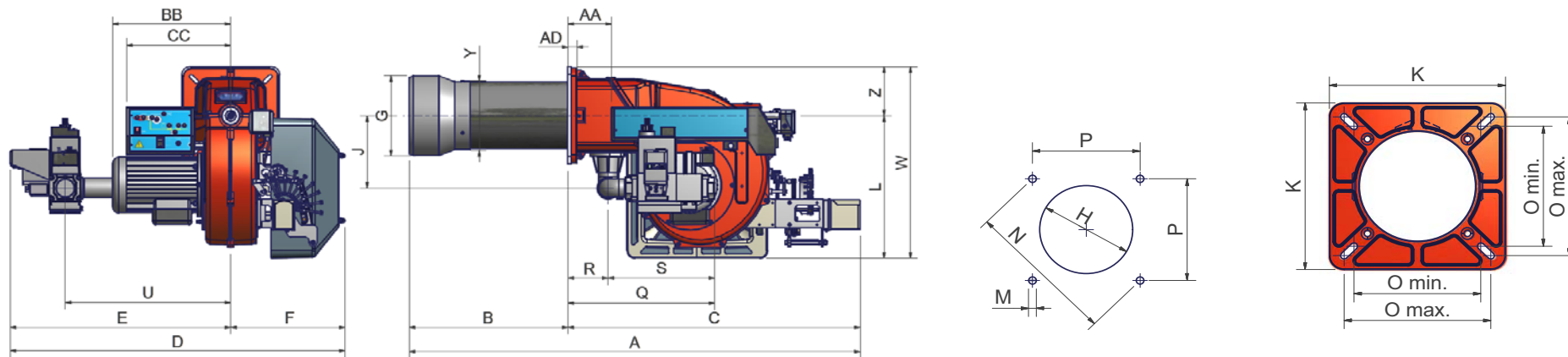

Boiler recommended drilling template and burner flange

	DN	A	AA	AD	B	BB	C	CC	D	E	F	G	H	J	K	L	M	N	Omin	Omax	P	Q	R	S	U	V	W	Y	Z
R73A PR - 1.50	50	1429	138	28	503	374	926	330	1060	699	361	254	270	230	300	453	M10	330	216	250	233	465	127	338	524	x	608	221	155
R73A MD - 1.50	50	1429	138	28	503	374	926	330	1060	699	361	254	270	230	300	453	M10	330	216	250	233	465	127	338	524	x	608	221	155
R73A PR - 1.65	65	1429	138	28	503	374	926	330	1133	772	361	254	270	284	300	453	M10	330	216	250	233	530	127	403	565	313	608	221	155
R73A MD - 1.65	65	1429	138	28	503	374	926	330	1133	772	361	254	270	284	300	453	M10	330	216	250	233	530	127	403	565	313	608	221	155
R73A PR - 1.80	80	1429	138	28	503	374	926	330	1135	774	361	254	270	284	300	453	M10	330	216	250	233	571	127	444	565	344	608	221	155
R73A MD - 1.80	80	1429	138	28	503	374	926	330	1135	774	361	254	270	284	300	453	M10	330	216	250	233	571	127	444	565	344	608	221	155
R73A PR - 1.100	100	1429	138	28	503	374	926	330	1410	1049	361	254	270	443	300	453	M10	330	216	250	233	650	127	523	824	405	608	221	155
R73A MD - 1.100	100	1429	138	28	503	374	926	330	1410	1049	361	254	270	443	300	453	M10	330	216	250	233	650	127	523	824	405	608	221	155

Performance curves

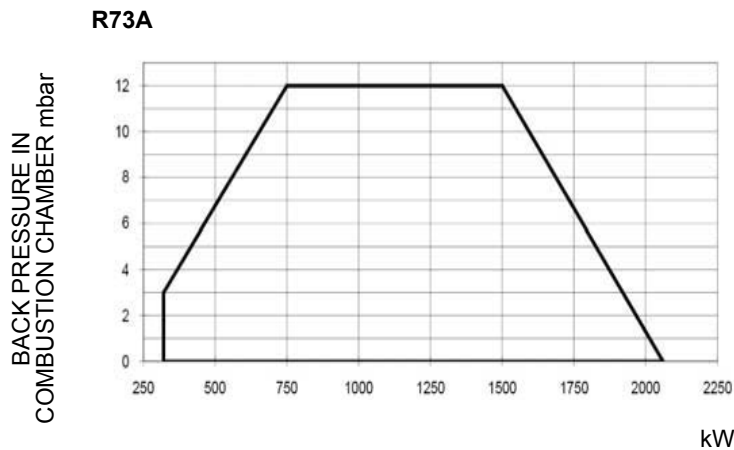
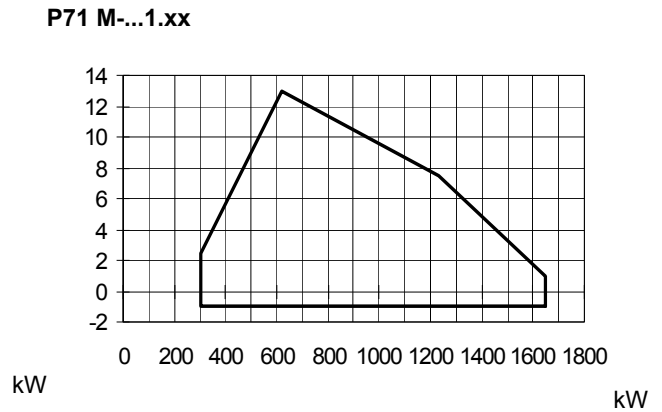
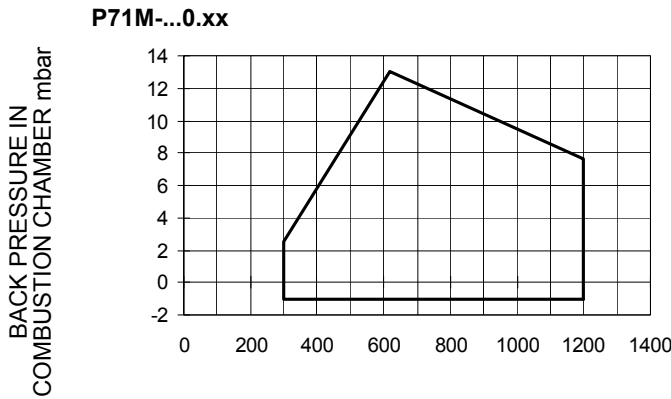
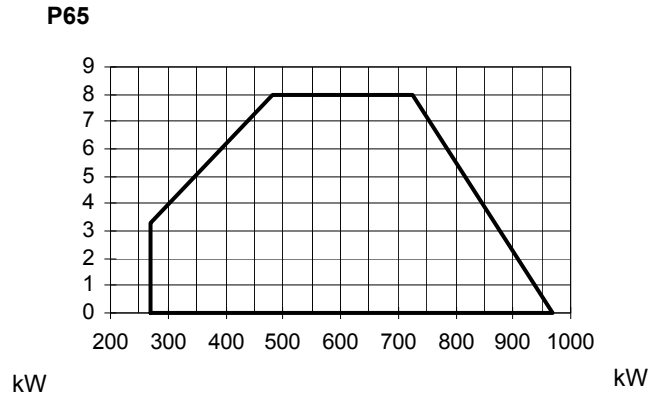
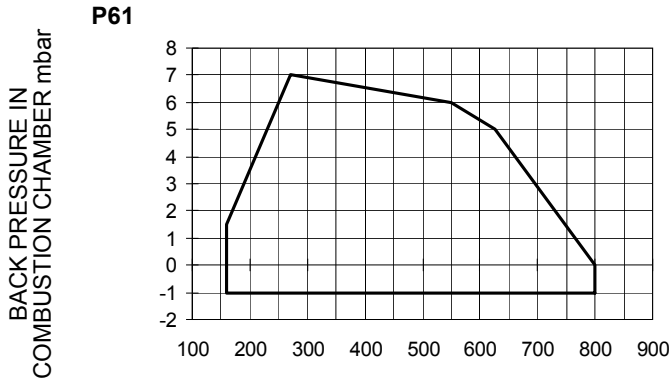

To get the input in kcal/h, multiply value in kW by 860.

Data are referred to standard conditions: atmospheric pressure at 1013mbar, ambient temperature at 15°C.

NOTE: The performance curve is a diagram that represents the burner performance in the type approval phase or in the laboratory tests, but does not represent the regulation range of the machine. On this diagram the maximum output point is usually reached by adjusting the combustion head to its "MAX" position (see paragraph "Adjusting the combustion head"); the minimum output point is reached setting the combustion head to its "MIN" position. During the first ignition, the combustion head is set in order to find a compromise between the burner output and the generator specifications, that is why the minimum output may be different from the Performance curve minimum.

Pressure in the network - gas flow rate curves

P61

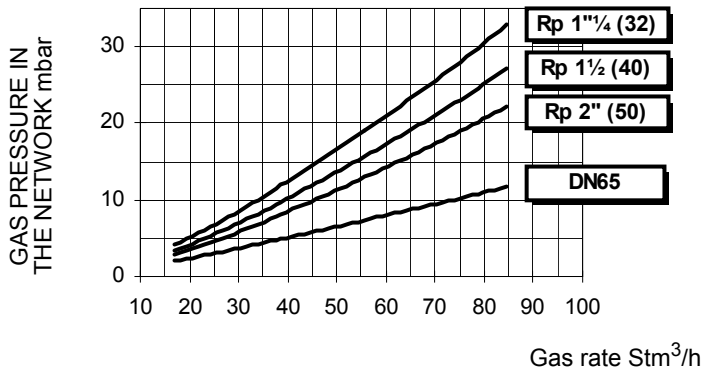

P65

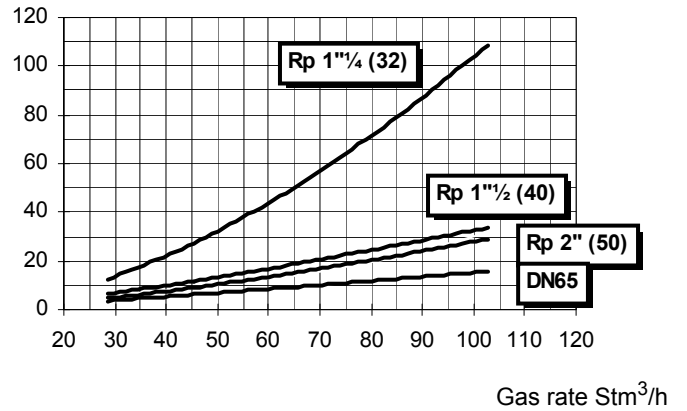

P71 M-...0.xx

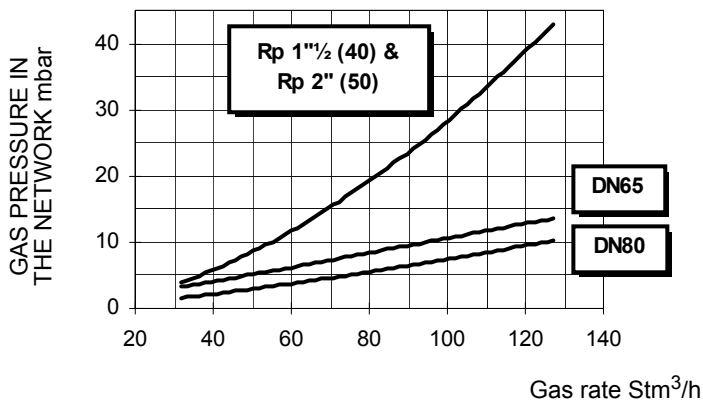

P71 M-...1.xx

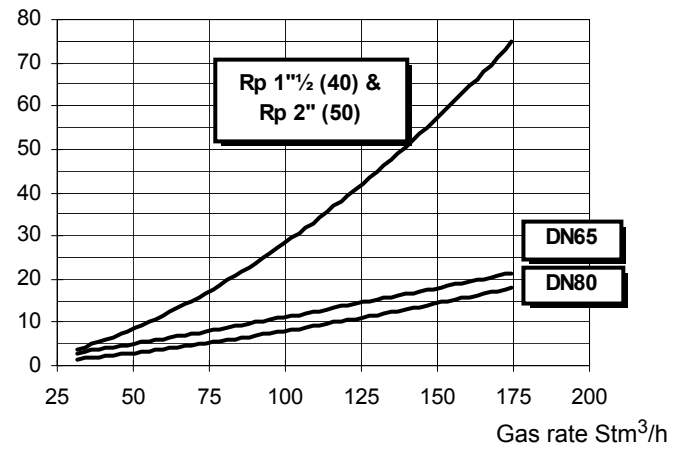

R73A M-...1.xx

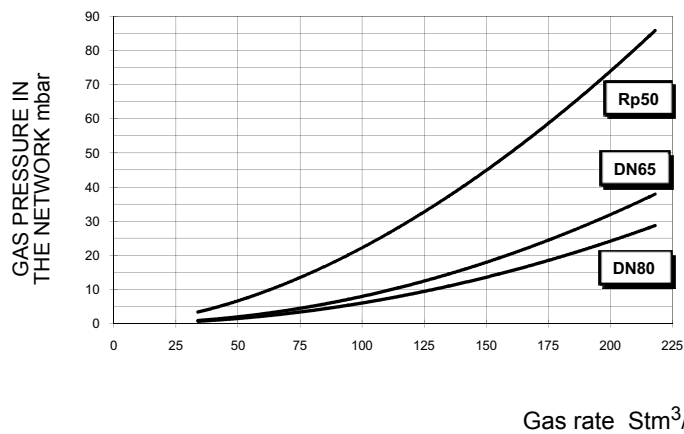

 Caution: the gas rate value is quoted on the x-axis, the related network pressure is quoted on the y-axis (pressure value in the combustion chamber is not included). To know the minimum pressure at the gas train inlet, necessary to get the requested gas rate, add the pressure value in the combustion chamber to the value read on the y-axis.

MOUNTINGS AND CONNECTIONS

Packing

Burners are despatched in cardboard packages whose dimensions are:

- P61: 1200mm x 670mm x 540mm (L x P x H).
- P65 - P71 - R73A: 1280mm x 850mm x 760mm (L x P x H).

Packing cases of this type are affected by humidity; the maximum number of cases to be stacked is shown outside the packing. The following are placed in each packing case.

- burner with gas train;
- gasket to be inserted between the burner and the boiler;
- envelope containing this manual

To get rid of the burner's packing, follow the procedures laid down by current laws on disposal of materials.

Handling the burner

	ATTENTION! The handling operations must be carried out by specialised and trained personnel. If these operations are not carried out correctly, the residual risk for the burner to overturn and fall down still persists.
	To move the burner, use means suitable to support its weight (see paragraph "Technical specifications").
	The unpacked burner must be lifted and moved only by means of a fork lift truck.

The burner is mounted on a stirrup provided for handling the burner by means of a fork lift truck: the forks must be inserted into the A and B ways. Remove the stirrup only once the burner is installed to the boiler.

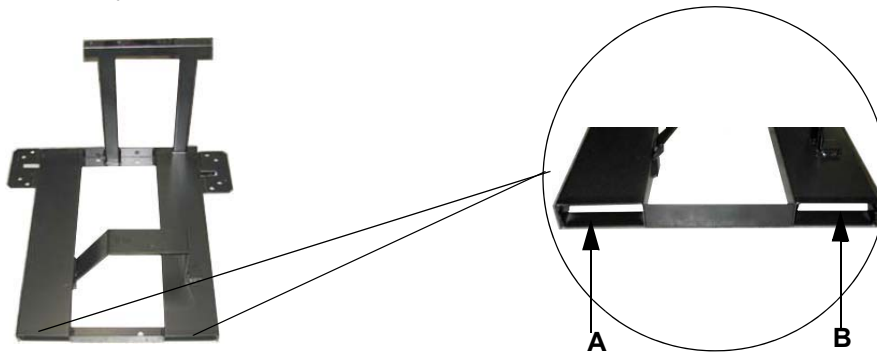

Fitting the burner to the boiler

To install the burner into the boiler, proceed as follows:

- 1 make a hole on the closing door of the combustion chamber as described on paragraph "Overall dimensions")
- 2 place the burner to the boiler: lift it up and handle it according to the procedure described on paragraph "Handling the burner";
- 3 place the 4 stud bolts (5) on boiler's door, according to the burner drilling template described on paragraph "Overall dimensions";
- 4 fasten the 4 stud bolts;
- 5 place the gasket on the burner flange;
- 6 install the burner into the boiler;
- 7 fix the burner to the stud bolts, by means of the fixing nuts, according to the next picture.
- 8 After fitting the burner to the boiler, ensure that the gap between the blast tube and the refractory lining is sealed with appropriate insulating material (ceramic fibre cord or refractory cement).

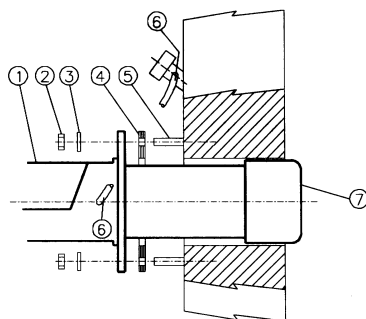

Keys

- 1 Burner
- 2 Fixing nut
- 3 Washer
- 4 Sealing gasket
- 5 Stud bolt
- 7 Blast tube

The burner is designed to work positioned according to the picture below. For different installations, please contact the Technical Department.

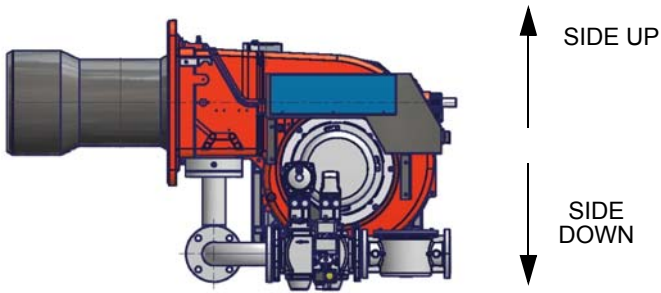

Matching the burner to the boiler

The burners described in this manual have been tested with combustion chambers that comply with EN676 regulation and whose dimensions are described in the diagram . In case the burner must be coupled with boilers with a combustion chamber smaller in diameter or shorter than those described in the diagram, please contact the supplier, to verify that a correct matching is possible, with respect of the application involved. To correctly match the burner to the boiler verify the necessary input and the pressure in combustion chamber are included in the burner performance curve; otherwise the choice of the burner must be revised consulting the burner manufacturer. To choose the blast tube lenght follow the instructions of the boiler manufacturer. In absence of these consider the following:

- Cast-iron boilers, three pass flue boilers (with the first pass in the rear part): the blast tube must protrude no more than 100 mm into the combustion chamber.
- Pressurised boilers with flame reversal: in this case the blast tube must penetrate at least 50 - 100 mm into combustion chamber in respect to the tube bundle plate.

The length of the blast tubes does not always allow this requirement to be met, and thus it may be necessary to use a suitably-sized spacer to move the burner backwards or to design a blast tube that suites the utilisation (please, contact the manufacturer).

Key

- a) Heat output in kW
- b) Length of the flame tube in meters
- c) Flame tube firing intensity in MW/m³
- d) Combustion chamber diameter (m)

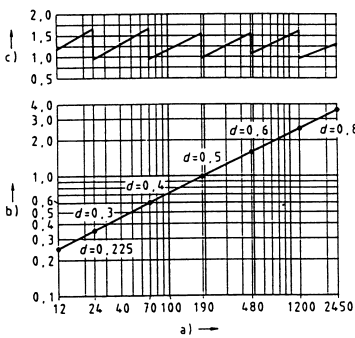

Fig. 4

Gas train connections

The next figures show the gas train components which are included in the delivery and those which must be fitted by the customer. The diagram complies with regulations in force.

ATTENTION: BEFORE EXECUTING THE CONNECTIONS TO THE GAS PIPE NETWORK, BE SURE THAT THE MANUAL CUTOFF VALVES ARE CLOSED. READ CAREFULLY THE "WARNINGS" CHAPTER AT THE BEGINNING OF THIS MANUAL.

Rp1 1/4 - Rp1 1/2 - Rp2: Gas train with valves group MB-DLE (2 valves + gas filter + pressure governor + pressure switch) + leakage control VPS504

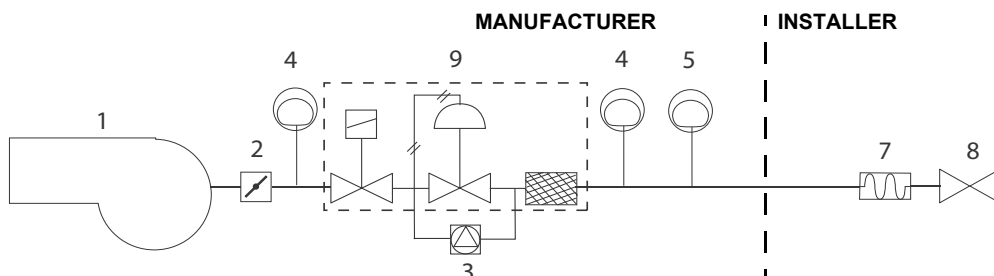

Rp2 - DN65 - DN80: Gas train with valves group VGD with built-in gas pressure governor + gas proving system VPS504

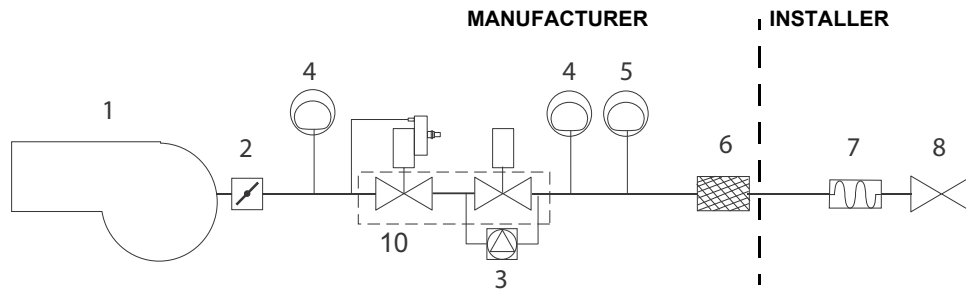

Rp2: Gas train with valves group MBC (2 valves + gas filter + pressure governor) + VPS504 gas proving system

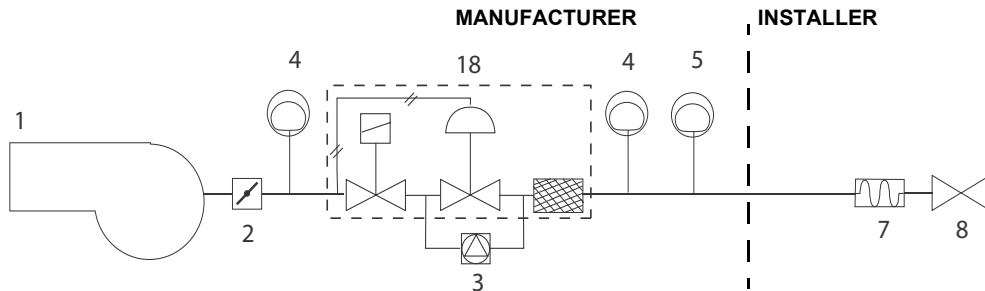

DN65 - DN80: Gas train with valves group MBC (2 valves + pressure governor) + VPS504 gas proving system

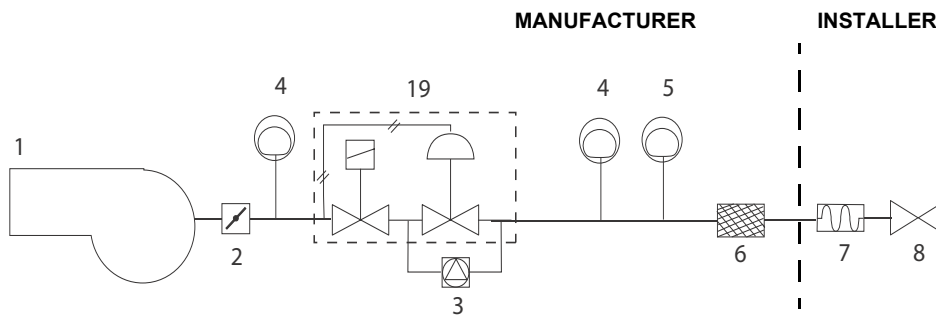

Key

- | | |
|---|--|
| 1 Burner | 7 Bellows unit |
| 2 Butterfly valve | 8 Manual valve |
| 3 Gas proving system | 9 MB-DLE Valves group |
| 4 Maximum gas pressure switch (option*) | 10 VGD Valves group |
| 5 Minimum gas pressure switch | 18 Valves group MBC (2", provided with filter) |
| 6 Gas filter | 19 Valves group MBC (an external filter must be installed) |

*Note: the maximum gas pressure switch can be mounted either upstream or downstream the gas valve but upstream the butterfly gas valve (see item no.4 in the scheme above).

Assembling the gas grain

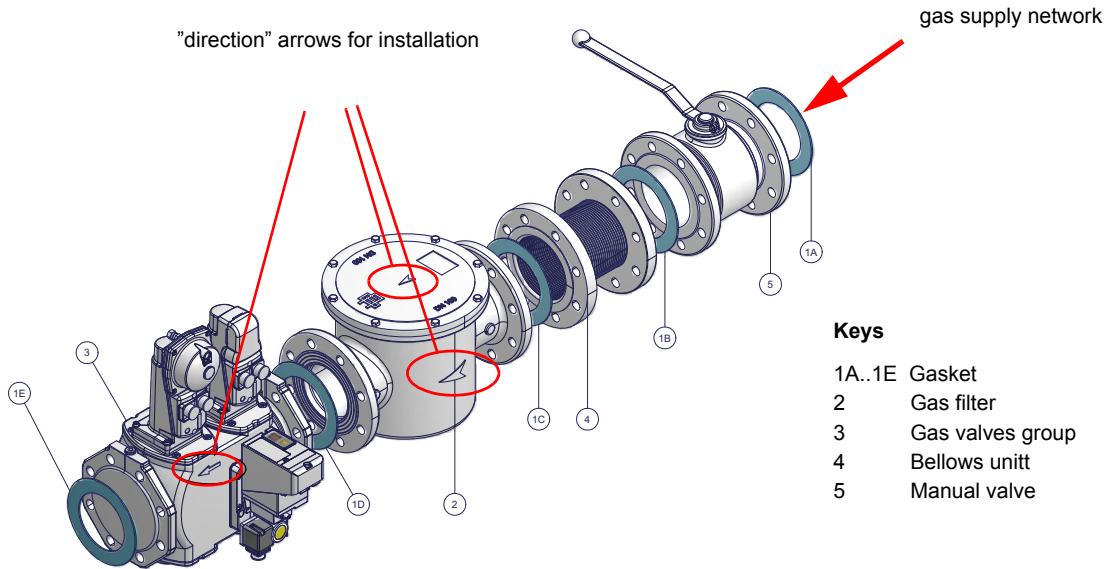

Fig. 5 - Example of gas train

To mount the gas train, proceed as follows:

- 1-a) in case of threaded joints: use proper seals according to the gas used;
- 1-b) in case of flanged joints: place a gasket (no. 1A..1E - Fig. 5) between the elements
- 2) fasten all the items by means of screws, according to the next diagrams, observing the mounting direction for each item.

NOTE: the bellows unit, the manual valve and the gaskets are not part of the standard supply.



ATTENTION: once the gas train is mounted according to the diagram (Fig. 5), the gas proving test must be performed, according to the procedure set by the laws in force.



ATTENTION: it is recommended to mount filter and gas valves to avoid that extraneous material drops inside the valves, during maintenance and cleaning operation of the filters (both the filters outside the valves group and the ones built-in the gas valves).

The procedures of installation for the gas valves are shown in the next paragraphs, according to the gas train used:

- threaded gas trains with Multibloc Dungs MB-DLE or MBC..SE 1200 or Siemens VGD20..
- flanged gas trains with Multibloc Dungs MBC..SE 1900-3100-5000 or Siemens VGD40..

MULTIBLOC DUNGS MB-DLE 405..412

Mounting

1. Mount flange onto tube lines: use appropriate sealing agent (see Fig. 8);
2. insert MB-DLE: note position of O rings (see Fig. 8);
3. tighten screws A, B, C and D (Fig. 6 - Fig. 7), according to the mounting positions (Fig. 9);
4. after installation, perform leakage and functional test;
5. disassembly in reverse order.

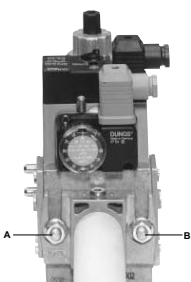

Fig. 6

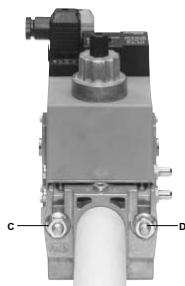

Fig. 7

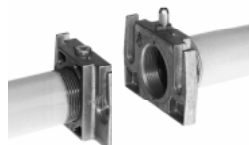

Fig. 8

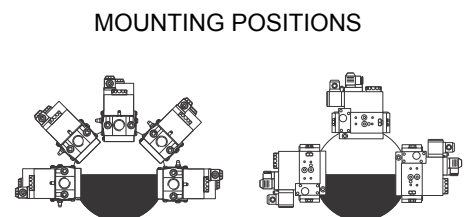

Fig. 9

MULTIBLOC DUNGS MB-DLE 415..420

Mounting

1. Loosen screws A and B **do not** unscrew (Fig. 10 - Fig. 11).
2. unscrew screws C and D (Fig. 10 - Fig. 11).
3. Remove MultiBloc between the threaded flanges (Fig. 11).
4. After mounting, perform leakage and functional tests.

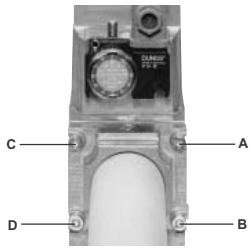

Fig. 10

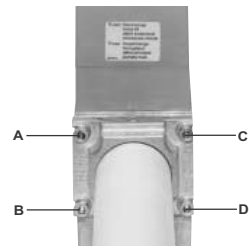

Fig. 11

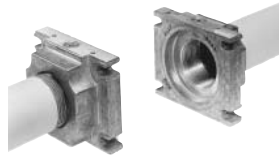

Fig. 12

MOUNTING POSITIONS

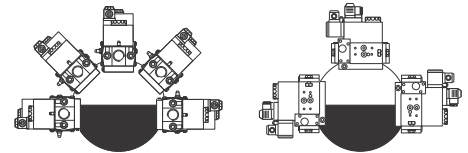

Fig. 13

MULTIBLOC DUNGS MBC300-700-1200SE (Threaded valves group)

Mounting

1. Mount flange onto tube lines. Use appropriate sealing agent (see Fig. 14)
2. Insert MBC...SE. Note position of O rings (see Fig. 15).
3. Tighten screws A – H
4. After installation, perform leakage and functional test.
5. Disassembly in reverse order



Fig. 14

MOUNTING

POSITIONS

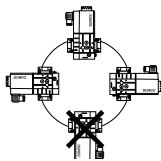
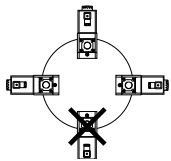

OPTION

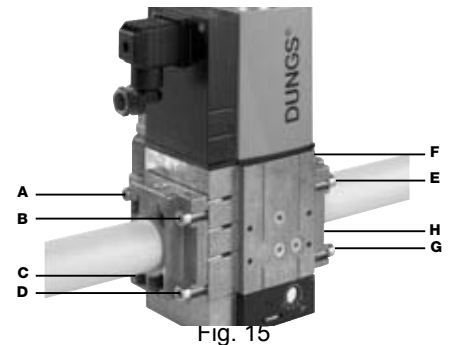
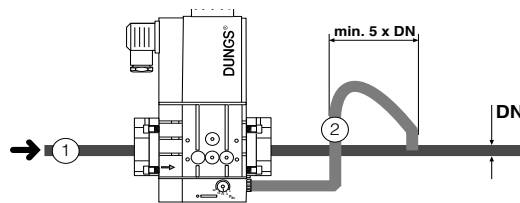

Fig. 15

MULTIBLOC DUNGS MBC1900-3100-5000SE (Flanged valves group)

Mounting

1. Insert setscrews A
 2. Insert seals
 3. Insert setscrews B
 4. Tighten setscrews A + B.
- Ensure correct seating of the seal!
6. After installation, perform leakage and functional test.
 7. Disassembly in reverse order.

Mounting positions

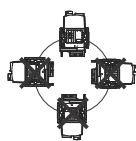
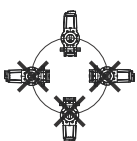

OPTION

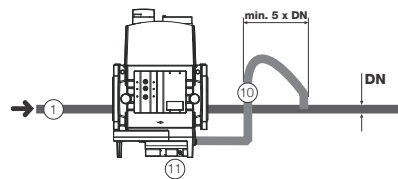

10 = pulse lines

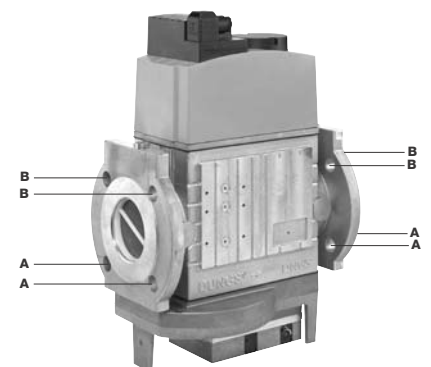

Fig. 16

Siemens VGD20.. and VGD40.. gas valves - with SKP2.. (pressure governor)

Mounting

- When mounting the VGD.. double gas valve, two flanges are required (as for VGD20.. model, the flanges are threaded);
- to prevent cuttings from falling inside the valve, first fit the flanges to the piping and then clean the associated parts;
- install the valve;

- the direction of gas flow must be in accordance with the direction of the arrow on the valve body;
 - ensure that the bolts on the flanges are properly tightened;
 - ensure that the connections with all components are tight;
 - make certain that the O-rings and gaskets between the flanges and the double gas valve are fitted.
 - Connect the reference gas pipe (**TP** in figure; 8mm-external size pipe supplied loose), to the gas pressure nipples placed on the gas pipe, downstream the gas valves: gas pressure must be measured at a distance that must be at least 5 times the pipe size.
- Leave the blowhole free (**SA** in figure). Should the spring fitted not permit satisfactory regulation, ask one of our service centres for a suitable replacement.

⚠ Caution: the SKP2 diaphragm **D** must be vertical (see Fig. 19).

⚠ WARNING: removing the four screws **BS** causes the device to be unserviceable!

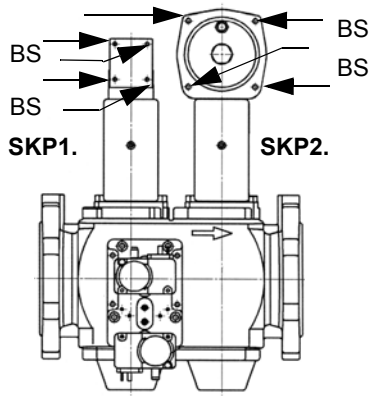

Fig. 17

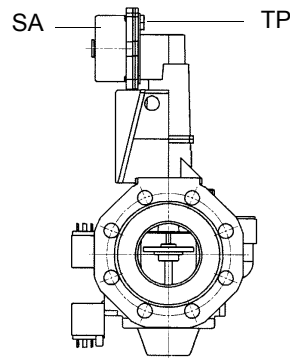

Fig. 18

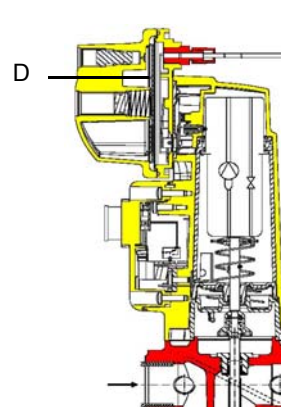

Fig. 19

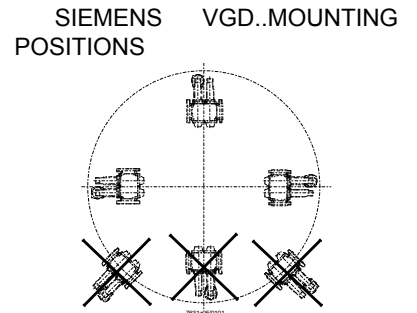

Fig. 20

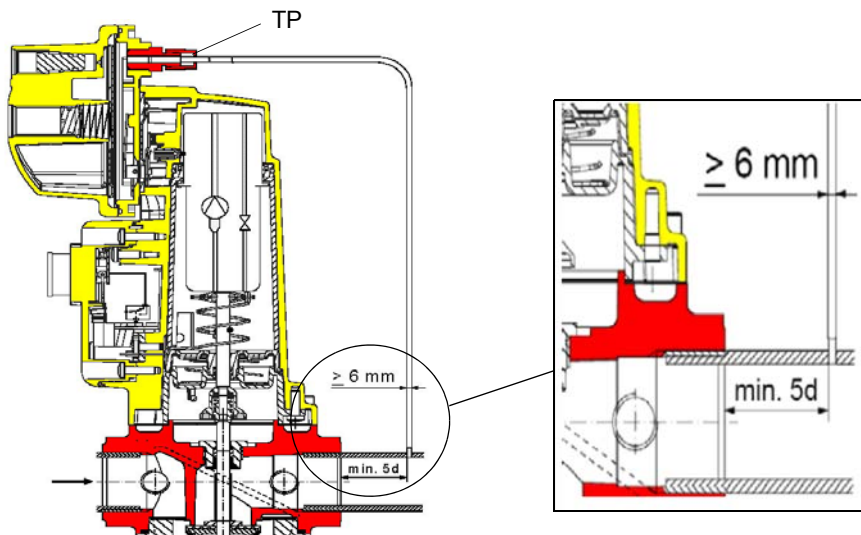
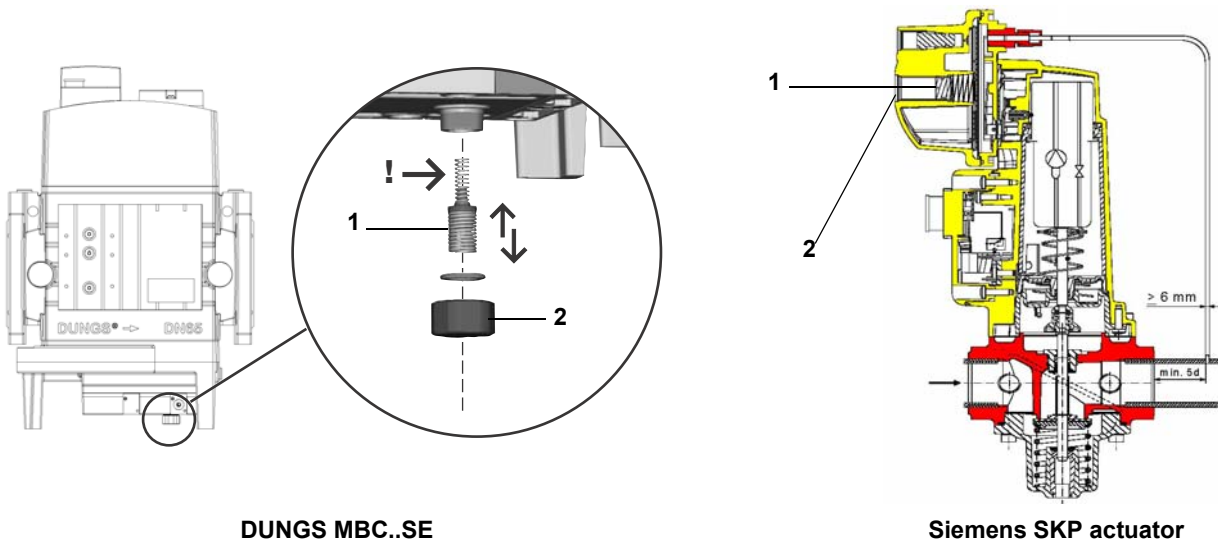

Fig. 21

Pressure adjusting range

The pressure adjusting range, downstream the gas valves group, changes according to the spring provided with the valve group.



Keys

- 1 spring
- 2 cap

DUNGS MBC valves:

Performance range (mbar)	4 - 20	20 - 40	40 - 80	80 - 150
Spring colour	-	red	black	green

Siemens VGD valves with SKP actuator :

Performance range (mbar)	0 - 22	15 - 120	100 - 250
Spring colour	neutral	yellow	red

Gas Proving System VPS504

The VPS504 checks the operation of the seal of the gas shut off valves. This check, carried out as soon as the boiler thermostat gives a start signal to the burner, creates, by means of the diaphragm pump inside it, a pressure in the test space of 20 mbar higher than the supply pressure. To install the DUNGS VPS504 gas proving system on the MD-DLE valves group, proceed as follows:

- 1 turn off gas supply.;
- 2 Switch off power supply.
- 3 remove the Multibloc screw plugs (Fig. 22-A);
- 4 insert sealing rings (10,5 x 2,25) into VPS 504 (Fig. 22-B - Fig. 23)
- 5 Torque screws 3, 4, 5, 6 (M4 x16) Fig. 23-C

Only use screws with metric thread on reassembly (modification, repair).

- 6 On completion of work, perform a leak and functional test.

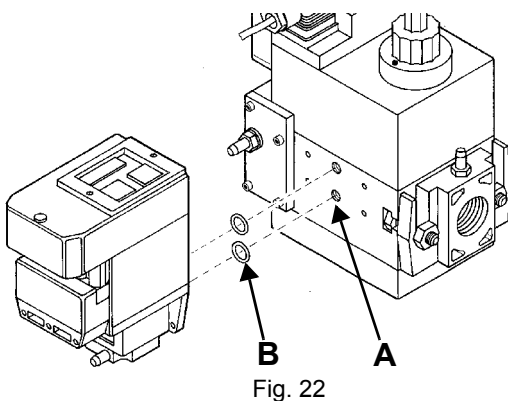

Fig. 22

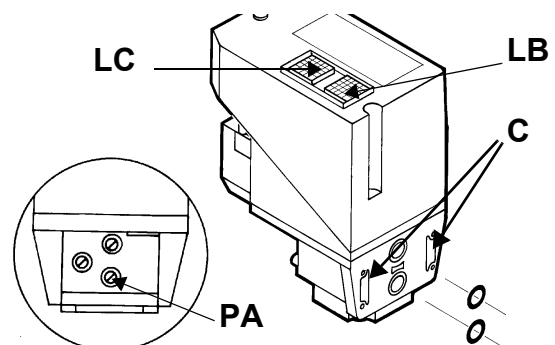

Fig. 23

When wishing to monitor the test, install a pressure gauge ranged to that of the pressure supply point PA (Fig. 23). If the test cycle is

satisfactory, after a few seconds the consent light **LC** (yellow) comes on. In the opposite case the lockout light **LB** (red) comes on. To restart it is necessary to reset the appliance by pressing the illuminated pushbutton **LB**.
Once the train is installed, connect the gas valves group and pressure switches plugs.



ATTENTION: once the gas train is mounted according to the diagrams shown in the previous pages, the gas proving test must be performed, according to the procedure set by the laws in force.

Electrical connections

	Respect the basic safety rules. make sure of the connection to the earthing system. do not reverse the phase and neutral connections. fit a differential thermal magnet switch adequate for connection to the mains.
	ATTENTION: before executing the electrical connections, pay attention to turn the plant's switch to OFF and be sure that the burner's main switch is in 0 position (OFF) too. Read carefully the chapter "WARNINGS", and the "Electrical connections" section.

	WARNING: The burner is provided with a jumper between terminals 6 and 7; in the event of connecting the high/low flame thermostat remove this jumper before connecting the thermostat.
	IMPORTANT: while connecting electric supply wires to burner's terminal block be sure that ground wire should be longer than phase and neutral ones.

	WARNING: if the cable that connects the thermostats and the control box should be longer than 3 meters, insert a sectioning relay following the attached electrical wiring diagram.
---	--

- Remove the cover of the burner electrical board.
- Execute the electrical connections to the supply terminal board as shown in figure, check the direction of the fan motor (see related paragraph) and refit the panel cover.

Wiring diagram keys on page 46.

Note on electrical supply

If the power supply to the burner is 230V three-phase or 230V phase-phase (without a neutral), with the Siemens LME2... control box, between the terminal 2 on the board and the earth terminal, an RC Siemens RC466890660 filter must be inserted.

Key

Fig. 24

C - Capacitor (22nF/250V)

LME - Siemens control box

R - Resistor (1Mohm)

RC466890660 - RC Siemens filter

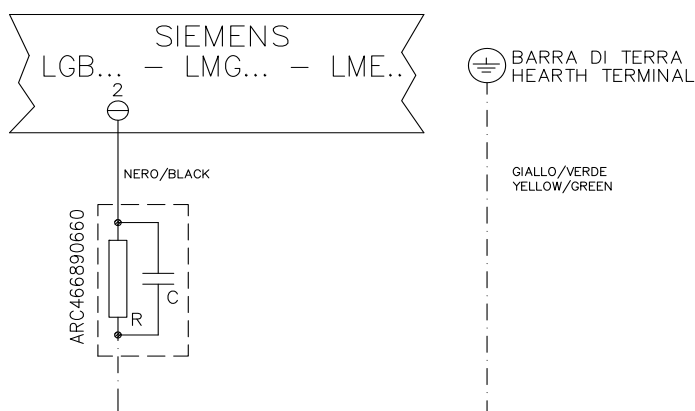

Rotation of fan motor
Once the electrical connection of the burner is executed, remember to check the rotation of the fan motor. The motor should rotate according to the "arrow" symbol on the body. In the event of wrong rotation, reverse the three-phase supply and check again the rotation of the motor.

	CAUTION: check the motor thermal cut-out adjustment
---	--

NOTE: the burners are supplied for three-phase 400V supply, and in the case of three-phase 230V supply it is necessary to modify the electrical connections into the terminal box of the electric motor and replace the overload tripped relay.

ADJUSTMENTS

Combustion head gas pressure curves depending on the flow rate

Curves are referred to pressure = 0mbar in the combustion head!

The curves referred to the gas pressure in the combustion head, depending on the gas flow rate, are referred to the burner properly adjusted (percentage of residual O₂ in the flues as shown in the "Recommended combustion values" table and CO in the standard limits). During this stage, the combustion head, the gas butterfly valve and the actuator are at the maximum opening. Refer to Fig. 25, showing the correct way to measure the gas pressure, considering the values of pressure in combustion chamber, surveyed by means of the pressure gauge or taken from the boiler's Technical specifications.

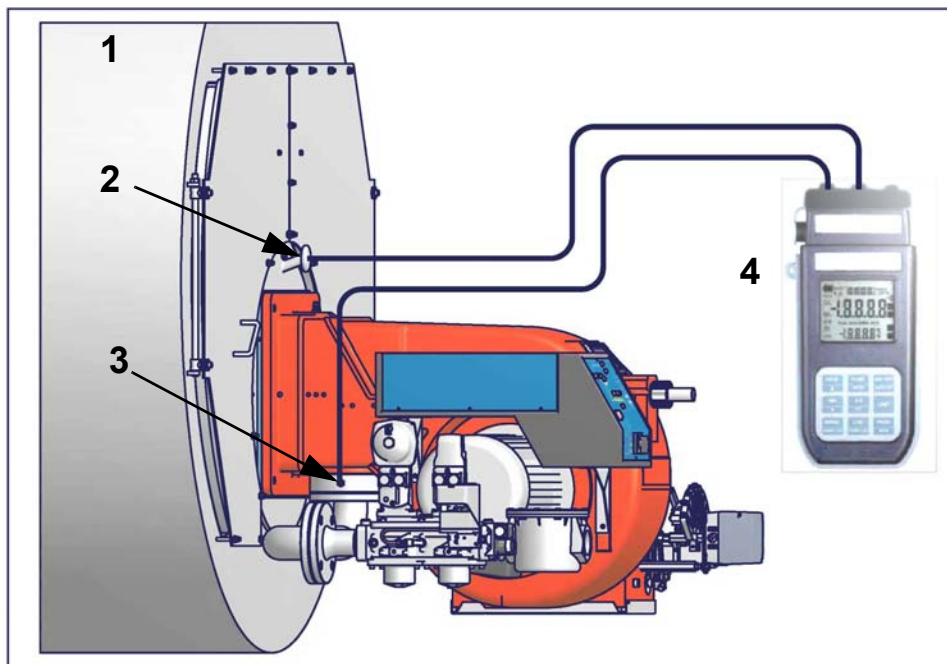

Fig. 25

Key

- 1 Generator
- 2 Pressure outlet on the combustion chamber
- 3 Gas pressure outlet on the butterfly valve
- 4 Differential pressure gauge

Measuring the gas pressure in the combustion head

In order to measure the pressure in the combustion head, insert the pressure gauge probes: one into the combustion chamber's pressure outlet to get the pressure in the combustion chamber and the other one into the butterfly valve's pressure outlet of the burner. On the basis of the measured differential pressure, it is possible to get the maximum flow rate: in the pressure - rate curves (showed on the next paragraph), it is easy to find out the burner's output in Stm³/h (quoted on the x axis) from the pressure measured in the combustion head (quoted on the y axis). The data obtained must be considered when adjusting the gas flow rate.

NOTE: THE PRESSURE-RATE CURVES ARE GIVEN AS INFORMATION ONLY; FOR A PROPER SETTING OF THE GAS RATE, PLEASE REFER TO THE GAS METER READING.

Gas pressure in combustion head vs. gas flow rate curves

P61

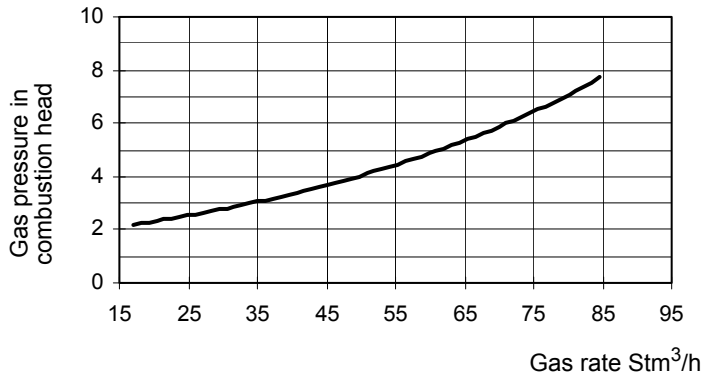

P65

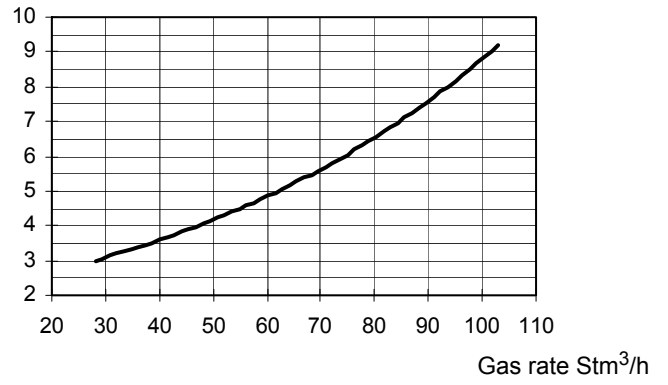

P71 M-...0.xx

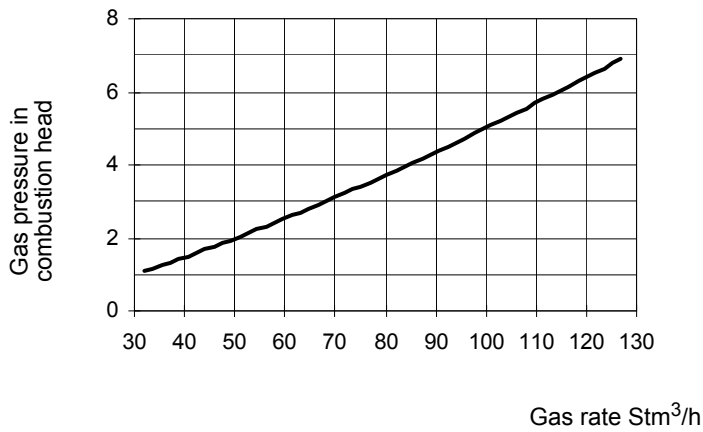

P71 M-...1.xx

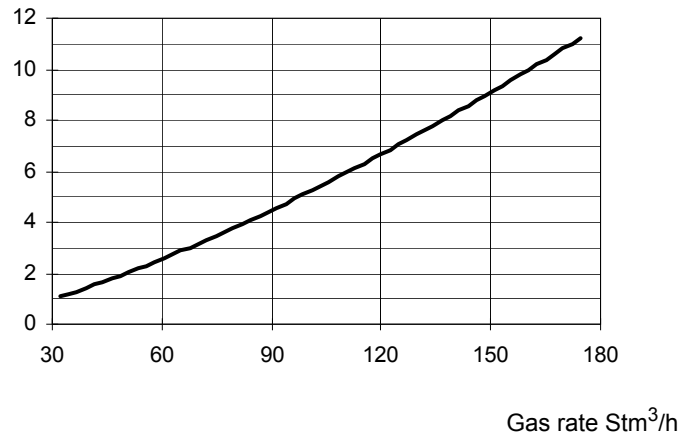

R73A M-...1.xx

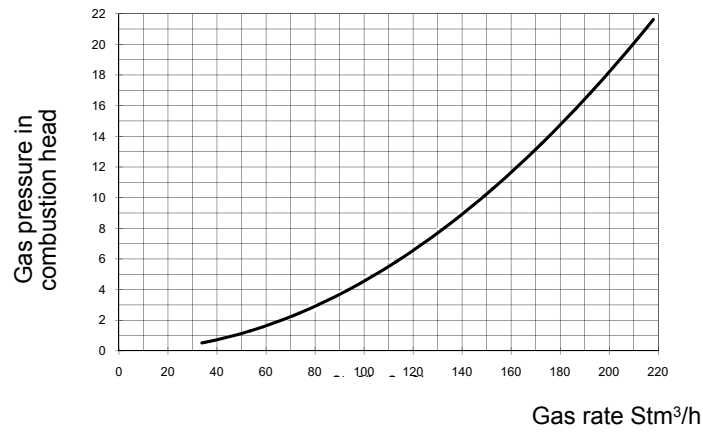

Adjusting air and gas flow rates

	ATTENTION: before starting the burner up, be sure that the manual cutoff valves are open and check that the pressure upstream the gas train complies the value quoted on paragraph "Technical specifications". Be sure that the mains switch is closed.
	ATTENTION: During commissioning operations, do not let the burner operate with insufficient air flow (danger of formation of carbon monoxide); if this should happen, make the fuel decrease slowly until the normal combustion values are achieved.
	WARNING: NEVER LOOSE THE SEALED SCREWS! OTHERWISE, THE DEVICE WARRANTY WILL BE INVALIDATE!

VPS504 Gas proving system

The VPS504 check the operation of the seal of the gas shut off valves. This check is carried out as soon as the boiler thermostat gives a start signal to the burner, creating, by means of the diaphragm pump inside it, a pressure in the test space of 20 mbar higher than the supply pressure.

When wishing to monitor the test, install a pressure gauge ranged to that of the pressure supply point PA.

If the test cycle is satisfactory, after a few seconds the consent light LC (yellow) comes on. In the opposite case the lockout light LB (red) comes on.

To restart it is necessary to reset the appliance by pressing the illuminated pushbutton LB

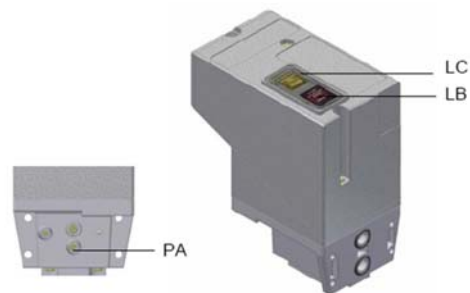

Startup Output

The start-up heat output shall not exceed 1/3 the operating maximum output. The minimum gas flow rate must be set in order to reach an output value lower than 1/3 the nominal output.

	IMPORTANT! the combustion air excess must be adjusted according to the in the following chart:
---	---

Recommended combustion parameters		
Fuel	Recommended (%) CO ₂	Recommended (%) O ₂
Natural gas	9 ÷ 10	3 ÷ 4.8

Adjustments - brief description

- Adjust the air and gas flow rates at the maximum output ("high flame") first, by means of the air damper and the valves group pressure stabiliser respectively.
- Check that the combustion parameters are in the suggested limits.
- Check the flow rate measuring it on the counter or, if it was not possible, verifying the combustion head pressure by means of a differential pressure gauge, as described on par. "Measuring the gas pressure in the combustion head" on page 22.
- Then, adjust the combustion values corresponding to the points between maximum and minimum (progressive -fully modulating burners only): set the shape of the adjusting cam foil. The adjusting cam sets the air/gas ratio in those points, regulating the opening-closing of the air damper.
- .Set, now, the low flame output, acting on the low flame microswitch of the actuator in order to avoid the low flame output increasing too much or that the flues temperature gets too low to cause condensation in the chimney.

To change the burner setting during the testing in the plant, follows the next procedure, according to the model provided.

Adjusting procedure

The burner is factory-set with the combustion head at the position that refers to the "MAX" output. The maximum output setting refers to the "fully-ahead" position of the combustion head. As for "fully-ahead" position, it means that the head is towards the boiler, "fully-backward" position means that the head is towards the operator. As far as the reduced output operation, progressively move the combustion head towards the "MIN" position, rotating clockwise the VRT screw (see picture below). The ID index shows how much the combustion head moved. **P61 - P65 - P71**

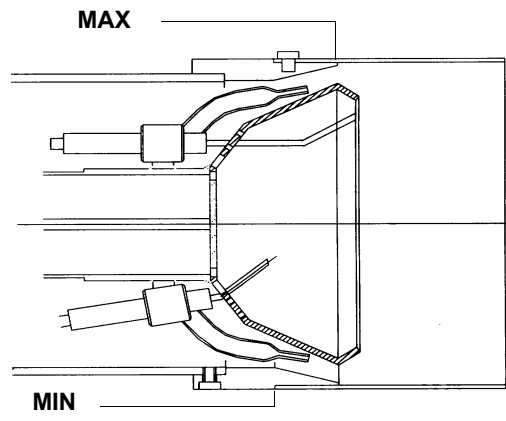
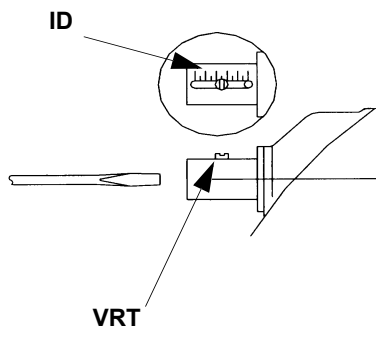



CAUTION: perform these adjustments once the burner is turned off and cooled.

The burner is factory-set with the adjusting plate holes fully open, and the combustion head at its MAX position, so it is fit to work at the maximum output.

To adjust the gas flow, partially close the holes, as follows:

- 1 loosen the three **V** screws that fix the adjusting plate **D**;
- 2 insert a screwdriver on the adjusting plate notches and let it move CW/CCW as to open/close the holes;
- 3 once the adjustment is performed, fasten the **V** screws.

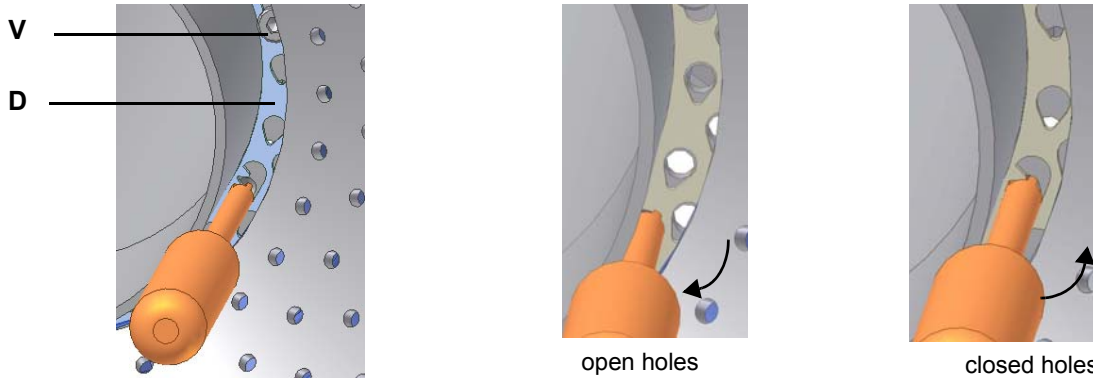

To let the burner operate at a lower output, loose the **VB** screw and move progressively back the combustion head towards the MIN position, by turning clockwise the **VRT** ring nut. Fasten **VB** screw when the adjustment is accomplished.



Attention! Change the combustion head position only if necessary. If so, repeat the air and gas adjustments described above.

DUNGS MB-DLE gas valves group: Before starting the burner up, adjust the valves group slow opening: to set the slow opening remove cover **T**, reverse it upside down and use it as a tool to rotate screw **VR**. Decrease the ignition flow rate by screwing, increase it by unscrewing. Do not use a screwdriver on the screw **VR**!

Note: the screw **VSB** must be removed only in case of replacement of the coil (see picture on page 24).

On the **DUNGS MBC..SE gas valves group**, set the pressure regulator to 1/3 of its stroke, using a 2.5 allen key.

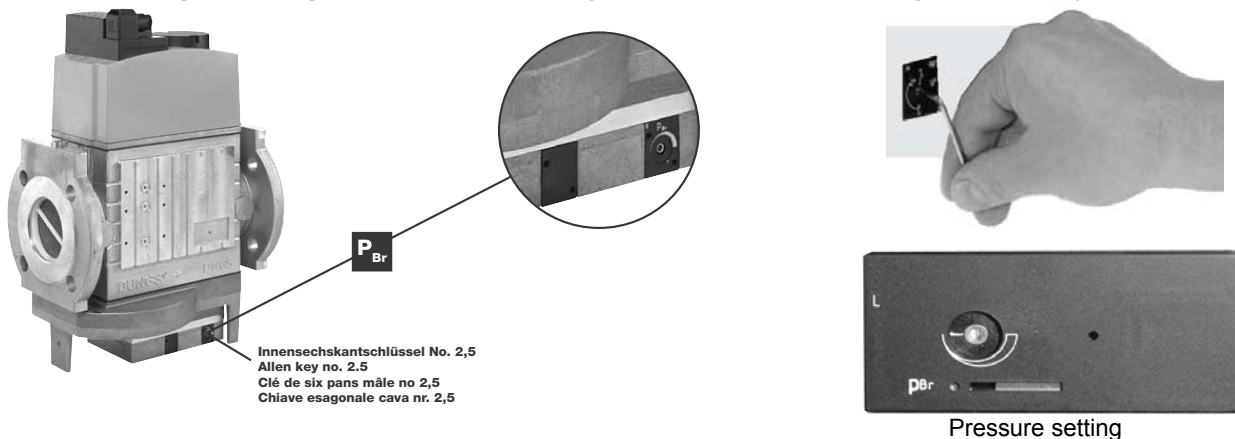

- 1 Turn the burner on by means of its main switch **A**: if the burner locks (LED **B** on in the control panel) press the RESET button (**C**) on the control panel (Fig. 27). See chapter "Operation" for further details.
- 2 check the fan motor rotation (see "RC466890660 - RC Siemens filterRotation of fan motor" on page 21)
- 3 Start the burner up by means of the thermostat series and wait until the pre-purge phase comes to end and that burner starts up;
- 4 the burner starts up in the low flame stage: drive the burner to high flame stage, by means of the "high/low flame" thermostat **TAB**.
- 5 adjust the burner combustion values in the high flame stage as described in the following steps.
- 6 go on adjusting air and gas flow rates: check, continuously, the flue gas analysis, as to avoid combustion with little air; dose the air according to the gas flow rate change following the steps quoted below;
- 7 acting on the pressure governor of the valves group, adjust the **gas flow rate in the high flame stage** as to meet the values requested by the boiler/utilisation:
 - **Multibloc MB-DLE:** the valve is adjusted by means of the **RP** regulator after slackening the locking screw **VB** by a number of

turns. By unscrewing the regulator **RP** the valve opens, screwing the valve closes. The pressure stabilizer is adjusted by operating the screw **VS** located under the cover **C**. By screwing down the pressure is increased and by unscrewing it is reduced. **Note:** the screw **VSB** must be removed only in case of replacement of the coil.

- **Siemens VGD valves group:** remove cap **T** and act on the **VR** adjusting screw to increase or decrease the pressure and consequently the gas rate; screwing **VR** the rate increases, unscrewing it decreases (see next figure).

- **Dungs MBC..SE valves group:** act on its pressure governor to increase or decrease the pressure and consequently the gas rate.

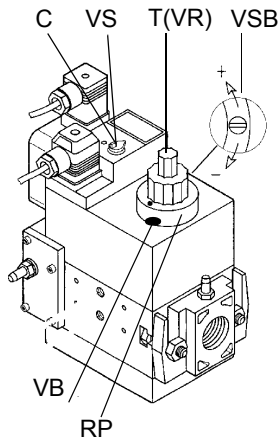

Dungs Multibloc MB-DLE

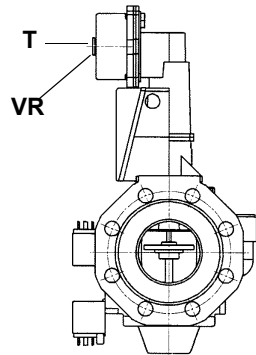

Siemens VGD..

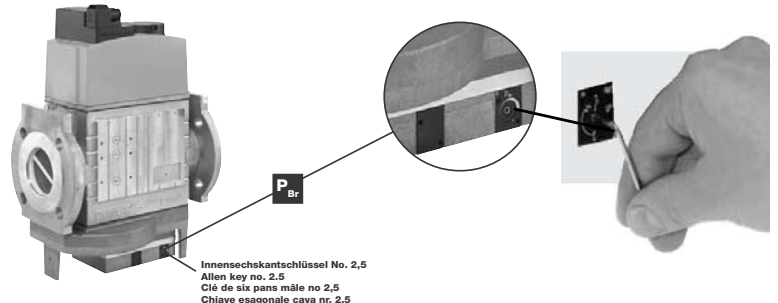

Dungs MBC..SE

⚠ Pressure governor is factory-set. The setting values must be locally adapted to machine conditions. Important! Follow the instructions carefully!

8 .To adjust the **air flow rate in the high flame stage**, loose the **RA** nut and screw **VRA** as to get the desired air flow rate: moving the rod **T** towards the air damper shaft, the air damper opens and consequently the air flow rate increases, moving it far from the shaft the air damper closes and the air flow rate decreases.

Note: once the procedure is performed, be sure that the blocking nut **RA** is fasten.

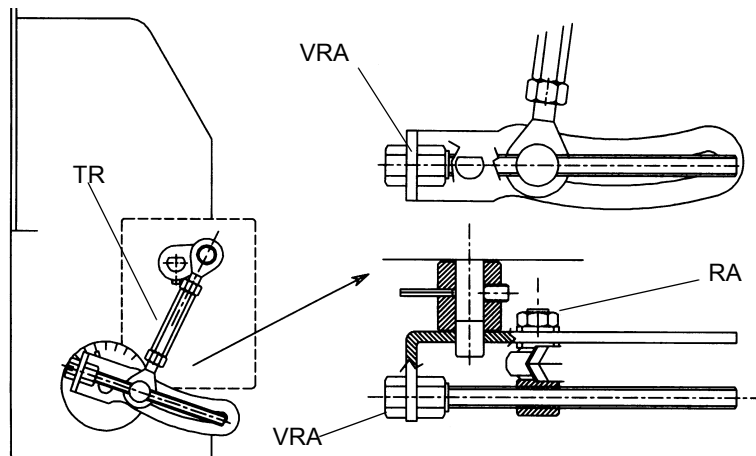

Go on adjusting the burner according to the model (double-stage, progressive, fully-modulating).

Double-stage burners

- 9 drive the burner to the low flame stage by means of the **TAB** thermostat;
- 10 In order to change the gas flow rate slacken the nuts **DB** (Fig. 26) and adjust the opening angle of the gas butterfly valve by rotating the rod **TG** (clockwise rotation increases gas flow, anticlockwise rotation decreases it). The slot on the butterfly valve shaft shows the opening degree of the valve regarding the horizontal axis (Fig. 26).

NOTE: At the end of settings, make sure the locking screws **RA** and **DB** are fully tightened.

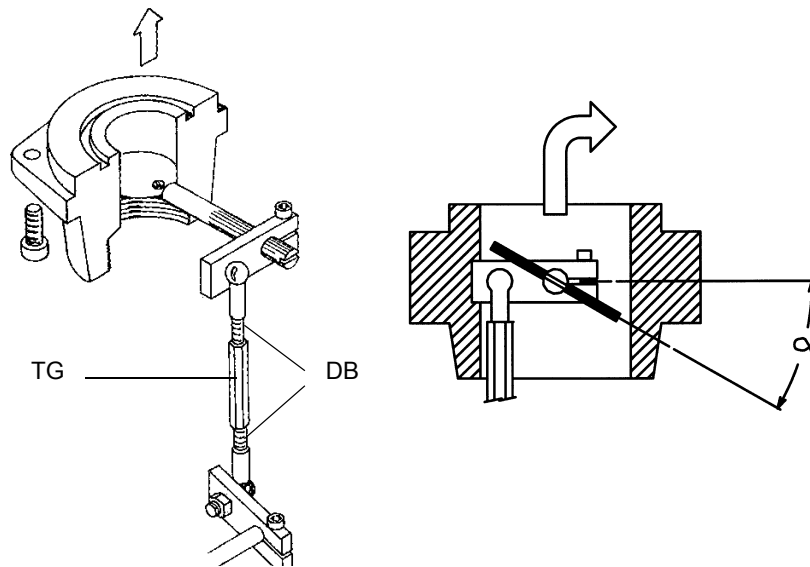
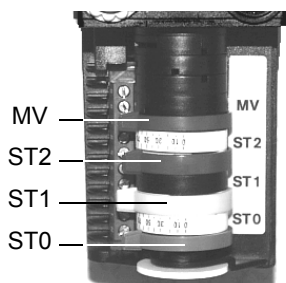

Fig. 26

- 11 Now adjust the pressure switches (see page 30).
- 12 If it is necessary to change the burner output in the low flame stage, move the low flame cam: the low flame position matches the ignition position. As far as burners fitted with Dungs MBC gas valves, the low flame cam does not match the ignition cam position, that is why it must be set at about 30° more than the ignition cam.
- 13 Turn the burner off and then start it up again. If the adjustment is not correct, repeat the previous steps.

Berger STA6 B 3.41 (high-low flame burners)

Siemens SQN72.2A4Ax (high-low flame burners)



For DUNGS MB-DLE / Siemens VGD gas valves	Actuator camsBerger STA	Siemens SQN72
High flame position (set to 90°)	ST2	I (red)
Low flame and ignition position	ST1	III (orange)
Stand-by position (set to 0°)	ST0	II (blue)
Not used	MV	IV (black)

For DUNGS MBCgas valves	Actuator camsBerger STA	Siemens SQN72
High flame position (set to 90°)	ST2	I (red)
Stand-by position (set to 0°)	ST0	III (orange)
Ignition	ST1	II (blue)
Low flame position	MV	IV (black)

- Berger STA: on this actuator, the manual control of the air damper is not provided; the setting of the cams is carried out working with a screwdriver on the **VS** screw placed on the cam.

Berger STA12: a key is provided to move the cams.

Siemens SQN72: a key is provided to move cams I and IV, the other cams can be moved by means of screws.

On the BERGER STA12B3.41 actuator, the manual air damper control is not provided. On the Siemens actuator the AUTO/MAN mode is provided (see picture).

Progressive burners

Once the procedure till step 8 described on paragraph "Adjusting procedure" on page 24, is accomplished, go on as follows:

9 set the low flame cam matching the high flame cam;

10 set the **TAB** thermostat to the minimum in order that the actuator moves progressively towards the low flame position;

The manual air damper control is not provided on these actuators. The adjustments must be carried out acting manually on the cams.

Berger STA12B3.41 (progressive and fully modulating burners)

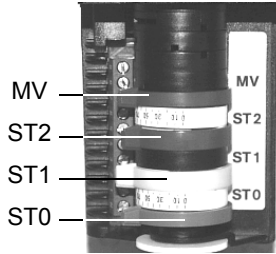

Siemens SQN72.2A4Ax (progressive and fully modulating burners)



For DUNGS MB-DLE / Siemens VGD gas valves	Actuator camsBerger STA	Siemens SQN72
High flame position (set to 90°)	ST2	I (red)
Low flame and ignition position	ST1	III (orange)
Stand-by position (set to 0°)	ST0	II (blue)
Not used	MV	IV (black)

For DUNGS MBCgas valves	Actuator camsBerger STA	Siemens SQN72
High flame position (set to 90°)	ST2	I (red)
Stand-by position (set to 0°)	ST0	III (orange)
Ignition	ST1	II (blue)
Low flame position	MV	IV (black)

11 move the low flame cam to the minimum to move the actuator towards the low flame until the two bearings find the adjusting screw that refers to the lower position: screw **V** to increase the rate, unscrew to decrease.

12 Move again the low flame cam towards the minimum to meet the next screw on the adjusting cam and repeat the previous step; go on this way as to reach the desired low flame point.

13 Now adjust the pressure switches (see page 30).

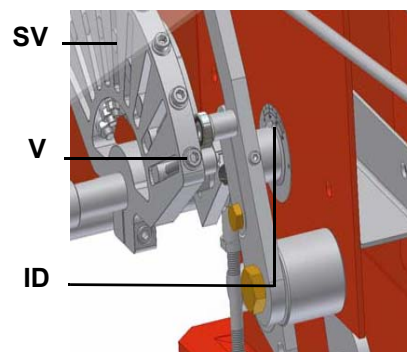
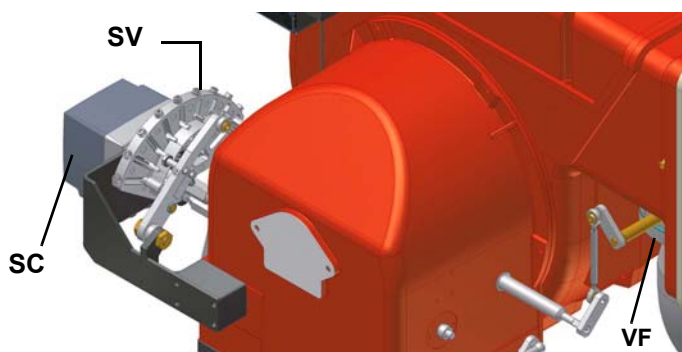

14 If it is necessary to change the burner output in the low flame stage, move the low flame cam: the low flame position matches the ignition position. As far as burners fitted with Dungs MBC gas valves, the low flame cam does not match the ignition cam position, that is why it must be set at about 30° more than the ignition cam.

15 Turn the burner off and then start it up again. If the adjustment is not correct, repeat the previous steps.

Fully modulating burners

Calibration of air and gas pressure switches

The **air pressure switch** locks the control box if the air pressure is not the one requested. If it happens, unlock the burner by means of the control box unlock pushbutton, placed on the burner control panel.

The **gas pressure switches** check the pressure to avoid the burner operate when the pressure value is not in the requested pressure range.

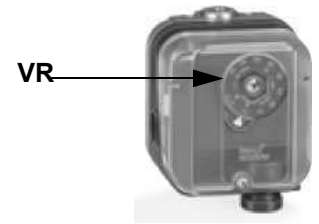

Calibration of air pressure switch

To calibrate the air pressure switch, proceed as follows:

- Remove the transparent plastic cap.
- Once air and gas setting have been accomplished, startup the burner.
- During the pre-purge phase of the operation, turn slowly the adjusting ring nut **VR** in the clockwise direction until the burner lockout, then read the value on the pressure switch scale and set it to a value reduced by 15%.
- Repeat the ignition cycle of the burner and check it runs properly.
- Refit the transparent plastic cover on the pressure switch.

Calibration of low gas pressure switch

As for the gas pressure switch calibration, proceed as follows:

- Be sure that the filter is clean.
- Remove the transparent plastic cap.
- While the burner is operating at the maximum output, test the gas pressure on the pressure port of the minimum gas pressure switch.
- Slowly close the manual cutoff valve (placed upstream the pressure switch, see gas train installation diagram), until the detected pressure is reduced by 50%. Pay attention that the CO value in the flue gas does not increase: if the CO values are higher than the limits laid down by law, slowly open the cutoff valve as to get values lower than these limits.
- Check that the burner is operating correctly.
- Clockwise turn the pressure switch adjusting ring nut (as to increase the pressure value) until the burner stops.
- Slowly fully open the manual cutoff valve.
- Refit the transparent plastic cover on the pressure switch.

Adjusting the maximum gas pressure switch (when provided)

To calibrate the maximum pressure switch, proceed as follows according to its mounting position:

- 1 remove the pressure switch plastic cover;
- 2 if the maximum pressure switch is mounted upstream the gas valves: measure the gas pressure in the network, when flame is off; by means of the adjusting ring nut **VR**, set the value read, increased by the 30%.
- 3 if the maximum pressure switch is mounted downstream the "gas governor-gas valves" group and upstream the butterfly valve: light the burner, adjust it according to the procedure in the previous paragraph. Then, measure the gas pressure at the operating flow rate, downstream the "gas governor-gas valves" group and upstream the butterfly valve; by means of the adjusting ring nut **VR**, set the value read on step 2, increased by the 30%;
- 4 replace the plastic cover.

PGCP Gas leakage pressure switch (with Siemens LDU burner control/Siemens LMV Burner Management System)

- remove the pressure switch plastic cover;
- adjust the PGCP pressure switch to the same value set for the minimum gas pressure switch;
- replace the plastic cover.

LIMITATIONS OF USE

THE BURNER IS AN APPLIANCE DESIGNED AND CONSTRUCTED TO OPERATE ONLY AFTER BEING CORRECTLY CONNECTED TO A HEAT GENERATOR (E.G. BOILER, HOT AIR GENERATOR, FURNACE, ETC.), ANY OTHER USE IS TO BE CONSIDERED IMPROPER AND THEREFORE DANGEROUS.

THE USER MUST GUARANTEE THE CORRECT FITTING OF THE APPLIANCE, ENTRUSTING THE INSTALLATION OF IT TO QUALIFIED PERSONNEL AND HAVING THE FIRST COMMISSIONING OF IT CARRIED OUT BY A SERVICE CENTRE AUTHORIZED BY THE COMPANY MANUFACTURING THE BURNER.

A FUNDAMENTAL FACTOR IN THIS RESPECT IS THE ELECTRICAL CONNECTION TO THE GENERATOR'S CONTROL AND SAFETY UNITS (CONTROL THERMOSTAT, SAFETY, ETC.) WHICH GUARANTEES CORRECT AND SAFE FUNCTIONING OF THE BURNER.

THEREFORE, ANY OPERATION OF THE APPLIANCE MUST BE PREVENTED WHICH DEPARTS FROM THE INSTALLATION OPERATIONS OR WHICH HAPPENS AFTER TOTAL OR PARTIAL TAMPERING WITH THESE (E.G. DISCONNECTION, EVEN PARTIAL, OF THE ELECTRICAL LEADS, OPENING THE GENERATOR DOOR, DISMANTLING OF PART OF THE BURNER).

NEVER OPEN OR DISMANTLE ANY COMPONENT OF THE MACHINE.

OPERATE ONLY THE MAIN SWITCH, WHICH THROUGH ITS EASY ACCESSIBILITY AND RAPIDITY OF OPERATION ALSO FUNCTIONS AS AN EMERGENCY SWITCH, AND ON THE RESET BUTTON.

IN CASE OF A BURNER SHUT-DOWN, RESET THE CONTROL BOX BY MEANS OF THE RESET PUSHBUTTON. IF A SECOND SHUT-DOWN TAKES PLACE, CALL THE TECHNICAL SERVICE, WITHOUT TRYING TO RESET FURTHER.

WARNING: DURING NORMAL OPERATION THE PARTS OF THE BURNER NEAREST TO THE GENERATOR (COUPLING FLANGE) CAN BECOME VERY HOT, AVOID TOUCHING THEM SO AS NOT TO GET BURNT.

OPERATION



.ATTENTION: BEFORE STARTING THE BURNER UP, BE SURE THAT THE MANUAL CUTOFF VALVES ARE OPEN AND CHECK THAT THE PRESSURE VALUE UPSTREAM THE GAS TRAIN MATCHES THE VALUE ON PARAGRAPH "TECHNICAL SPECIFICATIONS"). CHECK THAT THE MAINS SWITCH IS CLOSED. CAREFULLY READ THE "WARNINGS" CHAPTER.

- Turn to the ON position the mains switch A on the burner front panel.
- Check the flame control box is not in the lockout position (light B on), if necessary reset it by means of the pushbutton C (reset);
- Check that the control thermostats or pressure switches enable the burner to operate.
- Check the gas supply pressure is sufficient (light D on), if necessary, adjust the pressure switches.

Only burners provided with the gas proving system: the check cycle of the gas proving system starts; the end of this check is signalled by the light of the lamp on the device. When the valves check is finished, the startup cycle of the burner begins. In the case of a leak in a valve, the gas proving system locks and the lamp E lights. To reset the device press the device pushbutton.

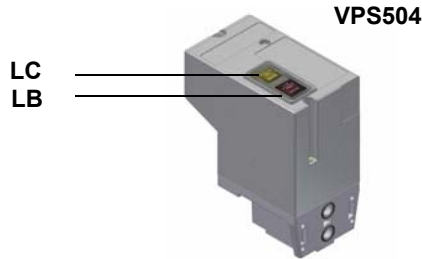

- The startup cycle begins, the actuator drives the air damper to the maximum opening position, the fan motor starts and the pre-purge phase begins. During the pre-purge phase, the complete opening of the air damper is signalled by the lamp F on the frontal panel of the electrical board.
- At the end of the pre-purge phase, the air damper goes to the ignition position, the ignition transformer turns on (signalled by the lamp H) and few seconds later the solenoid valves EV1 and EV2 are energized (lights I and L on the front panel).
- Few seconds after the opening of the valves, the ignition transformer turns off and the lamp H turns off subsequently:

Double-stage burners: the burner is on in low flame stage (light G is on); some seconds later, the high flame operation begins and the burner switches automatically to high flame (light F is on) or remains in low flame operation, according to the plant requests.

Progressive and fully modulating burners - few seconds after the gas valve opening, the ignition transformer is de-energized. The burner is in low flame operation and some seconds later, the two-stages operation begins; the burner increases or decreases its output, directly driven by the external thermostat (progressive version) or by the modulator (P in Fig. 27, fully modulating burners only).

Fig. 27 - Frontal panel on the electrical board

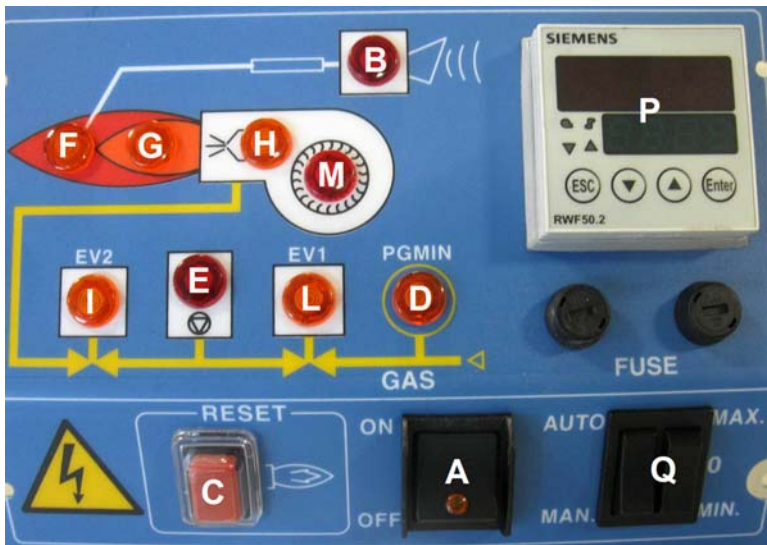

Keys

- A Main switch on-off
- B Lockout indicator light
- C Reset pushbutton for flame control box
- D Gas pressure switch consent indicator light
- E Gas proving system lockout indicator light (only on burners with gas proving system)
- F High flame operation indicator light (or air damper open during pre-purge phase)
- G Low flame operation indicator light
- H Ignition transformer operation indicator light
- I Valve in operation indicator light for EV2
- L Valve in operation indicator light for EV1
- M Indicator light for fan motor overload tripped (only three-phase burners); to reset the overload tripped, the electrical board must be opened).
- P Modulator (fitted only on fully modulating burners)
- Q Operation selector MAN - AUTO (operation in manual or automatic mode):
 - MIN = operation with minimum output
 - 0 = Stop
 - MAX = operation at the maximum output

At least once a year carry out the maintenance operations listed below. In the case of seasonal servicing, it is recommended to carry out the maintenance at the end of each heating season; in the case of continuous operation the maintenance is carried out every 6 months.



WARNING: ALL OPERATIONS ON THE BURNER MUST BE CARRIED OUT WITH THE MAINS DISCONNECTED AND THE FUEL MANUAL CUTOFF VALVES CLOSED!

ATTENTION: READ CAREFULLY THE "WARNINGS" CHAPTER AT THE BEGINNING OF THIS MANUAL..

ROUTINE MAINTENANCE

- Clean and examine the gas filter cartridge, if necessary replace it (see next paragraphs).
- Remove, check and clean the combustion head (see Fig. 35)
- Check the ignition electrode, clean, adjust and, if necessary, replace (see page 38)
- Check the detection electrode, clean, adjust and, if necessary, replace; in case of doubt, check the detection circuit following the diagram in Fig. 41 and Fig. 42, after turning the burner back into operation.
- Clean and grease leverages and rotating parts.



ATTENTION: when servicing, if it was necessary to disassemble the gas train parts, remember to execute the gas proving test, once the gas train is reassembled, according to the procedure imposed by the law in force.

Removing the filter in the MULTIBLOC DUNGS MB-DLE 405..412

- Check the filter at least once a year!
- Change the filter if the pressure difference between pressure connection 1 and 3 (Fig. 28-Fig. 29) is $\Delta p > 10$ mbar.
- Change the filter if the pressure difference between pressure connection 1 and 3 (Fig. 28-Fig. 29) is twice as high compared to the last check.

You can change the filter without removing the fitting.

- 1 Interrupt the gas supply closing the on-off valve.
- 2 Remove screws 1 ÷ 4 using the Allen key n. 3 and remove filter cover 5 in Fig. 30.
- 3 Remove the filter 6 and replace with a new one.
- 4 Replace filter cover 5 and tighten screws 1 ÷ 4 without using any force and fasten.
- 5 Perform leakage and functional test, $p_{max.} = 360$ mbar.
- 6 Pay attention that dirt does not fall inside the valve.

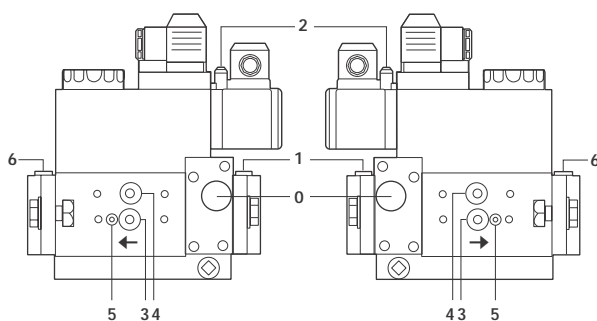

Fig. 28

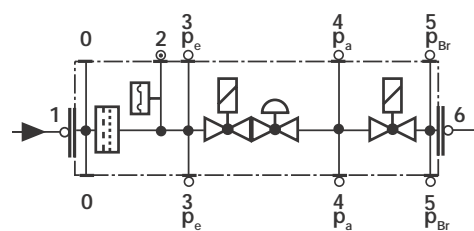

Fig. 29

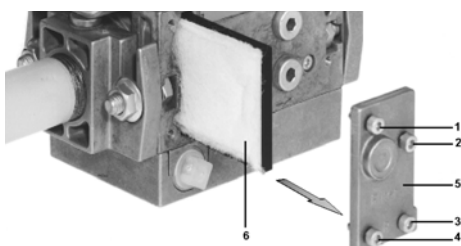

Fig. 30

Removing the filter in the MULTIBLOC DUNGS MB-DLE 415 - 420 B01 1" 1/2 - 2"

- Check the filter at least once a year!
- Change the filter if the pressure difference between pressure connection 1 and 2 (Fig. 31-Fig. 32) $\Delta p > 10$ mbar.
- Change the filter if the pressure difference between pressure connection 1 and 2 (Fig. 31-Fig. 32) is twice as high compared to the last check.

You can change the filter without removing the fitting.

- 1 Interrupt the gas supply closing the on-off valve.
- 2 Remove screws 1 ÷ 6 (Fig. 33).
- 3 Change filter insert.
- 4 Re-insert filter housing, screw in screws 1 ÷ 6 without using any force and fasten.
- 5 Perform leakage and functional test, $p_{max.} = 360$ mbar.
- 6 Pay attention that dirt does not fall inside the valve.

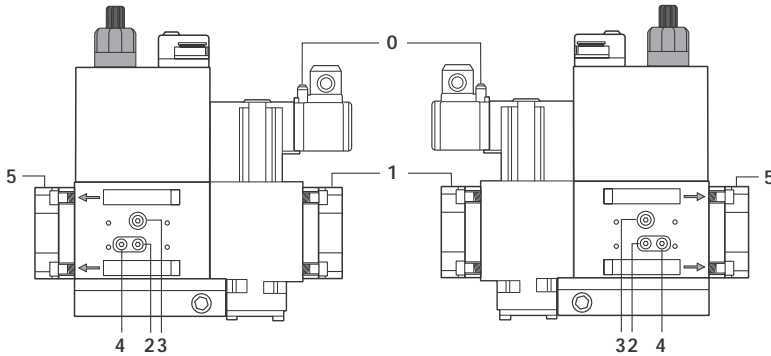

Fig. 31

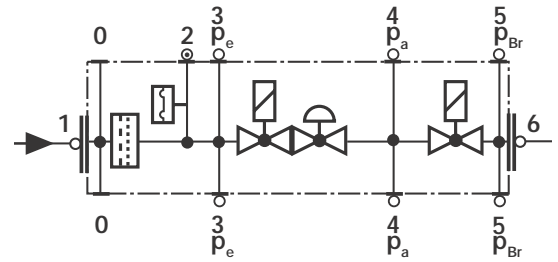

Fig. 32

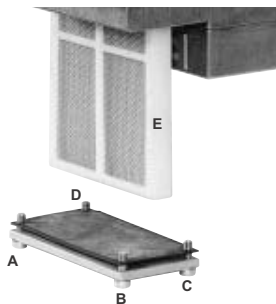

Fig. 33

Inspection and replacement of the MULTIBLOC DUNGS MBC..SE filter (Threaded valves group)

Inspect the filter at least once a year.

- Change the filter, if pressure value between pressure connections 1 and 2 is greater than 10 mbar.
- Change the filter, if pressure value between pressure connections 1 and 2 is twice as high compared to the last inspection.

1. Interrupt gas supply: close ball valve
 2. Remove screws 1-2
 3. Replace the filter insert 3
 4. Screw in screws 1-2 without use force to fasten.
 5. Perform leakage and function test.
 6. Pay attention that dirt does not fall inside the valve.
- Space requirements for fitting filter, A: from 150 to 230 mm.

Fig.34

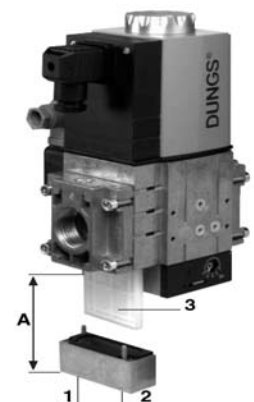

Gas filter maintenance



ATTENTION: Before opening the filter, close the manual cutoff valve downstream the filter and bleed the gas; check that inside the filter there is no pressurised gas.

To clean or remove the filter, proceed as follows:

- 1 remove the cap unscrewing the fixing screws (A);
- 2 remove the filtering cartridge (B), clean it using water and soap, blow it with compressed air(or replace it, if necessary)
- 3 replace the cartridge in its proper position taking care to place it inbetween the guides as not to hamper the cap replacement;
- 4 be sure to replace the "O" ring into its place (C) and replace the cover fastening by the proper screws (A).

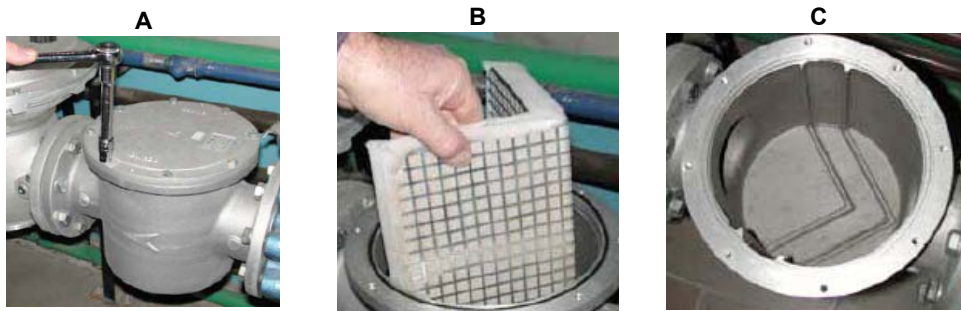

5

To replace the spring in the gas valve group, proceed as follows:

1. Carefully twist the protection cap 1 and the O-ring 2.
2. Remove the "set value" spring 3 from housing 4.
3. Replace spring 3.
4. Carefully insert the new "set value" spring. Pay attention to mount properly. First insert the spring part with smaller diameter in the housing.
5. Place O-ring 2 in protective cap 1. Screw in the protective cap with the O-ring in it.
6. Stick the adhesive label for spring identification on the type plate.

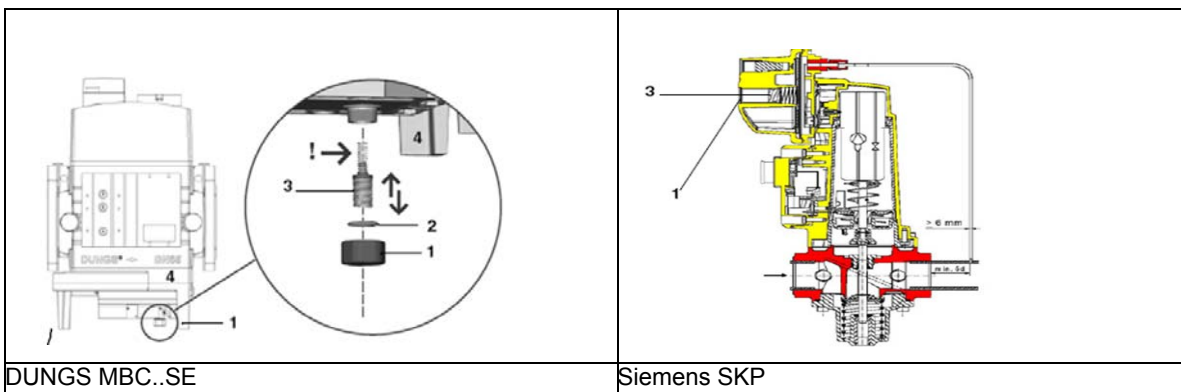

Removing the combustion head

Type P61

- Remove cover C.
- Unscrew the two screws S holding in position the washer and then unscrew VRT to free the threaded rod AR.
- Unscrew the screws V holding in position the manifold G and pull out the complete group as shown in figure.

Note: for the subsequent assembly carry out the above described operations in the reverse order, checking the correct position of the OR ring.

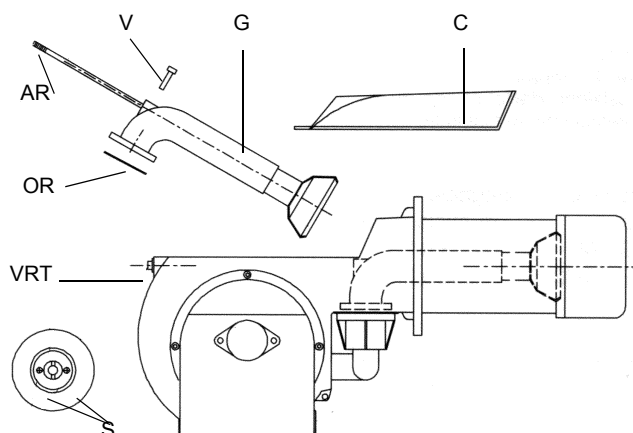

Fig. 35

Type P65 / P71 / R73A

- Remove the lid C.
- Unscrew the screws V holding in position the manifold G and pull out the complete group as shown in figure.

Note: for the subsequent assembly carry out the above described operations in the reverse order, checking the correct position of the OR ring.

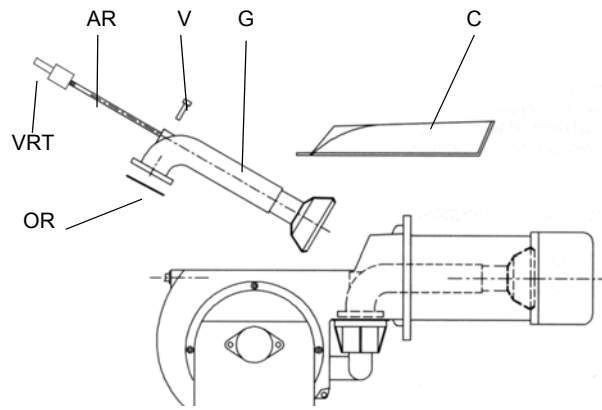

Fig. 36

To remove the combustion head, pull it out. Once removed, check that the air and gas holes are not obstructed. Clean the combustion head by means of compressed air or scrape off the scale using a metallic brush.

Adjusting the electrodes

Important Note: Check the ignition and detection electrodes after removing/adjusting the combustion head.

	<p>ATTENTION: avoid the ignition and detection electrodes to contact metallic parts (blast tube, head, etc.), otherwise the boiler operation would be compromised. Check the electrodes position after any intervention on the combustion head.</p>
--	--

- Electrodes position settings (P61 / P65 / P71)

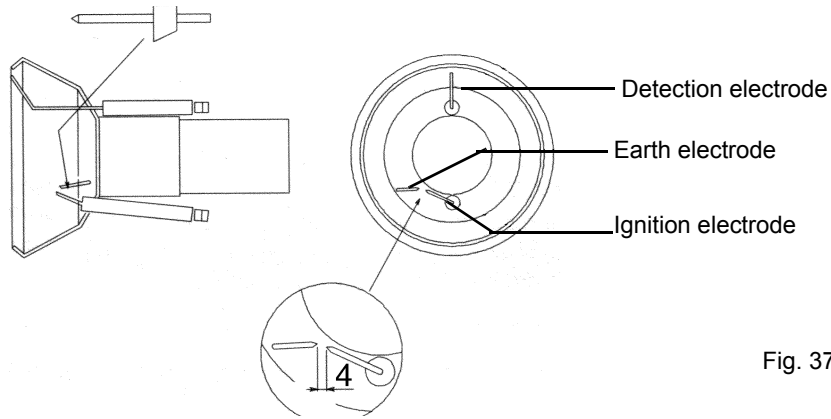

Fig. 37

Electrodes position settings - R73A

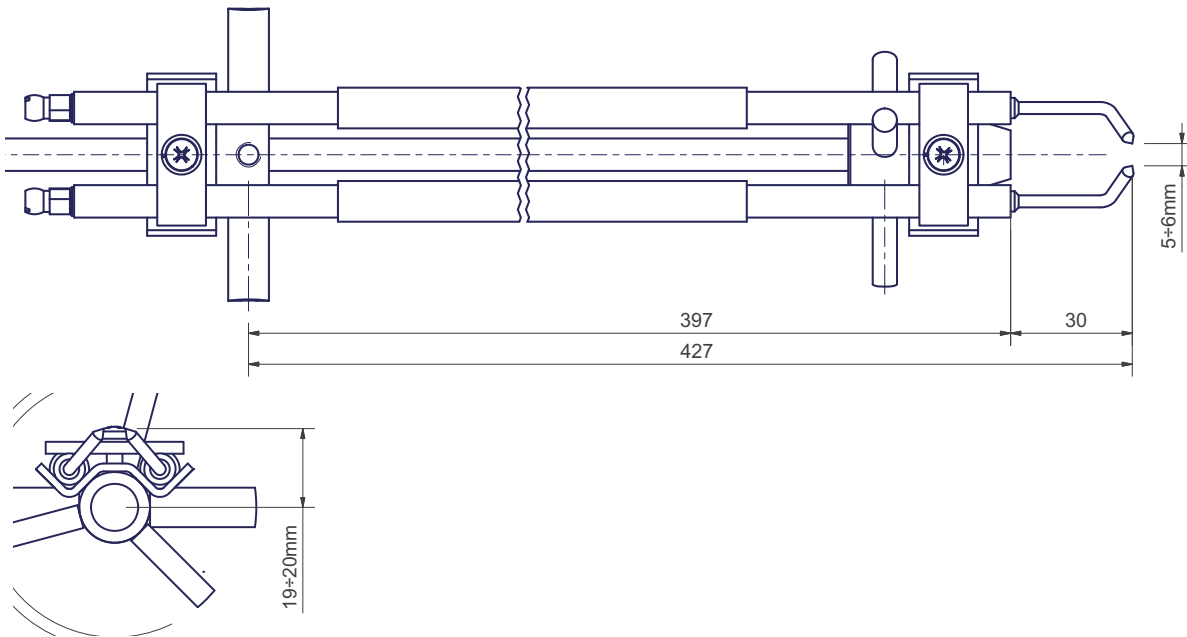

Fig. 38

Replacing the electrodes



ATTENTION: avoid the ignition and detection electrodes to contact metallic parts (blast tube, head, etc.), otherwise the boiler's operation would be compromised. Check the electrodes position after any intervention on the combustion head.

P61 / P65 / P71

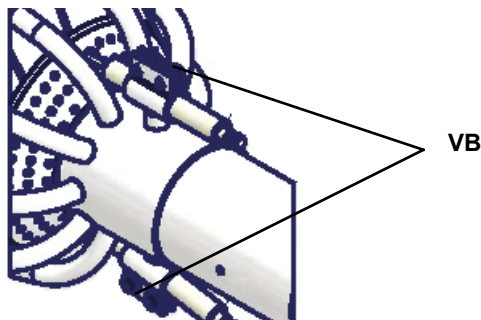

Fig. 39

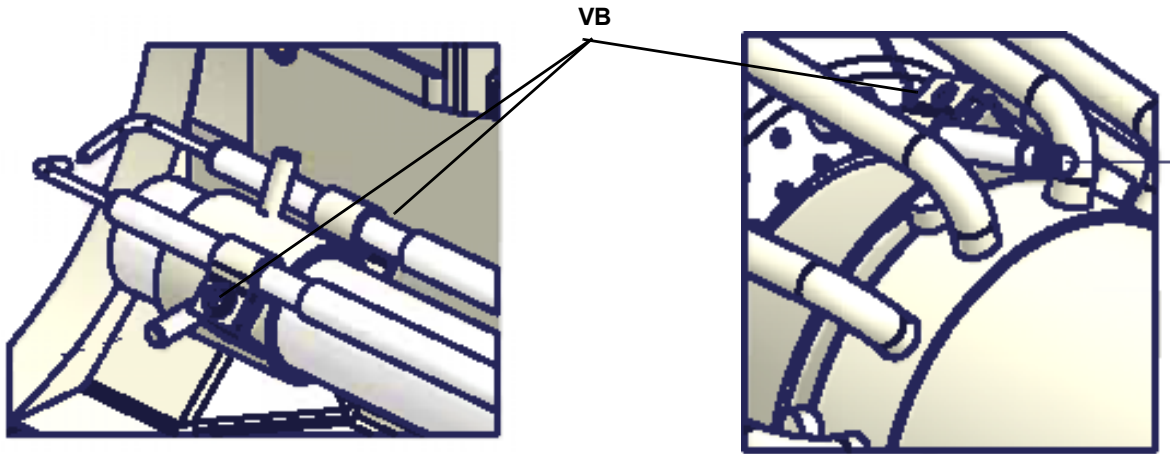

Fig. 40

Checking the detection current

To measure the detection signals refer to the diagrams in Fig. 41 and Fig. 42. If the signal is less than the indicated value, check the position of the detection electrode, the electrical contacts and if necessary replace the detection electrode.

Control box	Minimum detection signal
Siemens LME21-22	3 μ A

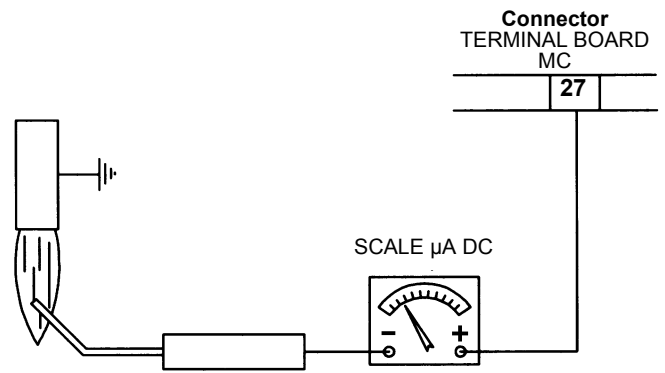

Fig. 41

Test point on burners fitted with printed circuit

To check the detection current, remove the jumper between terminals and connect the microammeter (see Fig. 42).

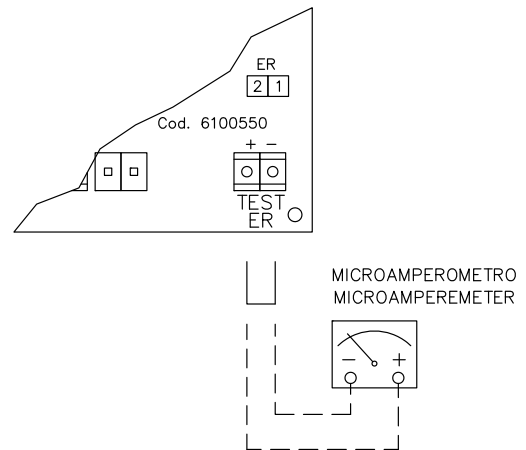

Fig. 42

Seasonal stop

To stop the burner in the seasonal stop, proceed as follows:

- 1 turn the burner main switch to 0 (Off position)
- 2 disconnect the power mains
- 3 close the fuel valve of the supply line

Burner disposal

In case of disposal, follow the instructions according to the laws in force in your country about the "Disposal of materials".

TROUBLESHOOTING

CAUSE	TROUBLE											
	THE BURNER DOESN'T START	CONTINUE WITH PRE-PURGE	DOESN'T START AND LOCK-OUT	DOESN'T START AND REPEATS THE CYCLE	STARTS AND REPEATS THE CYCLE	STARTS AND LOCK-OUT	THE FLAME MONITOR DEVICE DOESN'T GIVE CONSENT TO START	DOESN'T SWITCH TO HIGH FLAME	DOESN'T RETURN IN LOW FLAME	THE SERVO CONTROL IS LOCK AND VIBRATE	LOCK-OUT DURING OPERATION	TURNS OF AND REPEATS CYCLE DURING OPERATION
MAIN SWITCH OPEN	●											
LACK OF GAS	●			●								
MAXIMUM GAS PRESSURE SWITCH DEFECTIVE (IF PROVIDED)	●		●									
THERMOSTATS/PRESSURE SWITCHES DEFECTIVE	●			●								●
OVERLOAD TRIPPED INTERVENTION	●											
AUXILIARIES FUSE INTERRUPTED	●											
CONTROL BOX FAULTY	●	●	●			●					●	
DEFECTIVE SERVOCONTROL (IF PROVIDED)	●	●	●				♦					
AIR PRESSURE SWITCH FAULT OR BAD SETTING	●					●	●				●	
MINIMUM GAS PRESSURE SWITCH DEFECTIVE OR GAS FILTER DIRTY	●			●	●		●					●
IGNITION TRANSFORMER FAULT			●									
IGNITION ELECTRODES BAD POSITION			●									
DETECTION ELECTRODE BAD POSITION						●					●	
BUTTERFLY VALVE BAD SETTING			●			●						
DEFECTIVE GAS GOVERNOR			●	●	●							●
GAS VALVE DEFECTIVE			●									
BAD CONNECTION OR DEFECTIVE HIGH/LOW FLAME THERMOSTAT OR PRESSURE SWITCH (IF PROVIDED)							♦	●	●	♦		
WRONG SETTING SERVO CONTROL CAM							l	l	l			
UV PROBE DIRTY OR DEFECTIVE (IF PROVIDED)			l			l					l	
PHASE-NEUTRAL INVERTED						s						
PHASE-PHASE SUPPLY OR PRESENCE OF VOLTAGE ON THE NEUTRAL CONDUCTOR(*)						s						

l = with any control box;

s = with only LGB2../LMG2../LME11/LME2..

(*) In such cases, insert the circuit SIEMENS "RC466890660" () See chapter "Electrical connections"

BURNER EXPLODED VIEW

P61 - P65 - P71

Pos.	Description
1.1	FAN
1.2	MOTOR
2.1	VALVE GROUP
2.2	THREADED PIPE
2.3	ELBOW
2.4	M/F REDUCTION
2.5	VALVE GROUP FLANGE
2.6	GAS PROVING SYSTEM
3	AIR INLET
4	HOUSING
4.1	COVER
5	GASKET
6	AIR PRESSURE SWITCH PIPE
7	PLEXYGLASS
8	BLAST TUBE
9	AIR PRESSURE SWITCH
10.1	OR RING
10.2	BUTTERFLY VALVE
10.3	GAS MANIFOLD
11.1.1	COMPLETE MOUNTED LEVERAGE
11.1.2	ADJUSTING CAM
11.1.3	ACTUATOR
11.1.4	ACTUATOR CONNECTOR
11.1.5	BRACKET
11.2.1	AIR ADJUSTING CAM REGULATING NUT
11.2.2	AIR ADJUSTING CAM SCREW
11.2.3	AIR ADJUSTING CAM REGULATING SCREW

Pos.	Description
11.2.4	TRANSMISSION AIR ADJUSTING CAM
11.2.5	CONNECTING ROD
11.2.6	ROD
11.2.7	JOINT
11.2.8	ROD JOINT
11.3	INDEX PLATE
11.4	INNER AIR DAMPER
11.5	INDEX BUSH
11.6	BUSH
11.7	BOX
11.8	DAMPER PIVOT
11.9	BUTTERFLY TRANSMISSION PIVOT
11.10	ACTUATOR PIVOT
11.11	CONNECTING ROD
11.12	ROD
11.13	ROD
11.14	JOINT
11.15	ROD JOINT
12	PREMOUNTED HEAD ADJUSTING SCREWS
13.1	FRONT PANEL
13.2	CONTROL PANEL
13.3	CONTROL PANEL COVER
14.1	DETECTION ELECTRODE
14.2	IGNITION ELECTRODE
14.3	GROUNDING ELECTRODE
14.4	COMBUSTION HEAD
15	BLACK/GREEN CONNECTOR

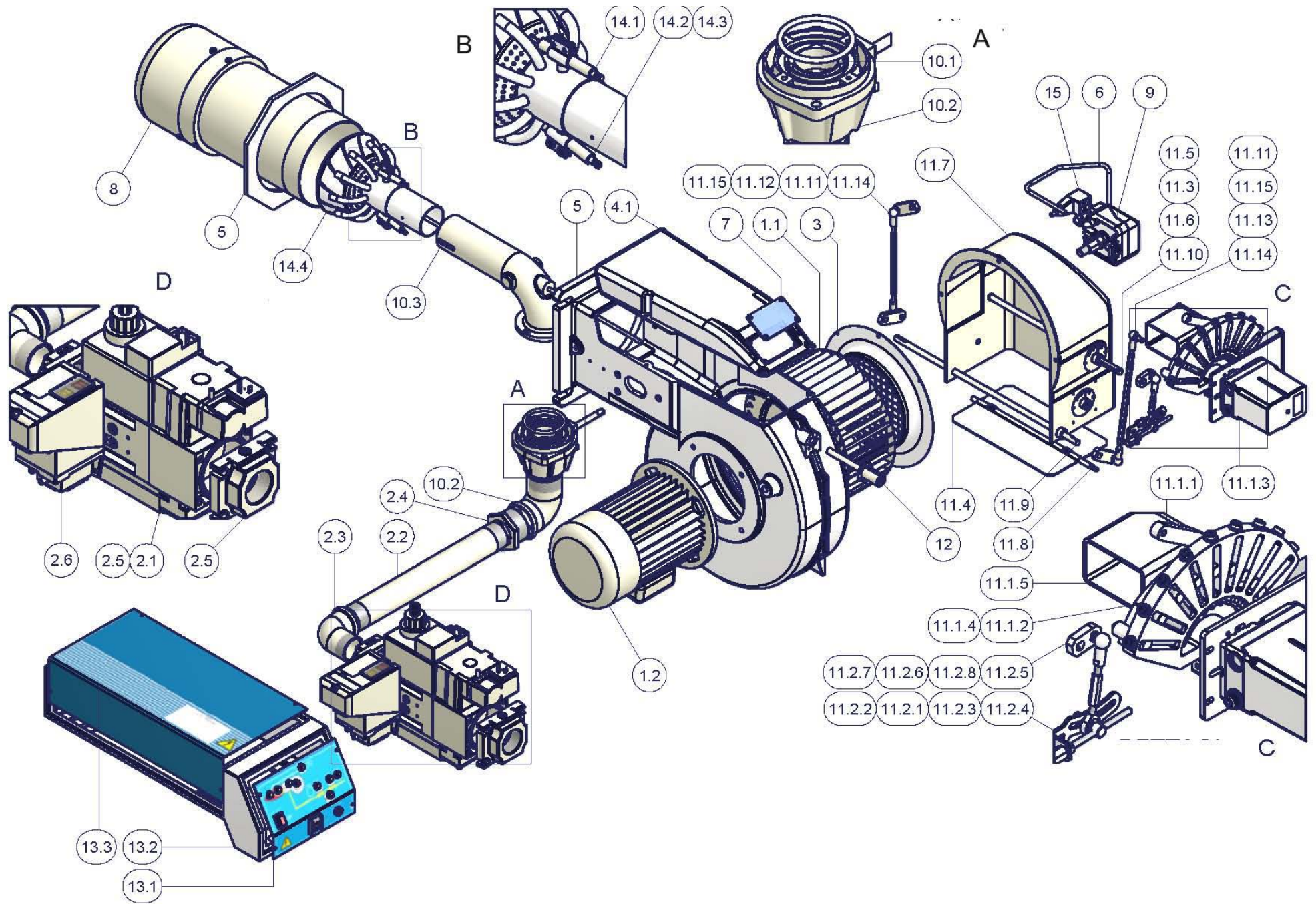

R73A

1	BUTTERFLY GAS VALVE
2	BOARD
2.1	COVER
2.3	BOARD
2.4.1	FRONT CONTROL PANEL
2.4.2	LIGHT
2.4.3	LIGHT
2.4.4	FLAME UNLOCK BUTTON
2.4.6	SWITCH
2.4.7	FUSE
2.5	CONTROL BOX
2.7	IGNITION TRANSFORMER
2.8	PRINTED CIRCUIT BOARD
3.4	GAS PROVING SYSTEM
3.5	GAS VALVES GROUP WITH GOVERNOR
4.1	GAS MANIFOLD
4.2.2	IGNITION ELECTRODE
4.3	DETECTION ELECTRODE
4.4	STANDARD COMBUSTION HEAD
4.5	O RING
5	SPACER
6	O RING

7	SPACER
8.1	FLANGE
8.2	HEAD ADJUSTING RING NUT
8.7	BURNER HOUSING
8.8	GENERATOR GASKET
8.9	NET
8.10	PLATE
8.11	INSPECTION GLASS
10	STANDARD BLAST TUBE
12.1	FLANGE
12.2	MOTOR
12.3	FAN WHEEL
13	IGNITION CABLE
15	SILENCER
18	AIR PRESSURE SWITCH
18.2	AIR PRESSURE SWITCH
20	
21.3	LEVERAGE
21.4	ADJUSTING CAM
21.4.14	ADJUSTING CAM FOIL
21.14	ACTUATOR

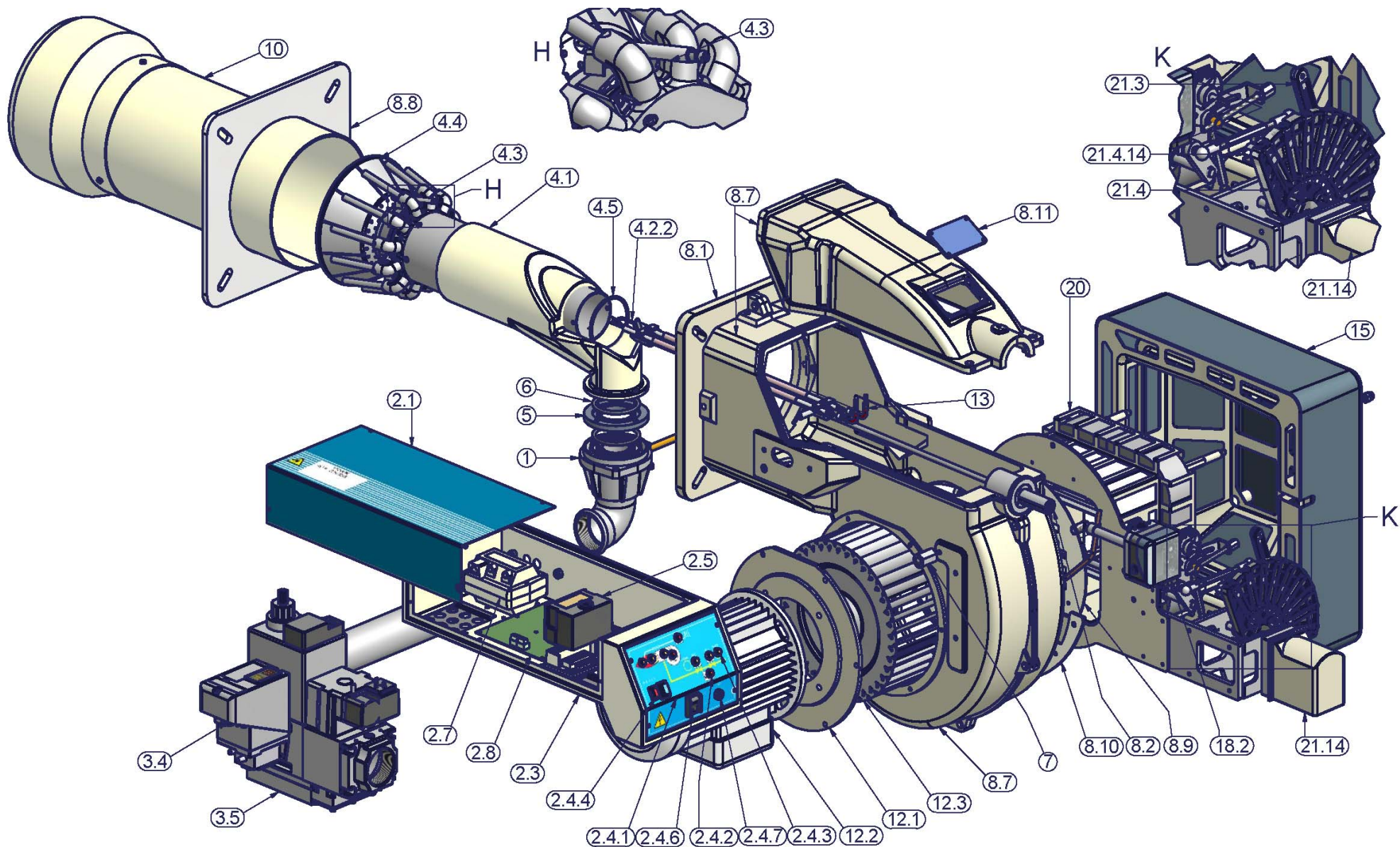

WIRING DIAGRAMS

ATTENTION:

- 1 - Power supply: 400V 50Hz 3N a.c.three-phase and 230V 50Hz 1N a.c. monophas
- 2 - Don't reverse phase and neutral
- 3 - Ensure the burner is properly earthed

VERSIONE ALTA-BASSA FIAMMA "AB" / PROGRESSIVO "PR"
 "AB" HIGH-LOW / "PR" PROGRESSIVE VERSION

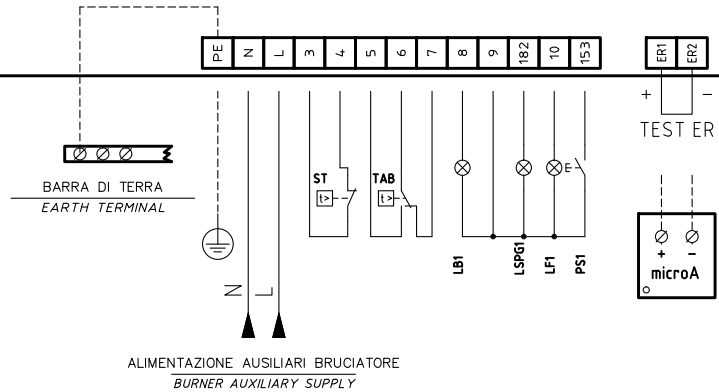
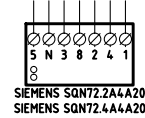
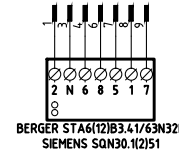
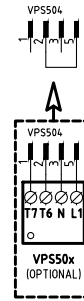
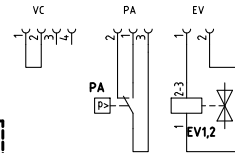
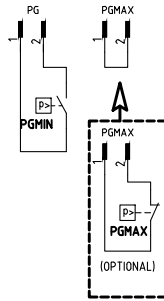
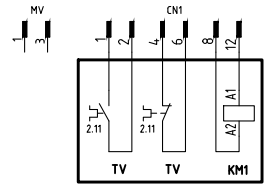
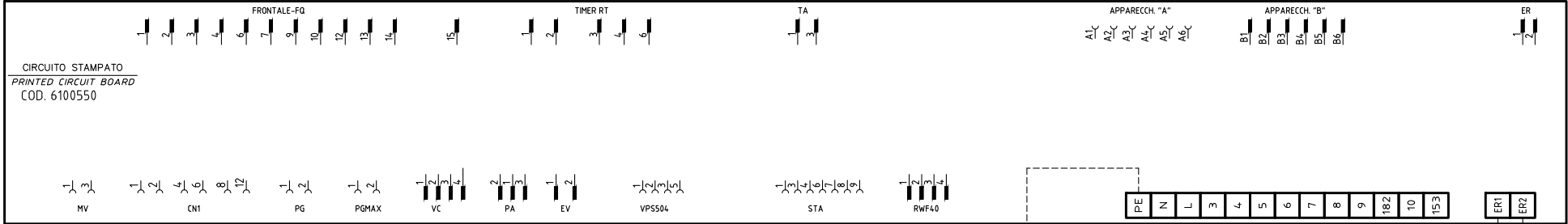
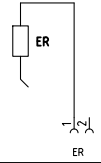
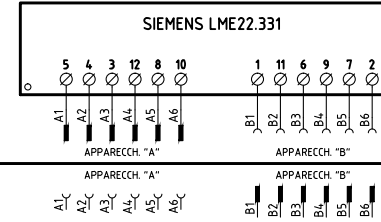
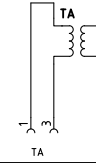
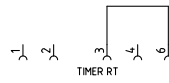
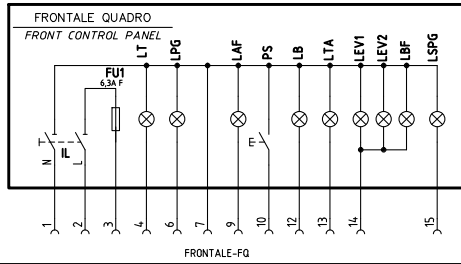

VEDI FOGLIO [3]
SEE SHEET [3]

Data	18/01/2012	PREC.	FOGLIO
Revisione	03	/	1
Dis. N.	18 - 236	SEGUE	TOTALE
		2	5

VERSIONE MODULANTE "MD"
"MD" MODULATING VERSION

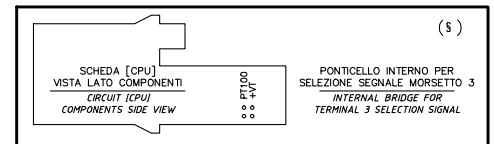
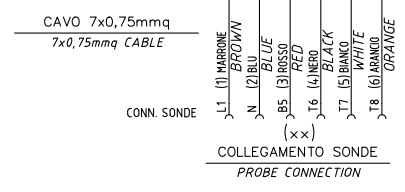
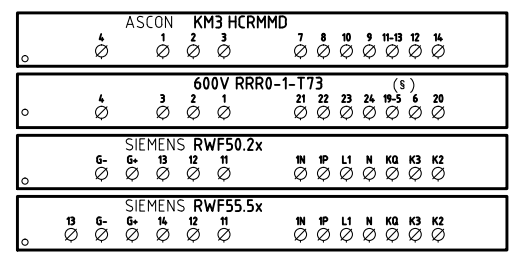
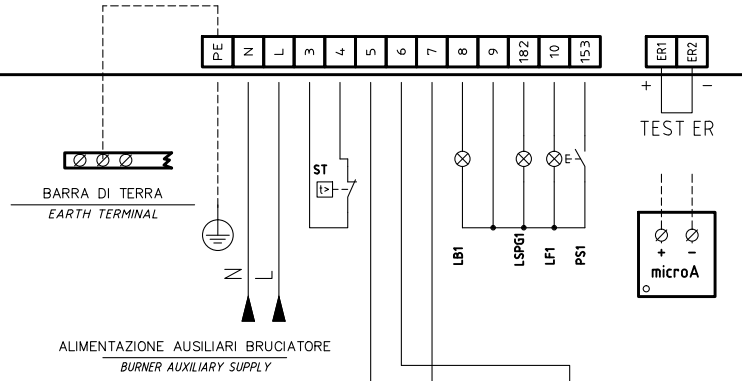
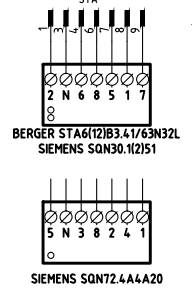
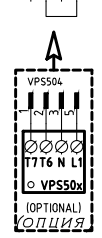
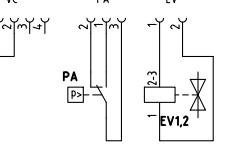
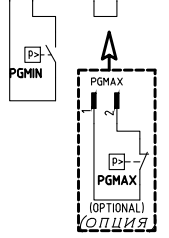
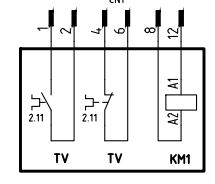
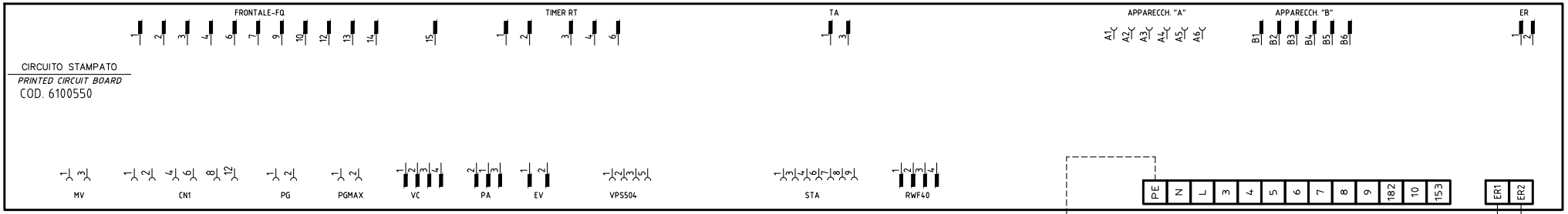
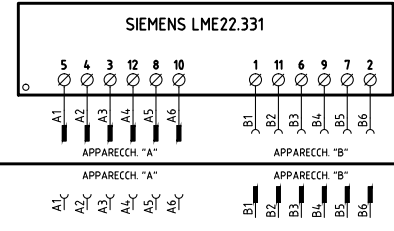
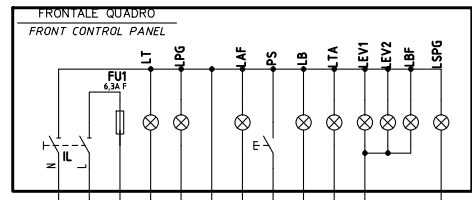

Data	18/01/2012	PREC.	FOGLIO
Revisione	03	1	2
Dis. N.	18 - 236	SEQUE	TOTALE
		3	5

CIRCUITO STAMPATO
PRINTED CIRCUIT BOARD
COD. 6100550

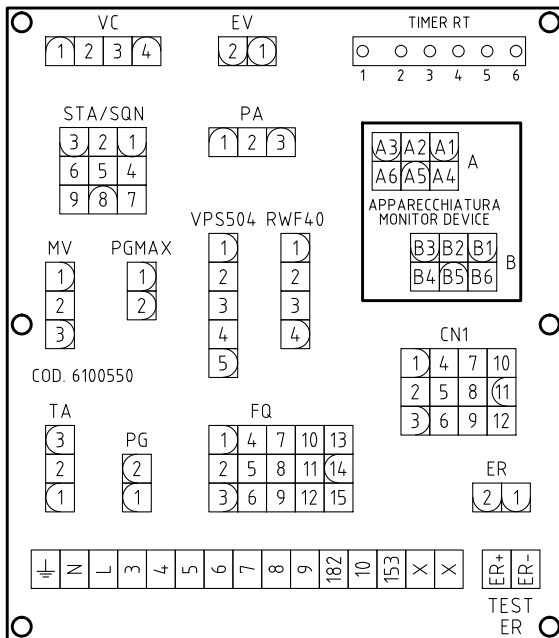
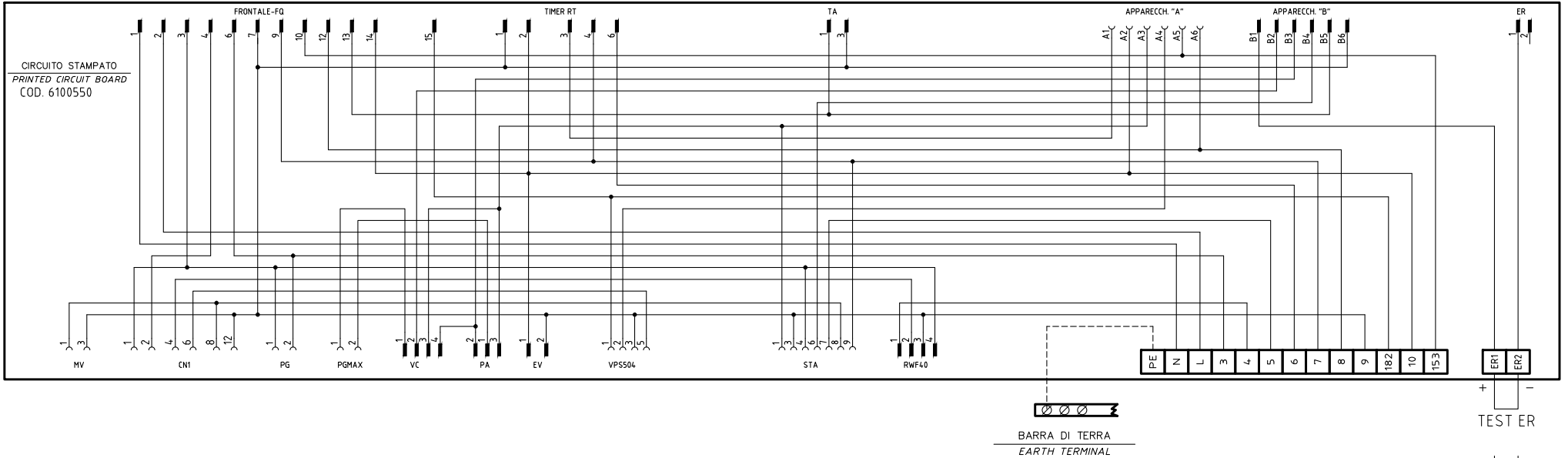

SERVOCOMANDO SERRANDA ARIA

AIR DAMPER ACTUATOR
BERGER STA6(12)B3.41/63N32L

- ST2 ALTA FIAMMA
HIGH FLAME
- ST0 SOSTA
STAND-BY
- ST1 BASSA FIAMMA
LOW FLAME
- MV NON USATA
NOT USED

SERVOCOMANDO SERRANDA ARIA (ALTERNATIVO)

AIR DAMPER ACTUATOR (ALTERNATIVE)
SIEMENS SQN30.1(2)51A

- I ALTA FIAMMA
HIGH FLAME
- II SOSTA
STAND-BY
- III BASSA FIAMMA
LOW FLAME
- V NON USATA
NOT USED

SERVOCOMANDO SERRANDA ARIA (ALTERNATIVO)

AIR DAMPER ACTUATOR (ALTERNATIVE)
SIEMENS SQN72.xA4A20

- I (ROSSO) ALTA FIAMMA
I (RED) HIGH FLAME
- II (BLU) SOSTA
II (BLUE) STAND-BY
- III (ARANCIO) BASSA FIAMMA
III (ORANGE) LOW FLAME
- IV (NERO) NON USATA
IV (BLACK) NOT USED

Data	18/01/2012	PREC.	FOGLIO
Revisione	03	2	3
Dis. N.	18 - 236	SEGUE	TOTALE
		4	5

(x x)
 ATTENZIONE COLLEGAMENTO SONDE CON CONNETTORE 7 POLI
 WARNING PROBE CONNECTION WITH 7 PINS CONNECTOR

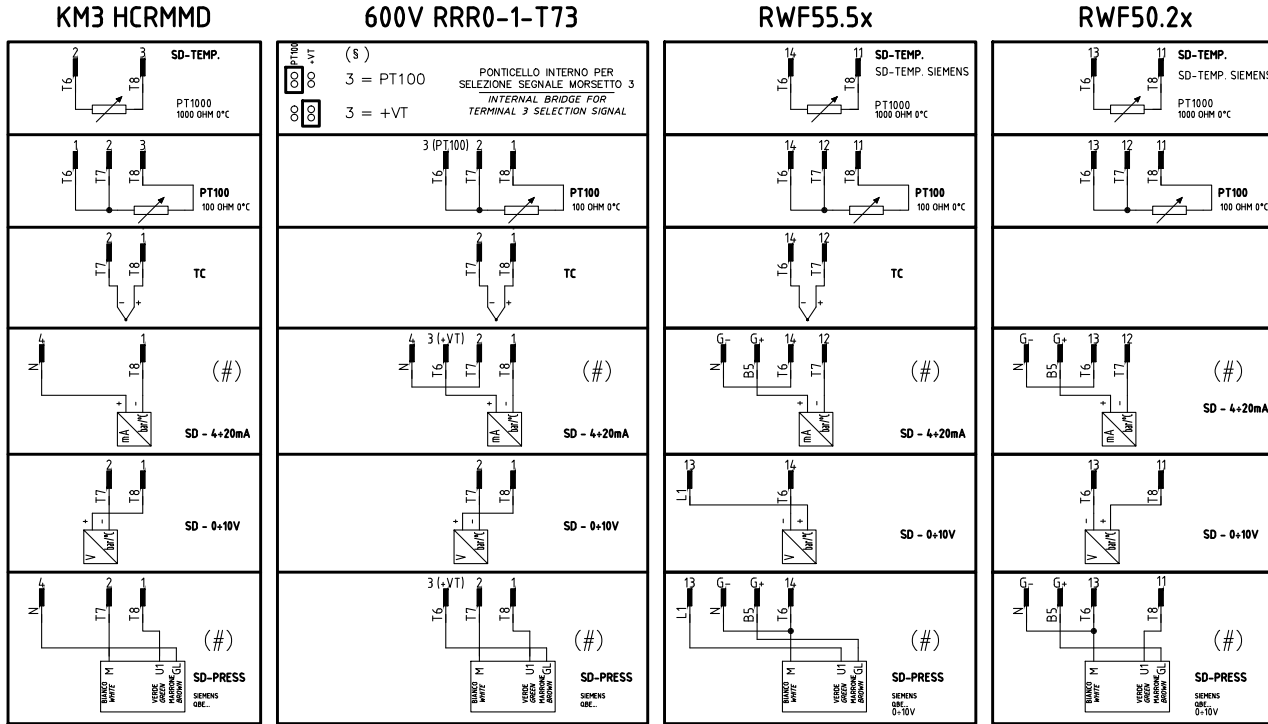

(#)
 COLLEGAMENTO SOLO PER
 TRASDUTTORI PASSIVI
 TRANSDUCER PASSIVE
 CONNECTION ONLY

QG - MC1
 MORSETTIERA COLLEGAMENTO LINEA E MOTORE TRIFASE
 MOTOR THREE PHASES AND ELECTRIC SUPPLY CONNECTION TERMINAL BOARD

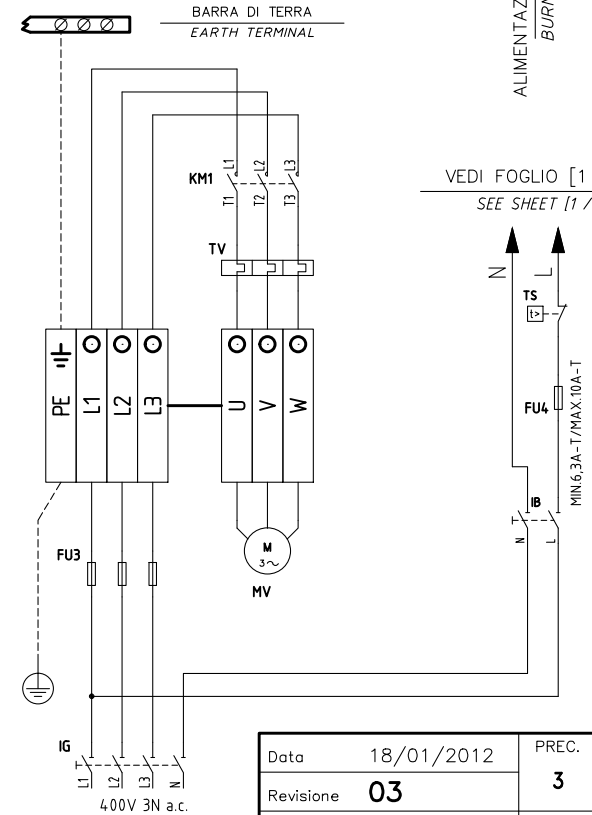

ALIMENTAZIONE AUSILIARI BRUCIATORE
 BURNER AUXILIARY SUPPLY

VEDI FOGLIO [1 / 2]
 SEE SHEET [1 / 2]

Data	18/01/2012	PREC.	FOGLIO
Revisione	03	3	4
Dis. N.	18 - 236	SEGUE	TOTALE
		5	5

Sigla/Item	Funzione	Function
600V RRR0-1-T73	REGOLATORE MODULANTE (ALTERNATIVO)	BURNER MODULATOR (ALTERNATIVE)
BERGER STA6(12)B3.41/63N32L	SERVOCOMANDO SERRANDA ARIA	AIR DAMPER ACTUATOR
ER	ELETTRODO RILEVAZIONE FIAMMA	FLAME DETECTION ELECTRODE
EV1,2	ELETTROVALVOLE GAS (O GRUPPO VALVOLE)	GAS ELECTRO-VALVES (OR VALVES GROUP)
FU1	FUSIBILE DI LINEA	LINE FUSE
FU2	FUSIBILE AUSILIARIO	AUXILIARY FUSE
FU3	FUSIBILI LINEA MOTORE VENTILATORE	FAN MOTOR LINE FUSES
FU4	FUSIBILE DI LINEA	LINE FUSE
IB	INTERRUTTORE LINEA BRUCIATORE	BURNER LINE SWITCH
IG	INTERRUTTORE GENERALE	MAINS SWITCH
IL	INTERRUTTORE LINEA AUSILIARI	AUXILIARY LINE SWITCH
KM1	CONTATTORE MOTORE VENTILATORE	FAN MOTOR CONTACTOR
KM3 HCRMMD	REGOLATORE MODULANTE (ALTERNATIVO)	BURNER MODULATOR (ALTERNATIVE)
LAF	LAMPADA SEGNALAZIONE ALTA FIAMMA BRUCIATORE	BURNER IN HIGH FLAME INDICATOR LIGHT
LB	LAMPADA SEGNALAZIONE BLOCCO BRUCIATORE	INDICATOR LIGHT FOR BURNER LOCK-OUT
LB1	LAMPADA SEGNALAZIONE BLOCCO BRUCIATORE	INDICATOR LIGHT FOR BURNER LOCK-OUT
LBF	LAMPADA SEGNALAZIONE BASSA FIAMMA BRUCIATORE	BURNER IN LOW FLAME INDICATOR LIGHT
LEV1	LAMPADA SEGNALAZIONE APERTURA [EV1]	INDICATOR LIGHT FOR OPENING OF ELECTRO-VALVE [EV1]
LEV2	LAMPADA SEGNALAZIONE APERTURA [EV2]	INDICATOR LIGHT FOR OPENING OF ELECTRO-VALVE [EV2]
LF1	LAMPADA SEGNALAZIONE FUNZIONAMENTO BRUCIATORE	INDICATOR LIGHT BURNER OPERATION
LPG	LAMPADA SEGNALAZIONE PRESENZA GAS IN RETE	INDICATOR LIGHT FOR PRESENCE OF GAS IN THE NETWORK
LSPG	LAMPADA SEGNALAZIONE BLOCCO CONTROLLO TENUTA VALVOLE	INDICATOR LIGHT FOR LEAKAGE OF VALVES
LSPG1	LAMPADA SEGNALAZIONE BLOCCO CONTROLLO TENUTA VALVOLE	INDICATOR LIGHT FOR LEAKAGE OF VALVES
LT	LAMPADA SEGNALAZIONE BLOCCO TERMICO	INDICATOR LIGHT FOR MOTOR OVERLOAD THERMAL CUTOUT
LTA	LAMPADA SEGNALAZIONE TRASFORMATORE DI ACCENSIONE	IGNITION TRANSFORMER INDICATOR LIGHT
MV	MOTORE VENTILATORE	FAN MOTOR
PA	PRESSOSTATO ARIA	AIR PRESSURE SWITCH
PGMAX	PRESSOSTATO GAS DI MASSIMA PRESSIONE	MAXIMUM PRESSURE GAS SWITCH
PGMIN	PRESSOSTATO GAS DI MINIMA PRESSIONE	MINIMUM GAS PRESSURE SWITCH
PS	PULSANTE SBLOCCO FIAMMA	FLAME UNLOCK BUTTON
PS1	PULSANTE SBLOCCO FIAMMA	FLAME UNLOCK BUTTON
PT100	SONDA DI TEMPERATURA	TEMPERATURE PROBE
RWF50.2x	REGOLATORE MODULANTE (ALTERNATIVO)	BURNER MODULATOR (ALTERNATIVE)
RWF55.5x	REGOLATORE MODULANTE (ALTERNATIVO)	BURNER MODULATOR (ALTERNATIVE)
SD-PRESS	SONDA DI PRESSIONE	PRESSURE PROBE
SD-TEMP.	SONDA DI TEMPERATURA	TEMPERATURE PROBE
SD - 0÷10V	TRASDUTTORE USCITA IN TENSIONE	TRANSDUCER VOLTAGE OUTPUT
SD - 4÷20mA	TRASDUTTORE USCITA IN CORRENTE	TRANSDUCER CURRENT OUTPUT
SIEMENS LME22.331	APPARECCHIATURA CONTROLLO FIAMMA	CONTROL BOX
SIEMENS SQN30.1(2)51	SERVOCOMANDO SERRANDA ARIA (ALTERNATIVO)	AIR DAMPER ACTUATOR (ALTERNATIVE)
SIEMENS SQN72.2A4A20	SERVOCOMANDO SERRANDA ARIA (ALTERNATIVO)	AIR DAMPER ACTUATOR (ALTERNATIVE)
SIEMENS SQN72.4A4A20	SERVOCOMANDO SERRANDA ARIA (ALTERNATIVO)	AIR DAMPER ACTUATOR (ALTERNATIVE)
SMA	SELETTORE MANUALE/AUTOMATICO	MANUAL/AUTOMATIC SWITCH
SMF	SELETTORE MANUALE FUNZIONAMENTO MIN-0-MAX	MIN-0-MAX MANUAL OPERATION SWITCH
ST	SERIE TERMOSTATI/PRESSOSTATI	SERIES OF THERMOSTATS OR PRESSURE SWITCHES
TA	TRASFORMATORE DI ACCENSIONE	IGNITION TRANSFORMER
TAB	TERMOSTATO/PRESSOSTATO ALTA-BASSA FIAMMA	HIGH-LOW THERMOSTAT/PRESSURE SWITCHES
TC	TERMOCOPPIA	THERMOCOUPLE
TS	TERMOSTATO/PRESSOSTATO DI SICUREZZA	SAFETY THERMOSTAT OR PRESSURE SWITCH
TV	TERMICO MOTORE VENTILATORE	FAN MOTOR THERMAL
VPS50x	CONTROLLO DI TENUTA VALVOLE GAS (OPTIONAL)	GAS PROVING SYSTEM (OPTIONAL)
microA	MICROAMPEROMETRO	MICROAMMETER

Data	18/01/2012	PREC.	FOGLIO
Revisione	03	4	5
Dis. N.	18 - 236	SEGUE	TOTALE
		/	5

APPENDIX

SIEMENS LME11/21/22 CONTROL BOX

Preconditions for burner startup

- Burner control must be reset
- All contacts in the line are closed, request for heat
- No undervoltage
- Air pressure switch LP must be in its "no-load" position
- Fan motor or AGK25 is closed
- Flame detector is darkened and there is no extraneous light

Undervoltage

Safety shutdown from the operating position takes place should mains voltage drop below about AC 175 V (at UN = AC 230 V)

Restart is initiated when mains voltage exceeds about AC 185 V (at UN = AC 230 V).

Controlled intermittent operation

After no more than 24 hours of continuous operation, the burner control will initiate automatic controlled shutdown followed by a restart.

Reversed polarity protection with ionization





If the connections of live conductor (terminal 12) and neutral conductor (terminal 2) are mixed up, the burner control will initiate lockout at the end of the safety time "TSA".

Control sequence in the event of fault

If lockout occurs, the outputs for the fuel valves, the burner motor and the ignition equipment will immediately be deactivated (< 1 second).

Operational status indication

In normal operation, the different operating states are showed by means of the multicolor LED, inside the lockout reset button:

	red LED	Steady on
	yellow LED
	green LED	○... Off
		

During startup, status indication takes place according to the table:

Status	Color code	Color
Waiting time tw, other waiting states	○.....	Off
Ignition phase, ignition controlled	●●●●●●●●●●	Flashing yellow
Operation, flame ok	□.....	Green
Operation, flame not ok	□○□○□○□○□○	Flashing green
Extraneous light on burner startup	□▲□▲□▲□▲□▲	Green - red
Undervoltage	●▲●▲●▲●▲●▲	Yellow - red
Fault, alarm	▲.....	Red
Error code output (refer to "Error code table")	▲○ ▲○ ▲○ ▲○	Flashing red

START-UP PROGRAM

As far as the startup program, see its time diagram:

A Start command (switching on)

This command is triggered by control thermostat / pressure controller «R». Terminal 12 receives voltage and the programming mechanism starts running. On completion of waiting time «tw» with the LME21..., or after air damper «SA» has reached the nominal load position (on comple-

tion of «t11») with the LME22..., fan motor «M» will be started.

tw Waiting time

During the waiting time, air pressure monitor «LP» and flame relay «FR» are tested for correct contact positions.

t11 Programmed opening time for actuator «SA»

(Only with LME22...) The air damper opens until the nominal load position is reached. Only then will fan motor «M» be switched on.

t10 Specified time for air pressure signal

On completion of this period of time, the set air pressure must have built up, or else lockout will occur.

t1 Prepurge time

Purging the combustion chamber and the secondary heating surfaces: required with low-fire air volumes when using the LME21... and with nominal load air volumes when using the LME22.... The diagrams show the so-called prepurge time «t1» during which air pressure monitor «LP» must indicate that the required air pressure is available. The effective prepurge time «t1» comprises interval end «tw» through «t3».

t12 Programmed closing time for actuator «SA»

(Only with LME22...) During «t12», the air damper travels to the low-fire position.

t3 Preignition time

During «t3» and up to the end of «TSA», flame relay «FR» is forced to close. On completion of «t3», the release of fuel is triggered at terminal 4.

TSA Ignition safety time

On completion of «TSA», a flame signal must be present at terminal 1. That flame signal must be continuously available until shutdown occurs, or else flame relay «FR» will be deenergized, resulting in lockout.

t4 Interval BV1 and BV2-LR

Time between the end of TSA and the signal to the second fuel valve BV2 or to the load controller LR

B - B' Interval for flame establishment

C Burner operation position

C - D Burner operation (heat production)

D Controlled by "R" shutdown

The burner stops and the control device is ready for a new startup.

LME11 control sequence

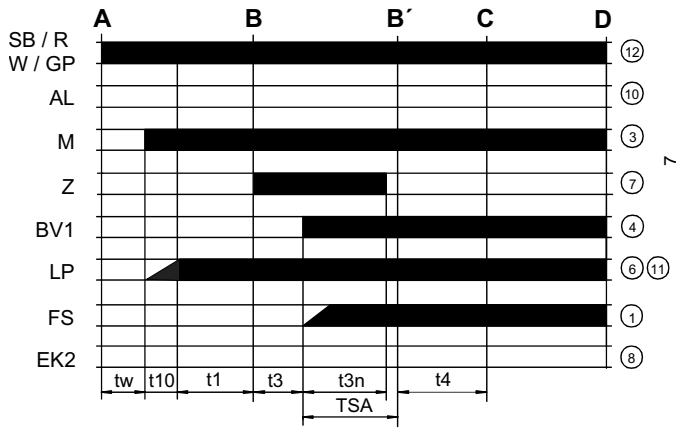

LME21 control sequence

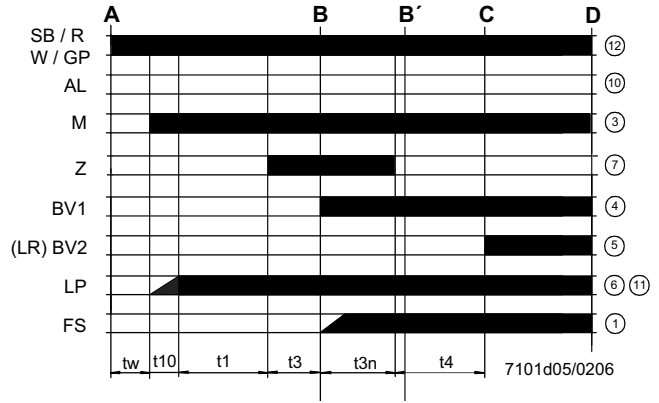

LME22 control sequence

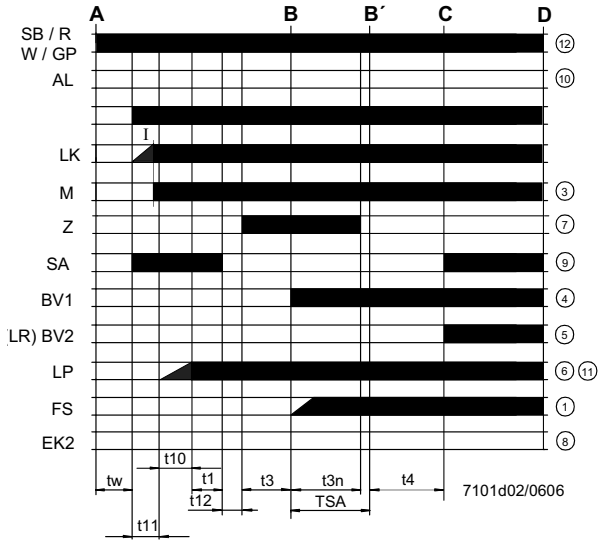

Control sequence

- t_w Waiting time
- t_1 Purge time
- TSA Ignition safety time
- t_3 Preignition time
- t_{3n} Postignition time
- t_4 Interval between BV1 and BV2/LR
- t_{10} Specified time for air pressure signal
- t_{11} Programmed opening time for actuator SA
- t_{12} Programmed closing time for actuator SA

LME11 connection diagram

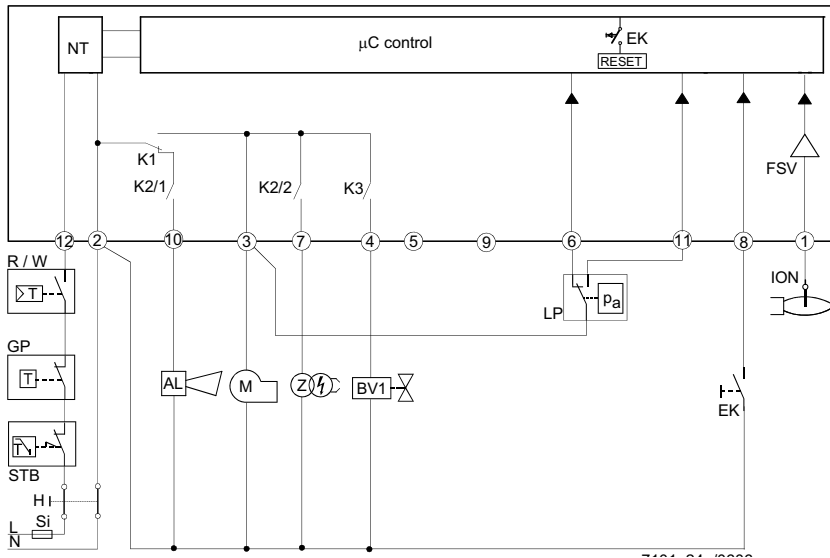

Connection diagram

- AL Error message (alarm)
- BV Fuel valve
- EK2 Remote lockout reset button
- FS Flame signal
- GP Gas pressure switch
- LP Air pressure switch
- LR Load controller
- M Fan motor
- R Control thermostat/pressurestat
- SB Safety limit thermostat
- W Limit thermostat /pressure switch
- Z Ignition transformer

LME21 connection diagram

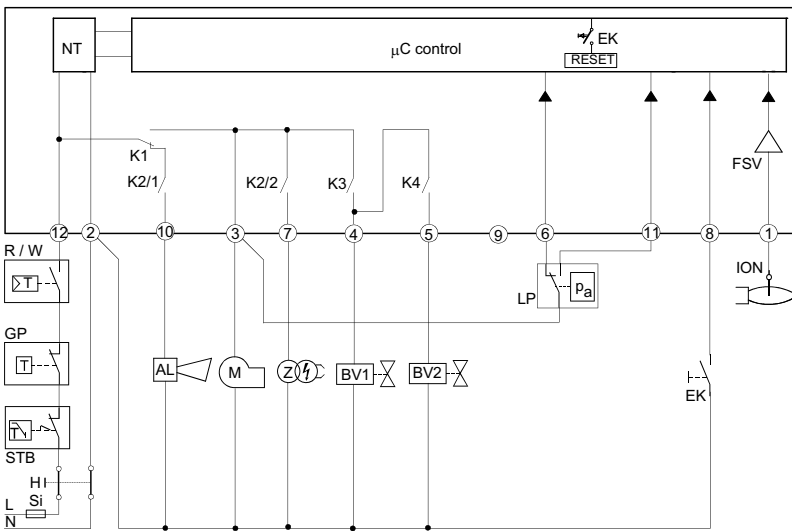

LME22 connection diagram

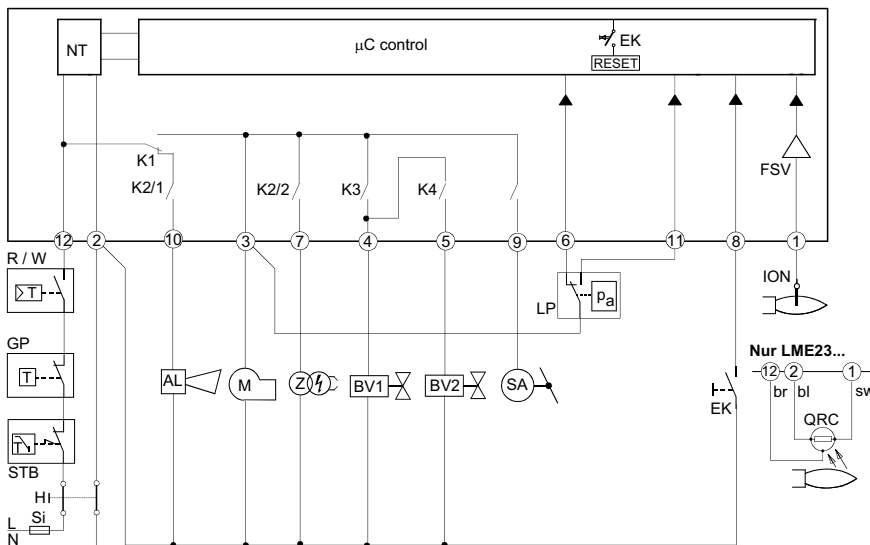

CONTROL PROGRAM IN THE EVENT OF FAULT

- If a fault occurs, all outputs will immediately be deactivated (in less than 1s).
- After an interruption of power, a restart will be made with the full program sequence.
- If the operating voltage drops below the undervoltage threshold, a safety shutdown is performed.
- If the operating voltage exceeds the undervoltage threshold, a restart will be performed.
- In case of extraneous light during "t1", a lockout occurs.
- In case of extraneous light during "tw", there is a prevention of startup and a lockout after 30 seconds.
- In case of no flame at the end of TSA, there will be max. 3 repetitions of the startup cycle, followed by a lockout at the end of TSA, for mod. LME11..; directly a lockout at the end of TSA for LME21-22 models.
- For LME11 model: if a loss of flame occurs during operation, in case of an establishment of flame at the end of TSA, there will be max. 3 repetitions, otherwise a lockout will occur.
- For LME21-22 models: if a loss of flame occurs during operation, there will be a lockout.
- If the contact of air pressure monitor LP is in working position, a prevention of startup and lockout after 65 seconds will occur.
- If the contact of air pressure monitor LP is in normal position, a lockout occurs at the end of t10.
- If no air pressure signal is present after completion of t1, a lockout will occur.

CONTROL BOX LOCKED

In the event of lockout, the LME.. remains locked and the red signal lamp (LED) will light up. The burner control can immediately be reset. This state is also maintained in the case of mains failure.

DIAGNOSTICS OF THE CASE OF FAULT

- Press the lockout reset button for more than 3 seconds to activate the visual diagnostics.
- Count the number of blinks of the red signal lamp and check the fault condition on the "Error code table" (the device repeats the blinks for regular intervals).

During diagnostics, the control outputs are deactivated:

- the burner remains shut down;
- external fault indication is deactivated;
- fault status is showed by the red LED, inside the LME's lockout reset button according to the "Error code table":

ERROR CODE TABLE	
2 blinks **	No establishment of flame at the end of TSA - Faulty or soiled fuel valves - Faulty or soiled flame detector - Inadequate adjustment of burner, no fuel - Faulty ignition equipment
3 blinks ***	The air pressure switch does not switch or remains in idle position: - LP is faulty - Loss of air pressure signal after t10 - LP is welded in normal position.
4 blinks ****	- Extraneous light when burner starts up.
5 blinks *****	- LP is working position.
6 blinks *****	Free.
7 blinks *****	Loss of flame during operation - Faulty or soiled fuel valves - Faulty or soiled flame detector - Inadequate adjustment of burner
8 ÷ 9 blinks	Free
10 blinks *****	Faulty output contacts Attention: "lockout" remote signal (terminal no. 10) not enabled - Wiring error - Anomalous voltage on output terminals - Other faults
14 blinks ***** (only for LME4x)	- CPI contact (gas valve microswitch) not closed.

RESETTING THE BURNER CONTROL

When lockout occurs, the burner control can immediately be reset, by pressing the lockout reset button for about 1..3 seconds. The LME.. can only be reset when all contacts in the line are closed and when there is no undervoltage.

LIMITATION OF REPETITIONS (only for LME11.. model)

If no flame is established at the end of TSA, or if the flame is lost during operation, a maximum of 3 repetitions per controller startup can be performed via "R", otherwise lockout will be initiated. Counting of repetitions is restarted each time a controlled startup via "R" takes place.

⚠ Condensation, formation of ice and ingress of water are not permitted!

TECHNICAL CHARACTERISTICS

Mains voltage	120V AC +10% / -15% 230V AC +10% / -15%
Frequency	50 ... 60 Hz +/- 6%
Power consumption	12VA
External primary fuse	max. 10 A (slow)
input current at terminal 12	max. 5 A
Detection cable length	max. 3m (for electrode)
Detection cable length	max. 20 m (laid separately, for QRA probe)
Reset cable length	max. 20 m (posato separatamente)
Term. 8 & 10 cable length	max. 20 m
Thermostat cable length and other terminals	max. 3 m
Safety class	I
Index of protection	IP40 (to be ensured during mounting)
Operating conditions	-20... +60 °C, < 95% UR
Storage conditions	-20... +60 °C, < 95% UR
Weight	approx. 160 g



C.I.B. UNIGAS S.p.A.
Via L.Galvani, 9 - 35011 Campodarsego (PD) - ITALY
Tel. +39 049 9200944 - Fax +39 049 9200945/9201269
web site: www.cibunigas.it - e-mail: cibunigas@cibunigas.it

Note: Specifications and data subject to change. Errors and omissions excepted.