



KR1025
KR1030
KR1040

***Progressive
and fully-modulating
gas - heavy oil burners***

MANUAL OF INSTALLATION - USE - MAINTENANCE

CIB UNIGAS

BURNERS - BRUCIATORI - BRULERS - BRENNER - QUEMADORES - ГОРЕЛКИ

WARNINGS

THIS MANUAL IS SUPPLIED AS AN INTEGRAL AND ESSENTIAL PART OF THE PRODUCT AND MUST BE DELIVERED TO THE USER.

INFORMATION INCLUDED IN THIS SECTION ARE DEDICATED BOTH TO THE USER AND TO PERSONNEL FOLLOWING PRODUCT INSTALLATION AND MAINTENANCE.

THE USER WILL FIND FURTHER INFORMATION ABOUT OPERATING AND USE RESTRICTIONS, IN THE SECOND SECTION OF THIS MANUAL. WE HIGHLY RECOMMEND TO READ IT.

CAREFULLY KEEP THIS MANUAL FOR FUTURE REFERENCE.

1) GENERAL INTRODUCTION

- The equipment must be installed in compliance with the regulations in force, following the manufacturer's instructions, by qualified personnel.
- Qualified personnel means those having technical knowledge in the field of components for civil or industrial heating systems, sanitary hot water generation and particularly service centres authorised by the manufacturer.
- Improper installation may cause injury to people and animals, or damage to property, for which the manufacturer cannot be held liable.
- Remove all packaging material and inspect the equipment for integrity.

In case of any doubt, do not use the unit - contact the supplier.

The packaging materials (wooden crate, nails, fastening devices, plastic bags, foamed polystyrene, etc), should not be left within the reach of children, as they may prove harmful.

- Before any cleaning or servicing operation, disconnect the unit from the mains by turning the master switch OFF, and/or through the cut-out devices that are provided.
- Make sure that inlet or exhaust grilles are unobstructed.
- In case of breakdown and/or defective unit operation, disconnect the unit. Make no attempt to repair the unit or take any direct action.

Contact qualified personnel only.

Units shall be repaired exclusively by a servicing centre, duly authorised by the manufacturer, with original spare parts.

Failure to comply with the above instructions is likely to impair the unit's safety.

To ensure equipment efficiency and proper operation, it is essential that maintenance operations are performed by qualified personnel at regular intervals, following the manufacturer's instructions.

- When a decision is made to discontinue the use of the equipment, those parts likely to constitute sources of danger shall be made harmless.
- In case the equipment is to be sold or transferred to another user, or in case the original user should move and leave the unit behind, make sure that these instructions accompany the equipment at all times so that they can be consulted by the new owner and/or the installer.
- For all the units that have been modified or have options fitted then original accessory equipment only shall be used.
- This unit shall be employed exclusively for the use for which it is meant. Any other use shall be considered as improper and, therefore, dangerous.

The manufacturer shall not be held liable, by agreement or otherwise, for damages resulting from improper installation, use and failure to comply with the instructions supplied by the manufacturer.

2) SPECIAL INSTRUCTIONS FOR BURNERS

- The burner should be installed in a suitable room, with ventilation openings complying with the requirements of the regulations in force, and sufficient for good combustion.
- Only burners designed according to the regulations in force should be used.
- This burner should be employed exclusively for the use for which it was designed.
- Before connecting the burner, make sure that the unit rating is the same as delivery mains (electricity, gas oil, or other fuel).
- Observe caution with hot burner components. These are, usually, near to the flame and the fuel pre-heating system, they become hot during the unit operation and will remain hot for some time after the burner has stopped.

When the decision is made to discontinue the use of the burner, the user

shall have qualified personnel carry out the following operations:

- a Remove the power supply by disconnecting the power cord from the mains.
- b) Disconnect the fuel supply by means of the hand-operated shut-off valve and remove the control handwheels from their spindles.

Special warnings

- Make sure that the burner has, on installation, been firmly secured to the appliance, so that the flame is generated inside the appliance firebox.
- Before the burner is started and, thereafter, at least once a year, have qualified personnel perform the following operations:
 - a set the burner fuel flow rate depending on the heat input of the appliance;
 - b set the flow rate of the combustion-supporting air to obtain a combustion efficiency level at least equal to the lower level required by the regulations in force;
 - c check the unit operation for proper combustion, to avoid any harmful or polluting unburnt gases in excess of the limits permitted by the regulations in force;
 - d make sure that control and safety devices are operating properly;
 - e make sure that exhaust ducts intended to discharge the products of combustion are operating properly;
 - f on completion of setting and adjustment operations, make sure that all mechanical locking devices of controls have been duly tightened;
 - g make sure that a copy of the burner use and maintenance instructions is available in the boiler room.
- In case of a burner shut-down, reset the control box by means of the RESET pushbutton. If a second shut-down takes place, call the Technical Service, **without trying to RESET further**.
- The unit shall be operated and serviced by qualified personnel only, in compliance with the regulations in force.

3) GENERAL INSTRUCTIONS DEPENDING ON FUEL USED

3a) ELECTRICAL CONNECTION

- For safety reasons the unit must be efficiently earthed and installed as required by current safety regulations.
 - It is vital that all safety requirements are met. In case of any doubt, ask for an accurate inspection of electricians by qualified personnel, since the manufacturer cannot be held liable for damages that may be caused by failure to correctly earth the equipment.
 - Qualified personnel must inspect the system to make sure that it is adequate to take the maximum power used by the equipment shown on the equipment rating plate. In particular, make sure that the system cable cross section is adequate for the power absorbed by the unit.
 - No adaptors, multiple outlet sockets and/or extension cables are permitted to connect the unit to the electric mains.
 - An omnipolar switch shall be provided for connection to mains, as required by the current safety regulations.
 - The use of any power-operated component implies observance of a few basic rules, for example:
 - do not touch the unit with wet or damp parts of the body and/or with bare feet;
 - do not pull electric cables;
 - do not leave the equipment exposed to weather (rain, sun, etc.) unless expressly required to do so;
 - do not allow children or inexperienced persons to use equipment;
 - The unit input cable shall not be replaced by the user.
- In case of damage to the cable, switch off the unit and contact qualified personnel to replace.
- When the unit is out of use for some time the electric switch supplying all the power-driven components in the system (i.e. pumps, burner, etc.) should be switched off.

3b) FIRING WITH GAS, LIGHT OIL OR OTHER FUELS

GENERAL

- The burner shall be installed by qualified personnel and in compliance with regulations and provisions in force; wrong installation can cause injuries to people and animals, or damage to property, for which the manufacturer cannot be held liable.
- Before installation, it is recommended that all the fuel supply system pipes be carefully cleaned inside, to remove foreign matter that might impair the burner operation.
- Before the burner is commissioned, qualified personnel should inspect the following:
 - a the fuel supply system, for proper sealing;
 - b the fuel flow rate, to make sure that it has been set based on the firing rate required of the burner;
 - c the burner firing system, to make sure that it is supplied for the designed fuel type;
 - d the fuel supply pressure, to make sure that it is included in the range shown on the rating plate;
 - e the fuel supply system, to make sure that the system dimensions are adequate to the burner firing rate, and that the system is equipped with all the safety and control devices required by the regulations in force.
- When the burner is to remain idle for some time, the fuel supply tap or taps should be closed.

SPECIAL INSTRUCTIONS FOR USING GAS

Have qualified personnel inspect the installation to ensure that:

- a the gas delivery line and train are in compliance with the regulations and provisions in force;
 - b all gas connections are tight;
 - c the boiler room ventilation openings are such that they ensure the air supply flow required by the current regulations, and in any case are sufficient for proper combustion.
- Do not use gas pipes to earth electrical equipment.
 - Never leave the burner connected when not in use. Always shut the gas valve off.
 - In case of prolonged absence of the user, the main gas delivery valve to the burner should be shut off.

Precautions if you can smell gas

- a do not operate electric switches, the telephone, or any other item likely to generate sparks;
 - b immediately open doors and windows to create an air flow to purge the room;
 - c close the gas valves;
 - d contact qualified personnel.
- Do not obstruct the ventilation openings of the room where gas appliances are installed, to avoid dangerous conditions such as the development of toxic or explosive mixtures.

DIRECTIVES AND STANDARDS

Gas burners

European directives:

- Directive 2009/142/EC - Gas Appliances;
- Directive 2006/95/EC on low voltage;
- Directive 2004/108/EC on electromagnetic compatibility

Harmonised standards :

- UNI EN 676 (Gas Burners);
- CEI EN 60335-1(Household and similar electrical appliances - Safety. Part 1: General requirements;
- EN 50165 (Electrical equipment of non-electric appliances for household and similar purposes. Safety requirements.

Light oil burners

European directives:

- Directive 2006/95/EC on low voltage;
- Directive 2004/108/EC on electromagnetic compatibility

Harmonised standards :

- CEI EN 60335-1(Household and similar electrical appliances - Safety. Part 1: General requirements;
- EN 50165 (Electrical equipment of non-electric appliances for household and similar purposes. Safety requirements.

National standards :

- UNI 7824: Monobloc nebulizer burners for liquid fuels. Characteristics and test methods

Heavy oil burners

European directives:

- Directive 2006/95/EC on low voltage;
- Directive 2004/108/EC on electromagnetic compatibility

Harmonised standards :

- CEI EN 60335-1 Household and similar electrical appliances - SafetyPart 1: General requirements;
- EN 50165 Electrical equipment of non-electric appliances for household and similar purposes. Safety requirements.

National standards :

- UNI 7824: Monobloc nebulizer burners for liquid fuels. Characteristics and test methods

Gas - Light oil burners

European directives:

- Directive 2009/142/EC - Gas Appliances;
- Directive 2006/95/EC on low voltage;
- Directive 2004/108/EC on electromagnetic compatibility

Harmonised standards :

- UNI EN 676 Gas Burners
- CEI EN 60335-1(Household and similar electrical appliances - Safety. Part 1: General requirements;
- EN 50165 Electrical equipment of non-electric appliances for household and similar purposes. Safety requirements.

National standards :

- UNI 7824: Monobloc nebulizer burners for liquid fuels. Characteristics and test methods

Gas - Heavy oil burners

European directives:

- Directive 2009/142/EC - Gas Appliances;
- Directive 2006/95/EC on low voltage;
- Directive 2004/108/EC on electromagnetic compatibility

Harmonised standards :

- UNI EN 676 (Gas Burners);
- CEI EN 60335-1(Household and similar electrical appliances - Safety. Part 1: General requirements;
- EN 50165 Electrical equipment of non-electric appliances for household and similar purposes. Safety requirements.

National standards :

- UNI 7824: Monobloc nebulizer burners for liquid fuels. Characteristics and test methods

PART I: INSTALLATION MANUAL

Burner model identification

Burners are identified by burner type and model. Burner model identification is described as follows.

Type	Model	MD.	PR.	S.	*	A.	1.	80
(1)	(2)	(3)	(4)	(5)	(6)	(7)	(8)	(8)
(1) BURNER TYPE	KR1025 - KR1030 - KR1040							
(2) FUEL	N - Heavy oil, viscosity \leq 50cSt (7° E) @ 50° C E - Heavy oil, viscosity \leq 110cSt (15° E) @ 50° C D - Heavy oil, viscosity \leq 400cSt (50° E) @ 50° C P - Petroleum, viscosity 89cSt (12° E) @ 50° C							
(3) OPERATION Available versions	PR - Progressive MD - Fully modulating							
(4) BLAST TUBE	S - Standard							
(5) DESTINATION COUNTRY	* - see data plate							
(6) BURNER VERSION	A - Standard							
(7) EQUIPMENT	1 = 2 Gas valves + gas proving system 8 = 2 Gas valves + gas proving system + maximum gas pressure switch							
(8) GAS CONNECTION	65 = DN65 80 = DN80 100 = DN100 125 = DN125							

BURNERS		KR1025 2"	KR1025 DN65/80/100	KR1030 DN65	KR1030 DN80/100	KR1040
Output	min. - max. kW	2550 - 6700	2550 - 8700	2550 - 9500	2550 - 10600	2550 - 13000
Fuel		Natural gas - Heavy oil				
Category		(see next paragraph)				
Viscosity	°E @ 50 °C	See "Burner model identification" table				
Gas rate	min. - max. (Stm ³ /h)	270 - 709	270 - 921	270 - 1005	270 - 1122	270 - 1376
Gas pressure	min. - max. mbar	(Note2)				
Heavy oil rate	min. - max. kg/h	227 - 597	227 - 775	227 - 874	227 - 945	227 - 1160
Power supply		400V 3N ~ 50Hz				
Total power consumption (Heavy oil)	kW	71	71	76	76	84
Fan motor	kW	18.5	18.5	22	22	30
Pump motor	kW	4	4	5.5	5.5	5.5
Pre-heater resistors (heavy oil)	kW	24+24	24+24	24+24	24+24	24+24
Protection		IP40				
Operation		Progressive - Fully modulating				
Gas Train DN65	Valves size/ Gas connection	2" / Rp2	65 / DN65	65 / DN65	-	-
Gas Train DN80	Valves size/ Gas connection	-	80 / DN80	-	80 / DN80	80 / DN80
Gas Train DN100	Valves size/ Gas connection	-	100 / DN100	-	100 / DN100	100 / DN100
Gas Train DN125	Valves size/ Gas connection	-	-	-	-	125 / DN125
Operating temperature	°C	-10 ÷ +50				
Storage temperature	°C	-20 ÷ +60				
Working service*		Intermittent				

Note1:	All gas flow rates are referred to Stm ³ /h (1013 mbar absolute pressure, 15 °C temperature) and are valid for G20 gas (nett calorific value H _i = 34.02 MJ/Stm ³).
Note2:	Maximum gas pressure = 500mbar (with Siemens VGD.. gas valves / Dungs MBC.. gas valves) Minimum gas pressure = see gas curves.

* **NOTE ON THE BURNER WORKING SERVICE:** for safety reasons, one controlled shutdown must be performed every 24 hours of continuous operation.

NOTE: Choosing the nozzle for heavy oil, consider Hi equal to 40.43MJ/kg.

Country and usefulness gas categories

GAS CATEGORY	COUNTRY																								
	AT	ES	GR	SE	FI	IE	HU	IS	NO	CZ	DK	GB	IT	PT	CY	EE	LV	SI	MT	SK	BG	LT	RO	TR	CH
I _{2H}																									
I _{2E}	LU	PL	-	-	-	-	-	-	-	-	-	-	-	-	-	-	-	-	-	-	-	-	-	-	-
I _{2E(R)B}	BE	-	-	-	-	-	-	-	-	-	-	-	-	-	-	-	-	-	-	-	-	-	-	-	-
I _{2L}	NL	-	-	-	-	-	-	-	-	-	-	-	-	-	-	-	-	-	-	-	-	-	-	-	-
I _{2ELL}	DE	-	-	-	-	-	-	-	-	-	-	-	-	-	-	-	-	-	-	-	-	-	-	-	-
I _{2Er}	FR	-	-	-	-	-	-	-	-	-	-	-	-	-	-	-	-	-	-	-	-	-	-	-	-

Overall dimensions (mm)

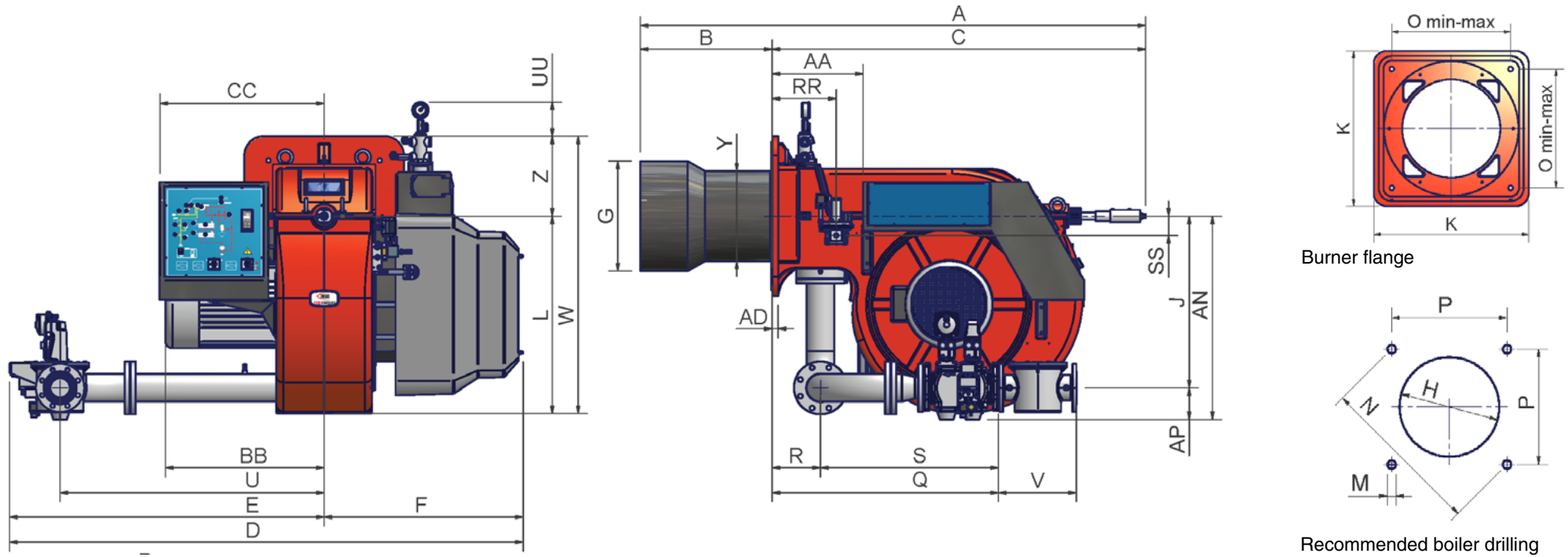

	DN*	A	AA	AD	AN	AP	B	BB	C	CC	D	E	F	G	H	J	K	L	M	N	O	P	Q	R	RR	S	SS	U	UU	V	W	Y	Z
KR1025	50	2088	377	25	809	100	544	641	1544	680	2142	1320	822	400	450	709	660	815	M16	651	460	460	1036	200	265	836	80	1092	142	216	1145	379	330
KR1025	65	2088	377	25	827	118	544	641	1544	680	2121	1299	822	400	450	709	660	815	M16	651	460	460	914	200	265	714	80	1092	142	292	1145	379	330
KR1025	80	2088	377	25	841	132	544	641	1544	680	2123	1301	822	400	450	709	660	815	M16	651	460	460	936	200	265	736	80	1092	142	322	1145	379	330
KR1025	100	2088	377	25	854	145	544	641	1544	680	2139	1317	822	400	450	709	660	815	M16	651	460	460	842	200	265	642	80	1092	142	382	1145	379	330
KR1030	65	2088	377	25	827	118	544	657	1544	680	2121	1299	822	454	504	709	660	815	M16	651	460	460	914	200	265	714	80	1092	142	292	1145	372	330
KR1030	80	2088	377	25	841	132	544	657	1544	680	2123	1301	822	454	504	709	660	815	M16	651	460	460	936	200	265	736	80	1092	142	322	1145	372	330
KR1030	100	2088	377	25	854	145	544	657	1544	680	2139	1317	822	454	504	709	660	815	M16	651	460	460	842	200	265	642	80	1092	142	382	1145	372	330
KR1040	80	2106	377	25	841	132	544	657	1562	680	2123	1301	822	514	564	709	660	815	M16	651	460	460	936	200	265	736	80	1192	142	322	1145	408	330
KR1040	100	2106	377	25	854	145	544	657	1562	680	2139	1317	822	514	564	709	660	815	M16	651	460	460	842	200	265	642	80	1192	142	382	1145	408	330
KR1040	125	2106	377	25	884	175	544	657	1562	680	2254	1432	822	514	564	709	660	815	M16	651	460	460	954	200	265	754	80	1192	142	480	1145	408	330

*DN = gas valves size

NOTE: the overall dimensions are referred to burners provided with Siemens VGD valves.

Performance curves

KR1025 2"

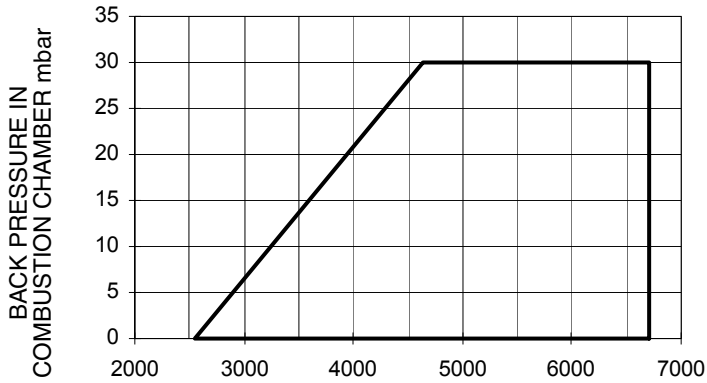

KR1025 DN65 - DN80 - DN100

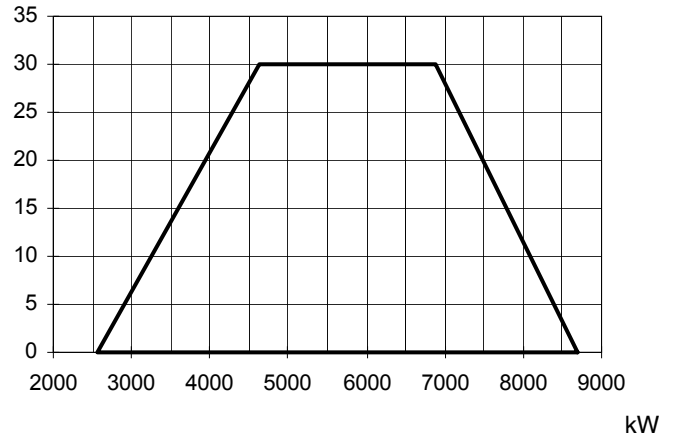

KR1030 DN65

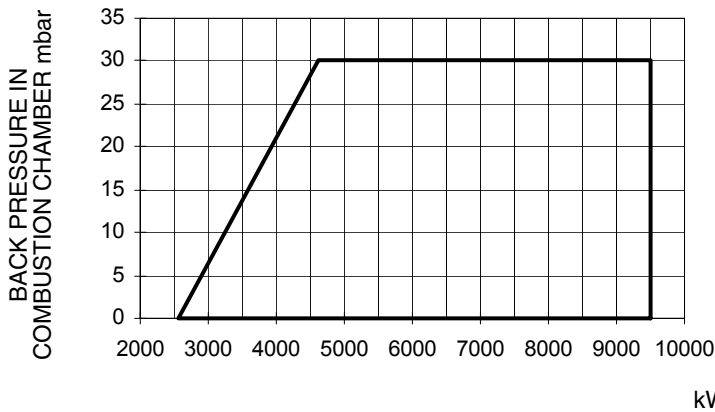

KR1030 DN80 - DN100

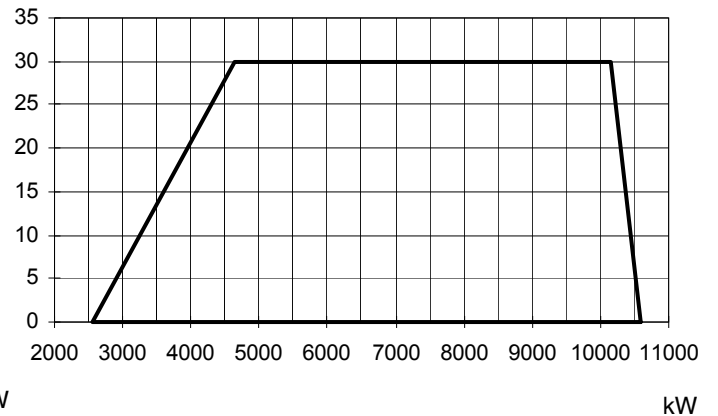

KR1040

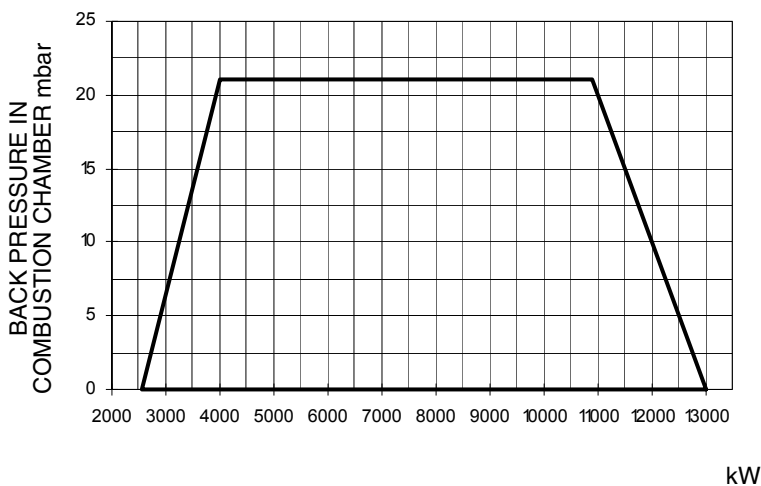

To get the input in kcal/h, multiply value in kW by 860.

Data are referred to standard conditions: atmospheric pressure at 1013mbar, ambient temperature at 15°C.

NOTE: The performance curve is a diagram that represents the burner performance in the type approval phase or in the laboratory tests, but does not represent the regulation range of the machine. On this diagram the maximum output point is usually reached by adjusting the combustion head to its "MAX" position (see paragraph "Adjusting the combustion head"); the minimum output point is reached setting the combustion head to its "MIN" position. During the first ignition, the combustion head is set in order to find a compromise between the burner output and the generator specifications, that is why the minimum output may be different from the Performance curve minimum.

Pressure in the network - gas rate curves

KR1025 2"

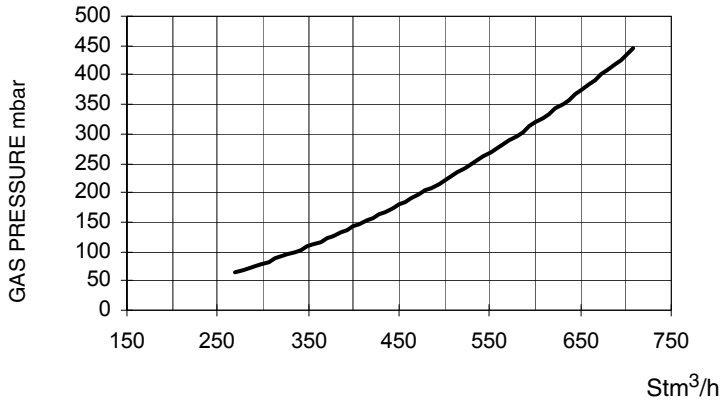

KR1025 DN65/80/100

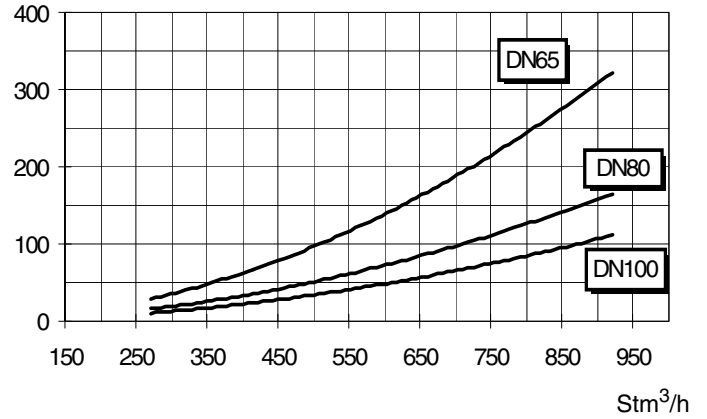

KR1030 DN65

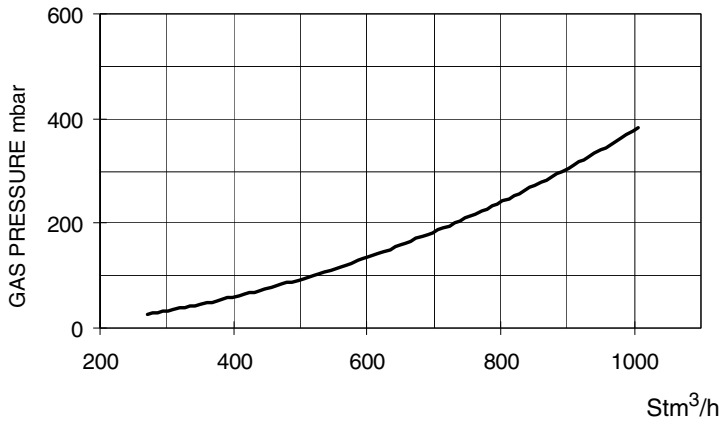

KR1030 DN80/100

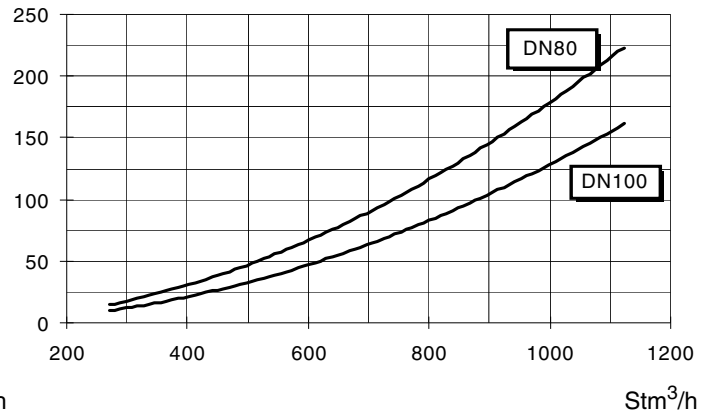

KR1040 DN80/100/125

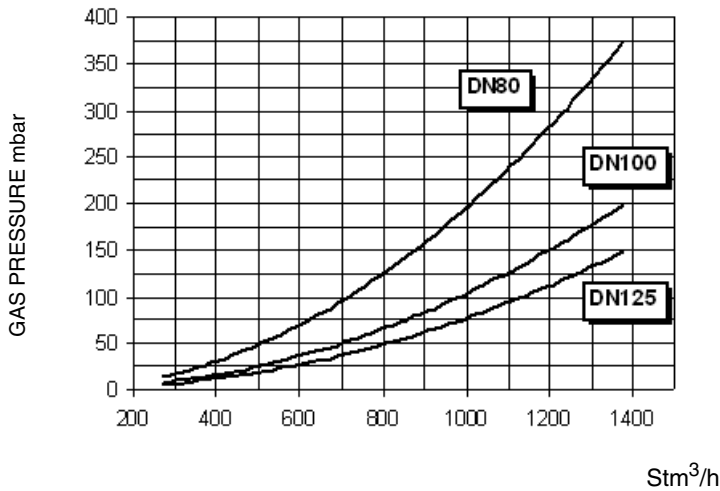

 Caution: the gas rate value is quoted on the x-axis, the related network pressure is quoted on the y-axis (pressure value in the combustion chamber is not included). To know the minimum pressure at the gas train inlet, necessary to get the requested gas rate, add the pressure value in the combustion chamber to the value read on the y-axis.

MOUNTINGS AND CONNECTIONS

Packing

The burners are despatched wooden cages whose dimensions:

Burner: 2270mm x 1720mm x 1360mm (L x P x H)

- burner with gas train detached;
- ceramic fibre plait to be inserted between the burner and the boiler;
- flexible oil pipes;
- oil filter;
- envelope containing this manual

Pumping unit: 1170mm x 870mm x 1610mm (L x P x H)

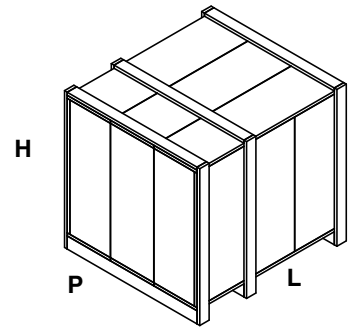

Packing cases of this kind are affected by humidity and are not suitable for stacking. The following are placed in each packing case:

To get rid of the burner's packing, follow the procedures laid down by current laws on disposal of materials.

Handling the burner

	<p>ATTENTION! the lifting and moving operations must be carried out by specialised and trained personnel. If these operations are not carried out perfectly, there is the residual risk of the burner to overturn and fall down.</p>
	<p>As for moving the burner, use means suited for the weight to sustain (see paragraph "Technical specifications").</p>

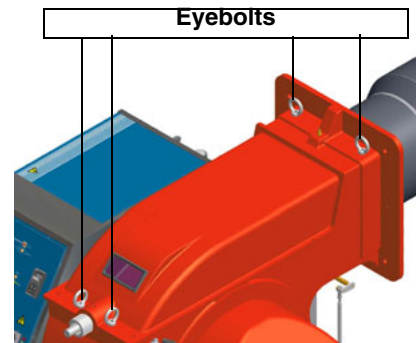

The burner is provided with eyebolts, for handling operations.

Fitting the burner to the boiler

To perform the installation, proceed as follows:

- 1 drill the furnace plate as described in paragraph ("Overall dimensions");
- 2 place the burner towards the furnace plate: lift and move the burner by means of its eyebolts placed on the top side (see "Lifting and moving the burner");
- 3 screw the stud bolts (5) in the plate holes, according to the burner's drilling plate described on paragraph "Overall dimensions";
- 4 place the gasket on the burner's flange;
- 5 install the burner into the boiler;
- 6 fix the burner to the stud bolts, by means of the fixing nuts, according to Fig. 1.
- 7 After fitting the burner to the boiler, ensure that the gap between the blast tube and the refractory lining is sealed with appropriate insulating material (ceramic fibre cord or refractory cement).

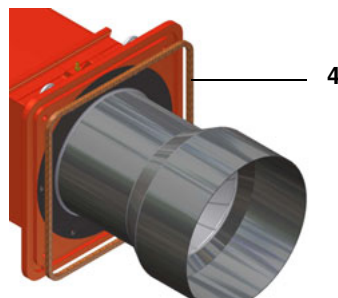
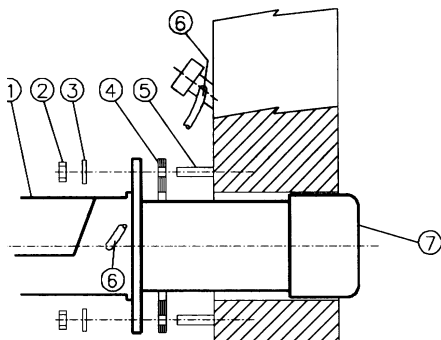

Keys

- 1 Burner
- 2 Fixing nut
- 3 Washer
- 4 Ceramic fibre plait
- 5 Stud bolt
- 7 Blast tube

Fig. 1

Set the upper side of the burner flange in a horizontal position, in order to obtain the correct inclination of the pre-heating tank.

Key

- 1 Burner flange (upper side indicated)
- 2 Bracket
- 3 Pre-heating tank on the burner

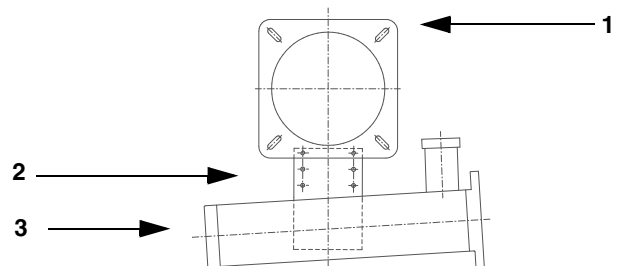

Matching the burner to the boiler

The burners described in this manual have been tested with combustion chambers that comply with EN676 regulation and whose dimensions are described in the diagram . In case the burner must be coupled with boilers with a combustion chamber smaller in diameter or shorter than those described in the diagram, please contact the supplier, to verify that a correct matching is possible, with respect of the application involved. To correctly match the burner to the boiler verify the necessary input and the pressure in combustion chamber are included in the burner performance curve; otherwise the choice of the burner must be revised consulting the burner manufacturer. To choose the blast tube lenght follow the instructions of the boiler manufacturer. In absence of these consider the following:

- Cast-iron boilers, three pass flue boilers (with the first pass in the rear part): the blast tube must protrude no more than 100 mm into the combustion chamber.
- Pressurised boilers with flame reversal: in this case the blast tube must penetrate at least 50 - 100 mm into combustion chamber in respect to the tube bundle plate.

The length of the blast tubes does not always allow this requirement to be met, and thus it may be necessary to use a suitably-sized spacer to move the burner backwards or to design a blast tube that suits the utilisation (please, contact the manufacturer).

Gas train connections

The diagrams show the components of the gas train included in the delivery and which must be fitted by the installer. The diagrams are in compliance with the current laws.

	ATTENTION: BEFORE EXECUTING THE CONNECTIONS TO THE GAS PIPE NETWORK, BE SURE THAT THE MANUAL CUTOFF VALVES ARE CLOSED. READ CAREFULLY THE "WARNINGS" CHAPTER AT THE BEGINNING OF THIS MANUAL.
--	--

Gas train - 1: Gas train with valves group VGD 20/40 with built-in gas pressure governor + VPS504 gas proving system

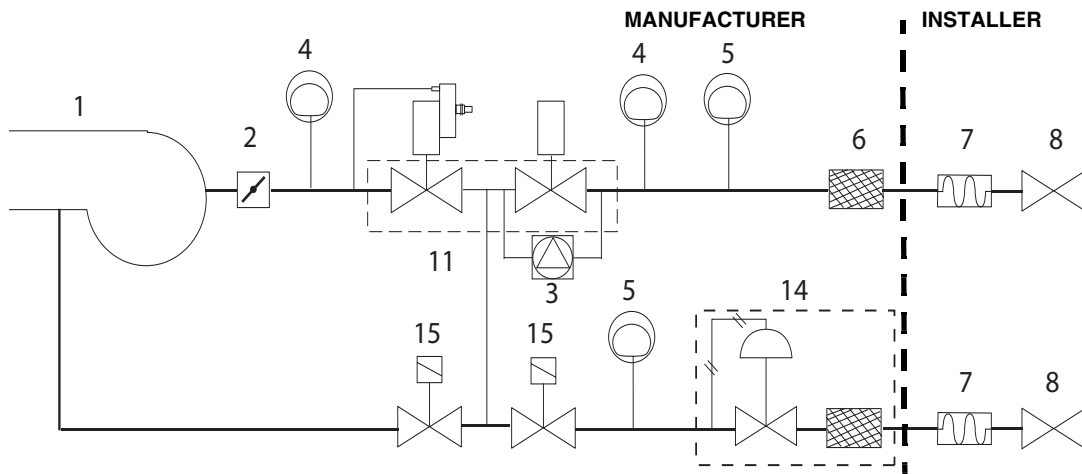

Gas train 3 (DN65/80/100): Gas train with valves group MBC 1900/3100/5000SE (2 valves + gas filter + pressure governor + pressure switch) + VPS504 gas proving system

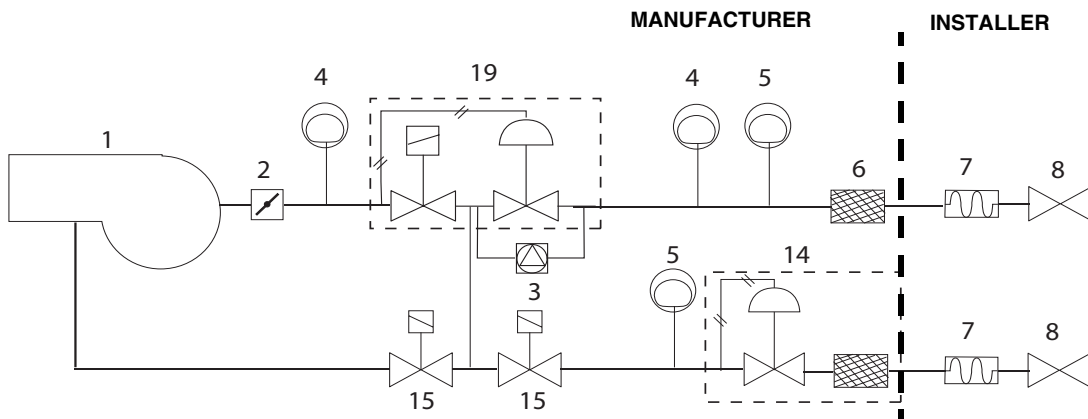

Gas train 3(DN125): Gas train with valves group VGD40 (2 valves + gas filter + pressure governor + pressure switch)+gas leakage pressure switch (PGCP)+Siemens LDU11/LMV + pilot gas train

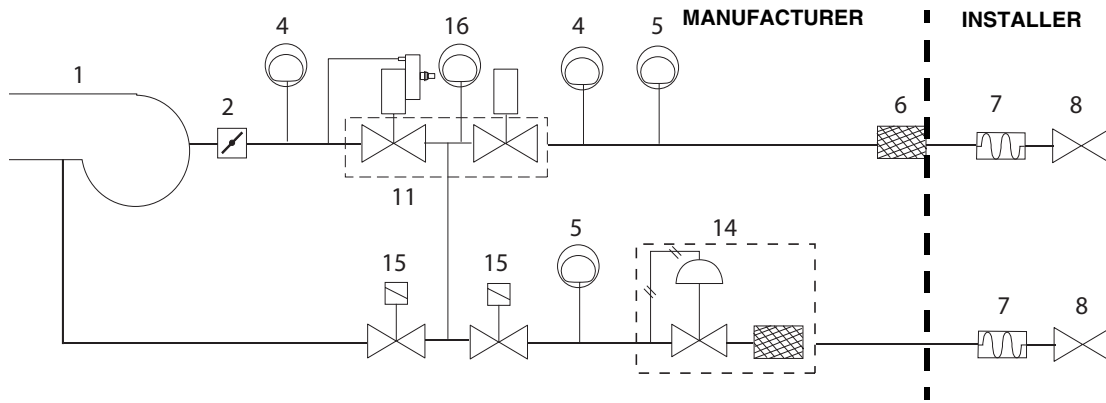

- | | |
|--|---|
| 1 Burner | 8 Manual cutoff valve |
| 2 Butterfly valve | 11 VGD Valves group |
| 3 Gas proving system | 14 Pressure governor with filter |
| 4 Maximum gas pressure switch (option) | 15 Pilot gas valve |
| 5 Minimum gas pressure switch | 18 MBC Valves group (2" with filter provided) |
| 6 Gas filter | 19 MBC Valves group (DN65/80/100) |
| 7 Bellow joint | |

* Note: the high gas pressure switch can be mounted either upstream or downstream the gas valve but upstream the butterfly gas valve (see item no.4 in the scheme above).

The pilot gas train is already installed to the burner, the following connections must be executed:

- connection from the filter with stabiliser to the gas supply network
- connection from the valve to the main gas train, by means of the pipe provided with the burner.

connection from the pilot gas train to the gas valves group of the main train



connection to the gas supply network



SIEMENS VGD40..

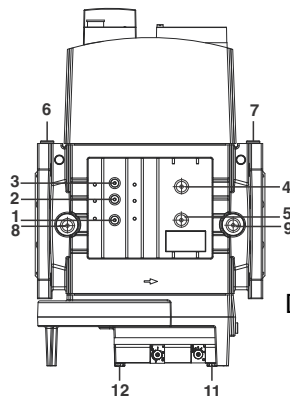

DUNGS MBC3100-5000SE

Fig. 2-pipe port (3) for connecting the pilot gas train to the valves group of the main gas train

Assembling the main gas grain

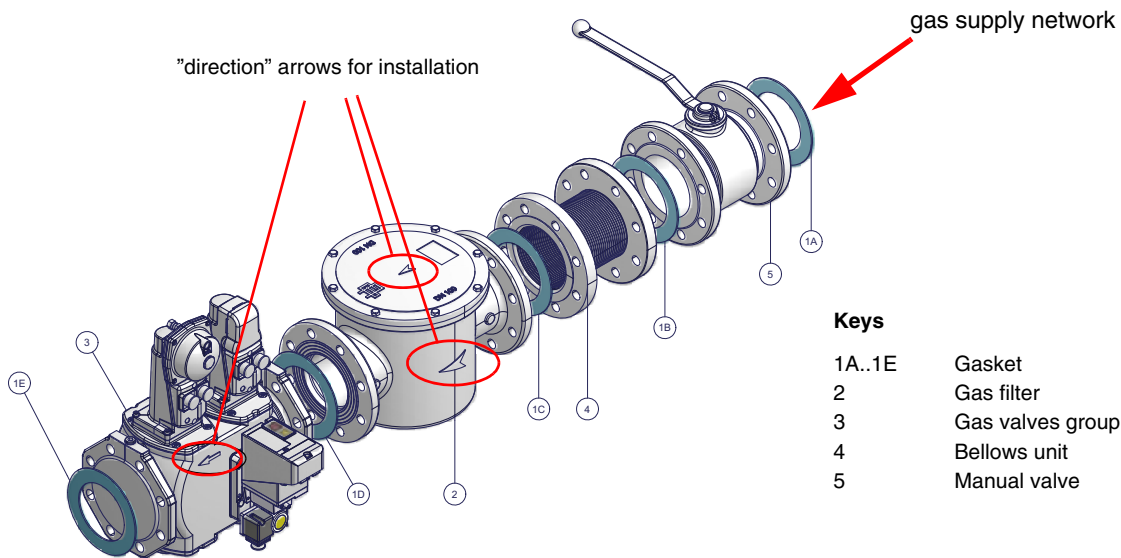

Fig. 3 - Example of gas train

To mount the gas train, proceed as follows:

1-a) in case of threaded joints: use proper seals according to the gas used;

1-b) in case of flanged joints: place a gasket (no. 1A..1E - Fig. 3) between the elements

NOTE: the bellows unit, the manual valve and the gaskets are not part of the standard supply.



ATTENTION: once the gas train is mounted according to the diagram on Fig. 3, the gas proving test must be performed, according to the procedure set by the laws in force.

The procedures of installation for the gas valves are shown in the next paragraphs, according to the gas train used:

- threaded gas trains with Multibloc Dungs MBC..SE 1200 or Siemens VGD20..
- flanged gas trains with Multibloc Dungs MBC..SE 1900-3100-5000 or Siemens VGD40..

MULTIBLOC DUNGS MBC1900-3100-5000SE (Flanged valves group)

Mounting

1. Insert setscrews A
2. Insert seals
3. Insert setscrews B
4. Tighten setscrews A + B.

Ensure correct seating of the seal!

6. After installation, perform leakage and functional test.

7. Disassembly in reverse order.

Mounting positions

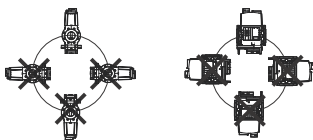

OPTION

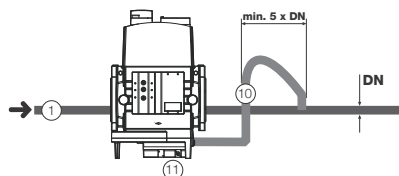

10 = pulse lines

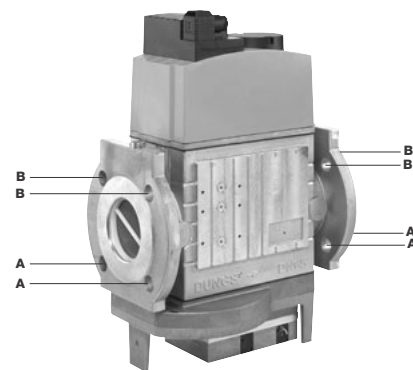

Fig. 4

Siemens VGD20.. and VGD40.. gas valves - with SKP2.. (pressure governor)

Mounting

- When mounting the VGD.. double gas valve, two flanges are required (as for VGD20.. model, the flanges are threaded);
- to prevent cuttings from falling inside the valve, first fit the flanges to the piping and then clean the associated parts;
- install the valve;
- the direction of gas flow must be in accordance with the direction of the arrow on the valve body;
- ensure that the bolts on the flanges are properly tightened;
- ensure that the connections with all components are tight;
- make certain that the O-rings and gaskets between the flanges and the double gas valve are fitted.

- Connect the reference gas pipe (TP in figure; 8mm-external size pipe supplied loose), to the gas pressure nipples placed on the gas pipe, downstream the gas valves: gas pressure must be measured at a distance that must be at least 5 times the pipe size. Leave the blowhole free (SA in figure). Should the spring fitted not permit satisfactory regulation, ask one of our service centres for a suitable replacement.

⚠ Caution: the SKP2 diaphragm D must be vertical (see Fig. 7).

⚠ WARNING: removing the four screws BS causes the device to be unserviceable!

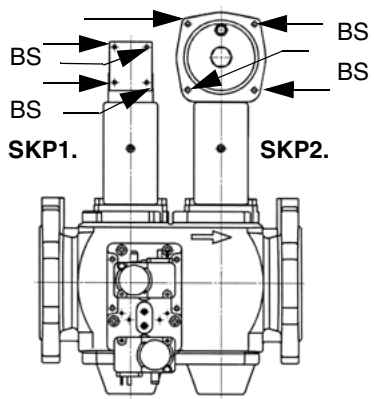

Fig. 5

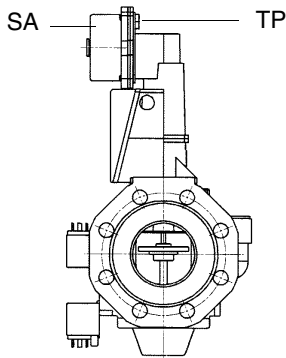

Fig. 6

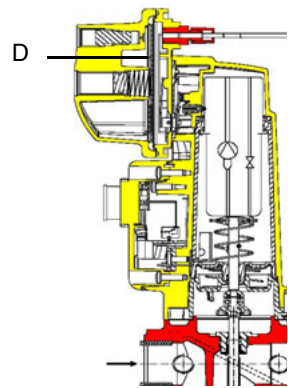

Fig. 7

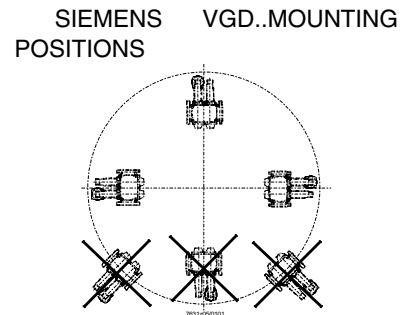

Fig. 8

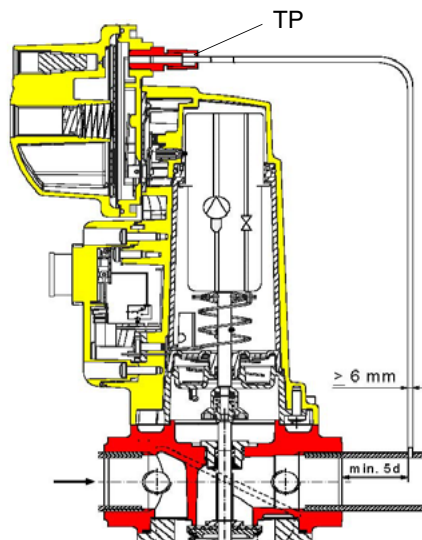
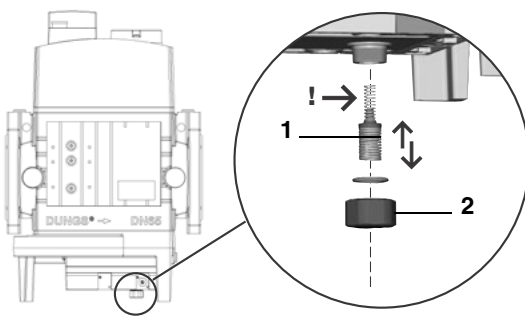

Fig. 9

Pressure adjusting range

The pressure adjusting range, downstream the gas valves group, changes according to the spring provided with the valve group.



DUNGS MBC..SE

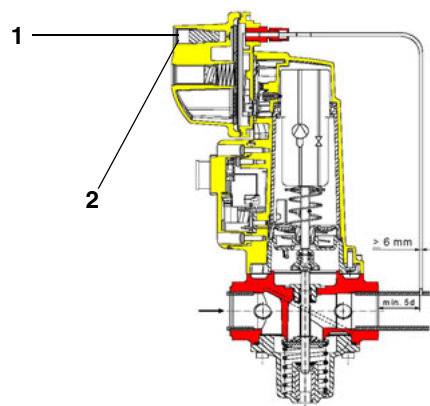

Siemens SKP actuator

- Keys**
 1 spring
 2 cap

DUNGS MBC valves:

Performance range (mbar)	4 - 20	20 - 40	40 - 80	80 - 150
Spring colour	-	ed	black	green

Siemens VGD valves with SKP actuator:

Performance range (mbar)	0 - 22	15 - 120	100 - 250
Spring colour	neutral	yellow	red

Once the train is installed, connect electrically all its elements: gas valves group, pressure switches, gas proving system.



ATTENTION: once the gas train is mounted according to the diagram on Fig. 3, the gas proving test must be performed, according to the procedure set by the laws in force.

Recommendations to design heavy oil feeding plants

This paragraph is intended to give some suggestions to make feeding plants for heavy oil burners. To get a regular burner operation, it is very important to design the supplying system properly. Here some suggestions will be mentioned to give a brief description.

The term "heavy oil" is generic and summarises several chemical-physical properties, above all viscosity. The excessive viscosity makes the oil impossible to be pumped, so it must be heated to let it flow in the pipeline; because of the low-boiling hydrocarbons and dissolved gases, the oil must be also pressurised. The pressurisation is also necessary to feed the burner pump avoiding its cavitation because of the high suction at the inlet. The supplying system scope is to pump and heat oil.

The oil viscosity is referred in various unit measures; the most common are: °E, cSt, Saybolt and Redwood scales. Table 3 shows the various unit conversions (e.g.: 132 cSt viscosity corresponds to 17.5°E viscosity). The diagram in Fig. 10 shows how the heavy oil viscosity changes according to its temperature.

Example: an oil with 22°E viscosity at 50°C once heated to 100°C gets a 3 °E viscosity. As far as the pumping capability, it depends on the type of the pump that pushes the oil even if on diagram in Fig. 10 a generic limit is quoted at about 100 °E, so it is recommended to refer to the specifications of the pump provided. Usually the oil minimum temperature at the oil pump inlet increases as viscosity does, in order to make the oil easy to pump. Referring to the diagram on Fig. 11, it is possible to realise that to pump an oil with 50°E viscosity at 50°C, it must be heated at about 80°C.

Pipe heating system

Pipe heating system must be provided, that is a system to heat pipes and plant components to maintain the viscosity in the pumping limits. Higher the oil viscosity and lower the ambient temperature, more necessary the pipe heating system.

Inlet minimum pressure of the pump (both for supplying system and burner)

A very low pressure leads to cavitation (signalled by its peculiar noise): the pump manufacturer declares the minimum value. Therefore, check the pump technical sheets. By increasing the oil temperature, also the minimum inlet pressure at the pump must increase, to avoid the gassification of the oil low-boiling products and the cavitation. The cavitation compromises the burner operation, it causes the pump to break too. The diagram on Fig. 12 roughly shows the inlet pump pressure according to the oil temperature.

Pump operating maximum pressure (both for the supplying system and burner)

Remember that pumps and all the system components through which the oil circulates, feature an upper limit. Always read the technical documentation for each component. Schemes on Fig. 14 and Fig. 15 are taken from UNI 9248 "liquid fuel feeding lines from tank to burner" standard and show how a feeding line should be designed. For other countries, see related laws in force. The pipe dimensioning, the execution and the winding dimensioning and other constructive details must be provided by the installer.

Adjusting the supplying oil ring

According to the heavy oil viscosity used, in the table below indicative temperature and pressure values to be set are shown.

Note: the temperature and pressure range allowed by the supplying ring components must be checked in the specifications table of the components themselves.

HEAVY OIL VISCOSITY AT 50 °C		PIPELINE PRESSURE	PIPELINE TEMPERATURE
cSt (°E)		bar	°C
	< 50 (7)	1- 2	20
> 50 (7)	< 110 (15)	1- 2	50
> 110 (15)	< 400 (50)	1- 2	65

Tab. 1

Burner adjustments

The table below shows indicative values of temperature and pressure to be set on the burner devices, according to the viscosity of the heavy oil used. The oil temperature should be set on TR resistor thermostat in order to get about 1.5°E viscosity at the nozzle.

VISCOSITY AT 50 °C		NOZZLE PRESSURE MEASURED IN THE GUN	RETURN NOZZLE PRESSURE		TEMPERATURE ON THE PRE-HEATING RESISTORS		TEMPERATURE OF THE RESISTORS SAFETY THERMOSTAT TRS	TEMPERATURE ON THE OIL ENABLING THERMOSTAT TCN	TEMPERATURE ON THE PLANT ENABLING THERMOSTAT TCI
			min.	max.	min.	max.			
cSt (°E)		bar	bar		°C		°C	°C	°C
	< 50 (7)	25	7-9	19-20	100	115	170	80	50 - 60
> 50 (7)	< 110 (15)	25	7-9	19-20	125	140	190	100	60 - 80
> 110 (15)	400 (50)	25	7-9	19-20	145	160	190	110	70 - 90

Tab. 2

Viscosity units conversion table

Cinematics viscosity Centistokes (cSt)	Engler Degrees (°E)	Saybolt Seconds Universal (SSU)	Saybolt Seconds Furol (SSF)	Redwood Seconds no.1 (Standard)	Redwood Seconds no..2 (Admiralty)
1	1	31	--	29	--
2.56	1.16	35	--	32.1	--
4.3	1.31	40	--	36.2	5.1
7.4	1.58	50	--	44.3	5.83
10.3	1.88	60	--	52.3	6.77
13.1	2.17	70	12.95	60.9	7.6
15.7	2.45	80	13.7	69.2	8.44
18.2	2.73	90	14.44	77.6	9.3
20.6	3.02	100	15.24	85.6	10.12
32.1	4.48	150	19.3	128	14.48
43.2	5.92	200	23.5	170	18.9
54	7.35	250	28	212	23.45
65	8.79	300	32.5	254	28
87.6	11.7	400	41.9	338	37.1
110	14.6	500	51.6	423	46.2
132	17.5	600	61.4	508	55.4
154	20.45	700	71.1	592	64.6
176	23.35	800	81	677	73.8
198	26.3	900	91	762	83
220	29.2	1000	100.7	896	92.1
330	43.8	1500	150	1270	138.2
440	58.4	2000	200	1690	184.2
550	73	2500	250	2120	230
660	87.6	3000	300	2540	276
880	117	4000	400	3380	368
1100	146	5000	500	4230	461
1320	175	6000	600	5080	553
1540	204.5	7000	700	5920	645
1760	233.5	8000	800	6770	737
1980	263	9000	900	7620	829
2200	292	10000	1000	8460	921
3300	438	15000	1500	13700	--
4400	584	20000	2000	18400	--

Tab. 3

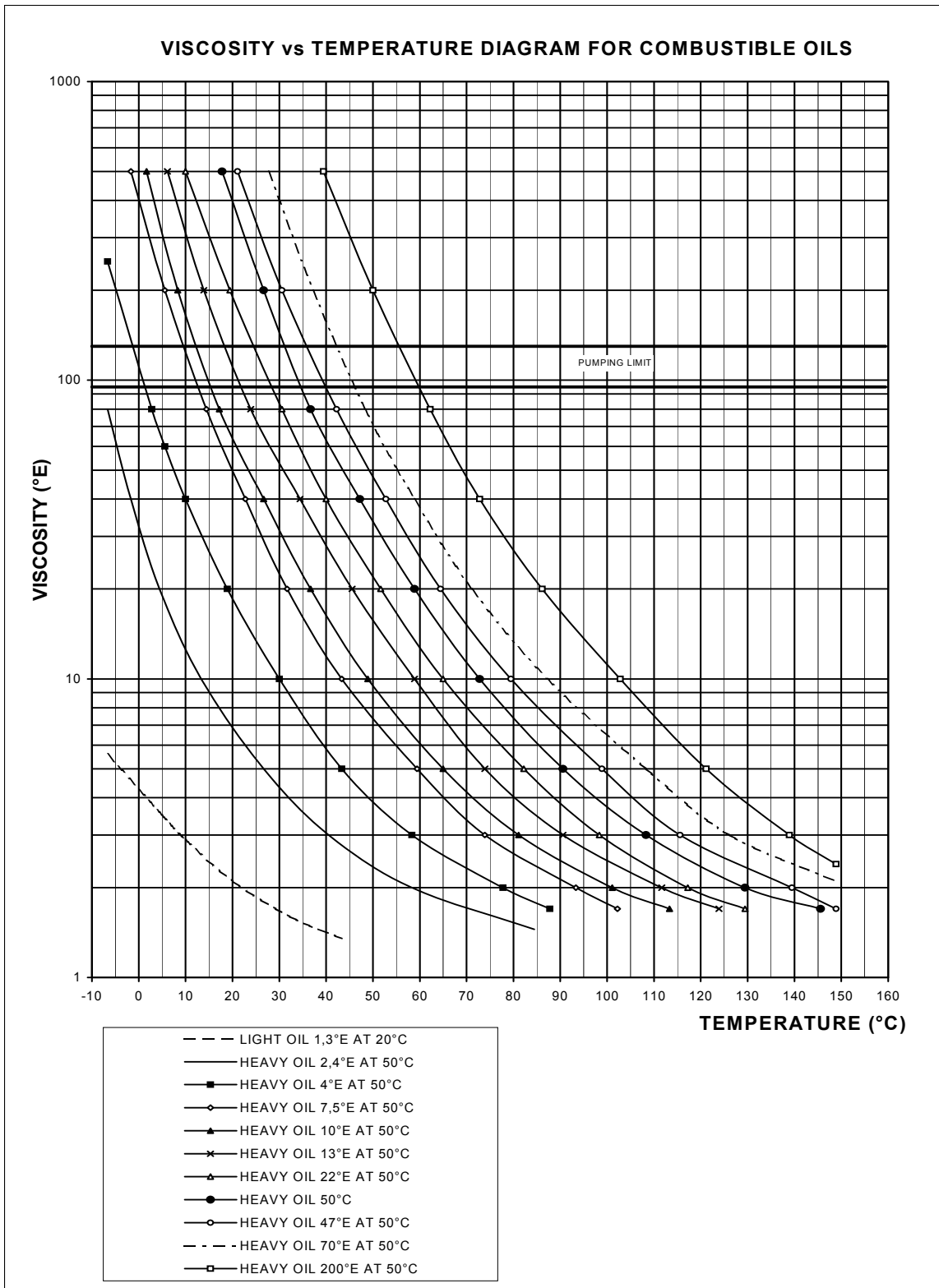

Fig. 10

Indicative diagram showing the oil temperature at burner pump inlet vs. oil viscosity

Example: if the oil has a 50°E @ 50°C viscosity, the oil temperature at the pump inlet should be 80°C (see diagram).

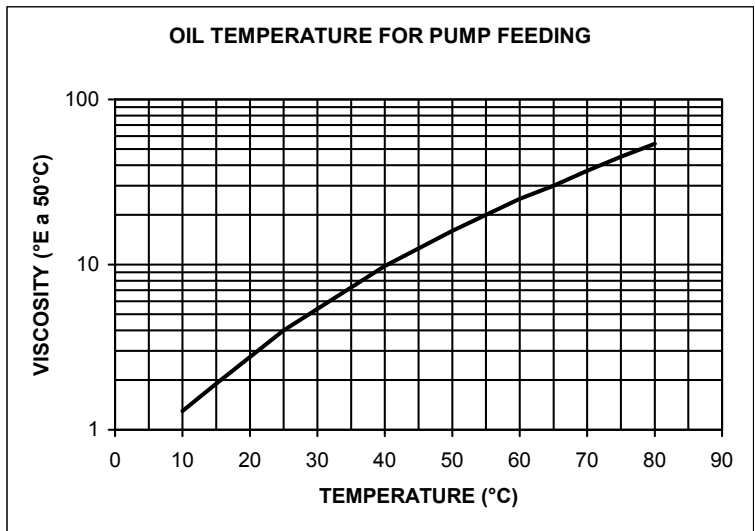

Fig. 11

Indicative diagram showing the oil pressure according to its temperature

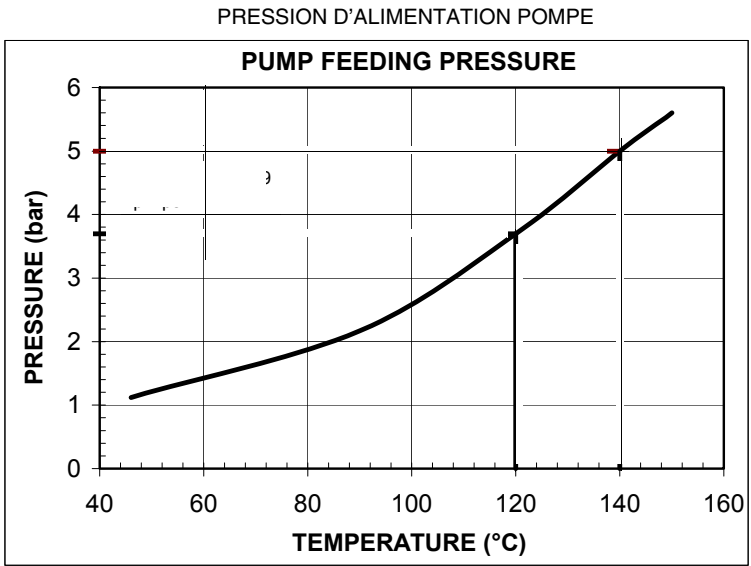

Fig. 12

Indicative diagram showing the oil atomising temperature according to its viscosity

Example: if the oil has a 50°E @ 50°C viscosity, the oil atomising temperature should be between 145°C and 160°C (see diagram).

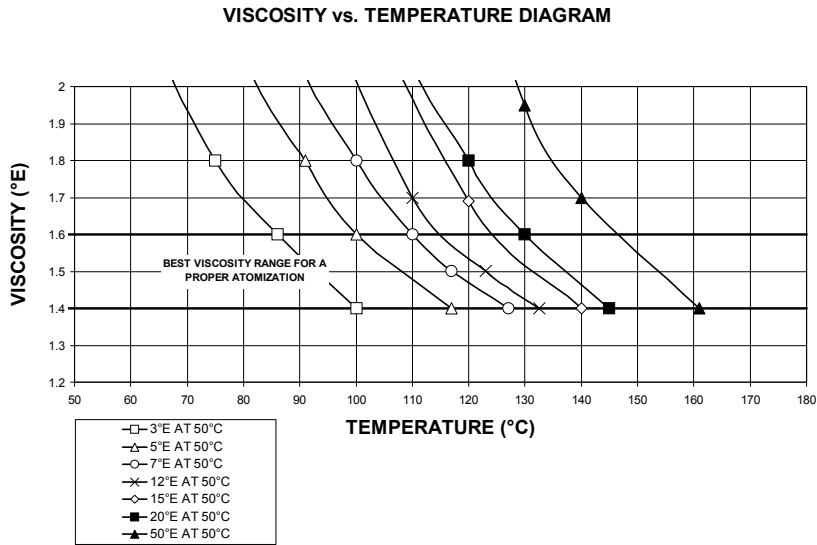

Fig. 13

Hydraulic Diagram 3ID0014

- 1 Main tank
- 2 Bottom valve
- 3 Main tank pre-heating pipe
- 4 Oil filter (filtration, 1mm)
- 5 Circuit pressure regulator
- 6 Manometer
- 7 Pressure regulation by-pass valve
- 8 Manual valve
- 9 Oil pump
- 10 Pump pressure regulator
- 11 Unidirectional valve
- 12 Service tank pre-heating resistor
- 13 Service tank pre-heating thermostat
- 14 Burner consent thermostat
- 15 Thermometer
- 16 Consent pressure switch for service tank resistor
- 17 Service tank heating pipe
- 18 Service tank air drain valve
- 19 Service tank
- 20 Oil filter
- 21 Fuel solenoid valve
- 22 Fuel valve
- 23 Burner pump flexible hoses
- 24 Burner oil pump
- 25 Pre-heating tank resistor
- 26 Pre heating tank
- 27 Oil consent thermostat
- 28 Heather safety thermostat
- 29 Thermostat for oil temperature setting
- 30 Tank filter
- 31 Thermometer
- 32 Check valve
- 33 Return pressure governor
- 35 Oil needle drive piston
- 36 Oil rate regulator
- 37 Burner consent thermostat
- 42 Burner start consent thermostat
- 43 Burner
- 45 Thermostat for pipes pre-heating pumps
- 46 Water pump for service tank pre-heating (1)
- 47 Water pump for main tank pre-heating (19)
- 48 Water pre-heating balance setting valve
- 50 Oil circulation pump
- 52 Oil ring max. pressure switch

Hydraulic Diagram 3ID0023

- 1 Main tank
- 2 Bottom valve
- 3 Main tank pre-heating pipe
- 4 Oil filter
- 5 Circuit pressure regulator
- 6 Manometer
- 7 Pressure regulation by-pass valve
- 8 Manual valve
- 9 Oil pump
- 10 Pump pressure regulator
- 11 Unidirectional valve
- 12 Service tank pre-heating resistor
- 13 Service tank pre-heating thermostat
- 14 Burner consent thermostat
- 15 Thermometer
- 16 Consent pressure switch for service tank resistor
- 17 Service tank heating pipe
- 18 Service tank air drain valve
- 19 Service tank
- 20 Oil filter
- 21 Fuel solenoid valve
- 22 Fuel valve
- 23 Burner pump flexible hoses
- 24 Burner oil pump
- 25 Pre-heating tank resistor
- 26 Pre heating tank
- 27 Oil consent thermostat
- 28 Pre-heating tank resistors safety thermostat
- 29 Thermostat for oil temperature setting
- 30 Pre-heating tank filter
- 31 Thermometer
- 32 Check valve
- 33 Return pressure governor
- 35 Oil needle drive piston
- 36 Three way valve for piston drive
- 37 Burner consent thermostat
- 42 Air separation bottle
- 43 Burner
- 45 Thermostat for pipes pre-heating pumps
- 46 Water pump for service tank pre-heating (1)
- 47 Water pump for main tank pre-heating (19)
- 48 Valves for setting of pre-heating water balance
- 52 Oil ring max. pressure switch

Hydraulic system

The pumps that are used can be installed both into single-pipe and double-pipe systems.

Single-pipe system: a single pipe drives the oil from the tank to the pump's inlet. Then, from the pump, the pressurised oil is driven to the nozzle: a part comes out from the nozzle while the other part goes back to the pump. In this system, the by-pass plug, if provided, must be removed and the optional return port, on the pump's body, must be sealed by steel plug and washer.

Double-pipe system: as for the single pipe system, a pipe that connects the tank to the pump's inlet is used besides another pipe that connects the pump's return port to the tank, as well. The excess of oil goes back to the tank: this installation can be considered self-bleeding. If provided, the inside by-pass plug must be installed to avoid air and fuel passing through the pump.

Burners come out from the factory provided for double-stage systems. They can be suited for single-pipe system (recommended in the case of gravity feed) as described before. To change from a 1-pipe system to a 2-pipe-system, insert the by-pass plug **G** (as for ccw-rotation- referring to the pump shaft).

Caution: Changing the direction of rotation, all connections on top and side are reversed.

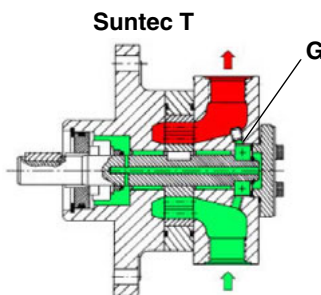

Bleed

Bleeding in two-pipe operation is automatic : it is assured by a bleed flat on the piston. In one-pipe operation, the plug of a pressure gauge port must be loosened until the air is evacuated from the system.

About the use of fuel pumps

- Make sure that the by-pass plug is not used in a single pipe installation, because the fuel unit will not function properly and damage to the pump and burner motor could result.
- Do not use fuel with additives to avoid the possible formation over time of compounds which may deposit between the gear teeth, thus obstructing them.
- After filling the tank, wait before starting the burner. This will give any suspended impurities time to deposit on the bottom of the tank, thus avoiding the possibility that they might be sucked into the pump.
- On initial commissioning a "dry" operation is foreseen for a considerable length of time (for example, when there is a long suction line to bleed). To avoid damages inject some lubrication oil into the vacuum inlet.
- Care must be taken when installing the pump not to force the pump shaft along its axis or laterally to avoid excessive wear on the joint, noise and overloading the gears.
- Pipes should not contain air pockets. Rapid attachment joint should therefore be avoided and threaded or mechanical seal junctions preferred. Junction threads, elbow joints and couplings should be sealed with removable sg component. The number of junctions should be kept to a minimum as they are a possible source of leakage.
- Do not use PTFE tape on the suction and return line pipes to avoid the possibility that particles enter circulation. These could deposit on the pump filter or the nozzle, reducing efficiency. Always use O-Rings or mechanical seal (copper or aluminium gaskets) junctions if possible.
- An external filter should always be installed in the suction line upstream of the fuel unit.

Oil pumps

Suntec T..	
Viscosity	3 - 75 cSt
Oil temperature	0 - 150 °C
Minimum suction pressure	- 0.45 bar to prevent gasing
Maximum suction pressure	5 bar
Rated speed	3600 rpm max.

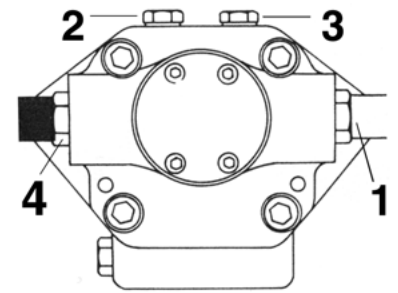

Key

- 1 Inlet G3/4
- 2 Pressure gauge port G1/4
- 3 Vacuum gauge port to measure the inlet vacuum G1/4
- 4 To pressure adjusting valve G3/4

"Note: pump with "C" rotation.

Suntec TV Pressure governor

Pressure adjustment

Remove cap-nut 1 and the gasket 2, unscrew the lock nut 4. To increase pressure, twist adjusting screw 3 clockwise.

To decrease the pressure, twist screw counterclockwise. Tight the lock nut 4, refit the gasket 2 and the cap nut 1.

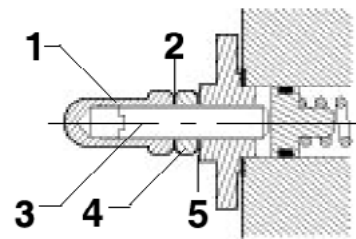

Key

- 1 Cap nut
- 2 Gasket
- 3 Adjusting screw
- 4 Lock nut
- 5 Gasket

Fig. 16

Connections to the oil gun

- 1 Inlet (C)
- 2 Return (B)
- 3 Lance opening (A)
- 4 Heating wire (only for high density oil burners)
- 5 Cartridge-type heater (only for Ecoden or heavy oil burners)

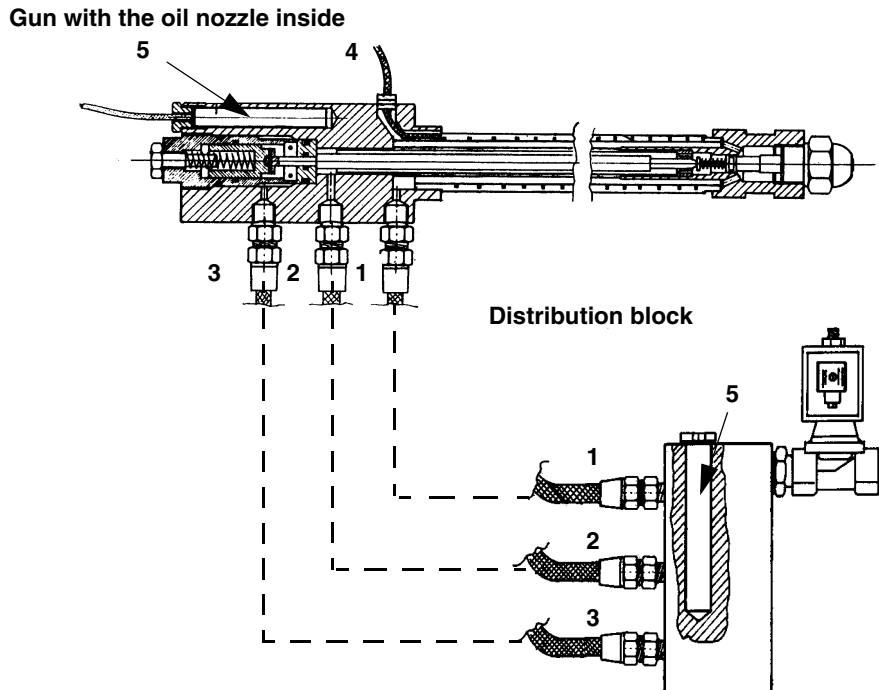

Connecting the burner to the oil pumping unit

Follow the scheme in the picture below to connect the burner to the oil pumping unit. The pump sends the oil coming from the tank to the burner. The pressure governor makes the oil reach the nozzle at the required pressure, while the excess of oil goes back to the tank. To change the delivery pressure act on the adjusting screw of the delivery pressure governor.

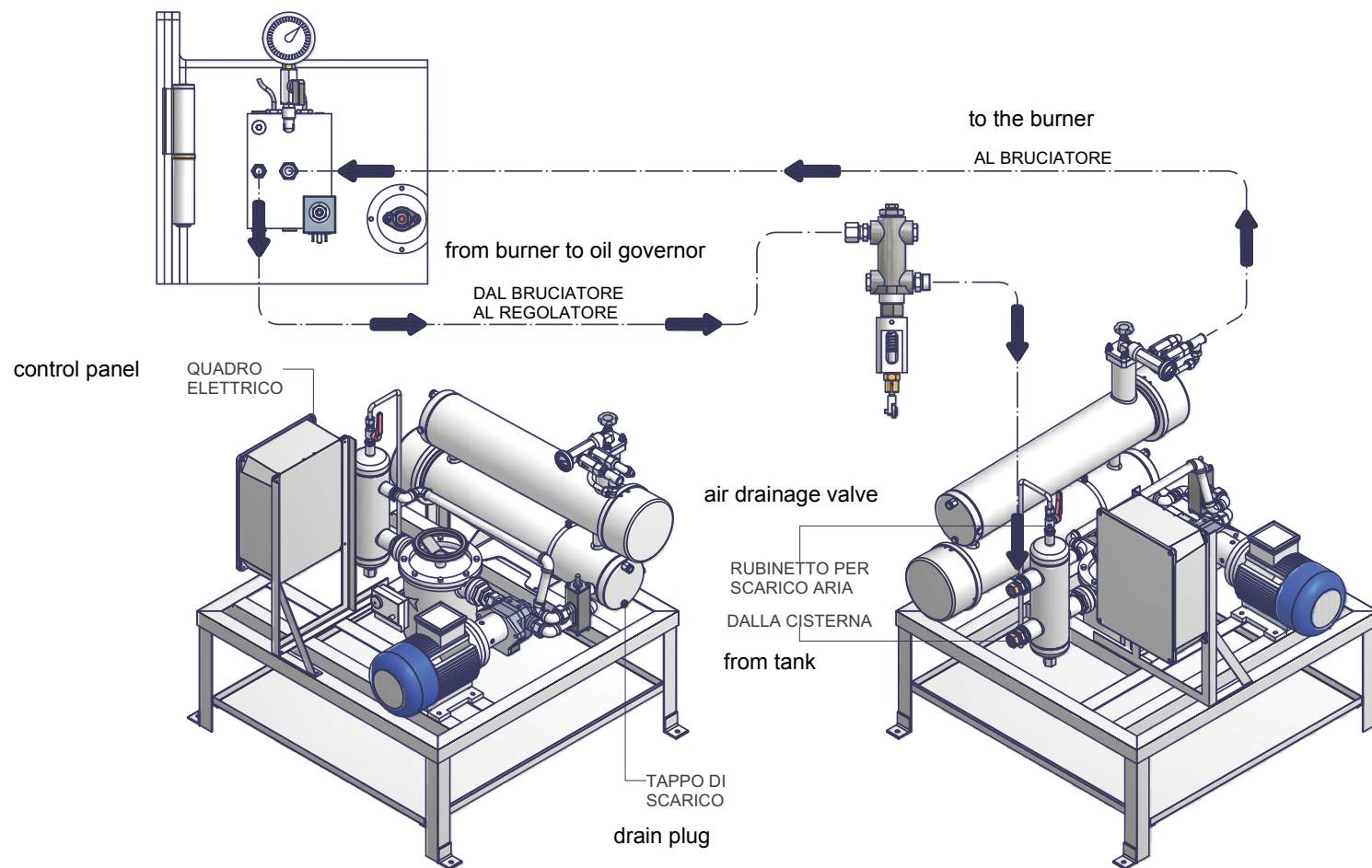

CAUTION: caps are not sealing type but used for shipment only. The flexible hoses between the pump and the burner are the ones called (on the label) "Oil high pressure flexible hose". The flexible hose called "Oil low pressure flexible hose" is the one to be connected upstream the oil filter.

Electrical connections

	<p>Respect the basic safety rules. make sure of the connection to the earthing system. do not reverse the phase and neutral connections. fit a differential thermal magnet switch adequate for connection to the mains.</p>
	<p>ATTENTION: before executing the electrical connections, pay attention to turn the plant's switch to OFF and be sure that the burner's main switch is in 0 position (OFF) too. Read carefully the chapter "WARNINGS", and the "Electrical connections" section.</p>

- Remove the cover of the electrical board mounted on the burner.
- Execute the electrical connections to the power supply terminal board as shown here following, check the direction of rotation of the fan motor and pump motor (see next paragraph) and refit the electrical board cover.

	<p>WARNING: The burner is provided with a jumper between terminals 6 and 7; in the event of connecting the high/low flame thermostat remove this jumper before connecting the thermostat.</p>
	<p>IMPORTANT: while connecting electric supply wires to burner's terminal block be sure that ground wire should be longer than phase and neutral ones.</p>

As for a complete description of electrical diagrams, see "Electrical wiring diagrams".

Connecting the oil heating resistors

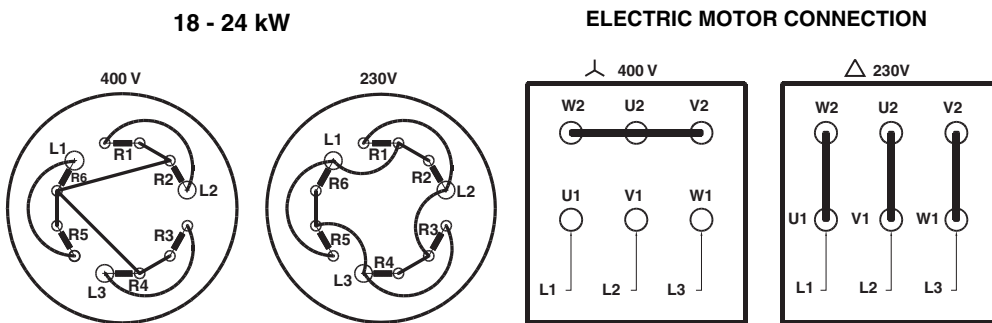

Rotation of fan motor and pump motor

Once the electrical connection of the burner is executed, remember to check the rotation of the motor. The motor should rotate according to the indication on the body. In the event of wrong rotation, reverse the three-phase supply and check again the rotation of the motor.

	<p>CAUTION: adjust the thermal cut-out according to the motor rated current value.</p>
---	---

ADJUSTMENTS

Oil thermostat adjustment

To find the thermostats, remove the cover of the burner switchboard. Adjust them using a screwdriver on the VR screw as shown in the next picture.

NOTE: thermostat **TCI** is provided on burners fired with fuel oil having a 50° E at 50° C viscosity only.

TCN - Oil enabling thermostat (Fig. 17)

Adjust this thermostat to a value 10% lower than that shown in the viscosity-temperature diagram (Fig. 10).

TRS - Resistor safety thermostat (Fig. 17)

The thermostat is set during factory testing at about 190° C.

This thermostat trips when the operating temperature exceeds the set limit. Ascertain the cause of the malfunction and reset the thermostat by means of the PR button.

TR - Resistor thermostat (Fig. 17)

Adjust this thermostat to the correct value according to the viscosity-temperature diagram (Fig. 10) and check the temperature by using a thermometer with a scale of up to 200° C mounted on the pre-heating tank.

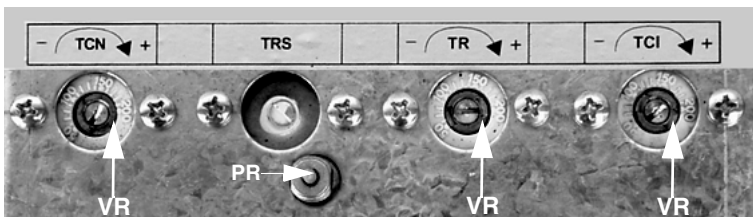

Fig. 17

TCI - Plant enabling thermostat (Fig. 17)

This thermostat is fitted on burners fired with oil at a viscosity of 50° E at 50° C only. Set the thermostat according to the data shown on page 15.

Thermostat adjustment for petroleum burners

To find the thermostats, remove the burner switchboard cover. Adjust them using a screwdriver on the VR screw as shown in the next picture.

TCI - Installation enabling thermostat

Set this thermostat to about 40° C.

TCN - Oil enabling thermostat

Adjust this thermostat to a value between 45 and 50°C. Anyway, set TCN to a value possibly lower than the one set for TR (see below).

TR - Resistor thermostat

Adjust this thermostat to a value between 45 and 50°C. Check the temperature by using a thermometer mounted on the pre-heating tank.

TRS - Resistor safety thermostat

The thermostat is set during factory testing at about 190° C.

This thermostat trips when the operating temperature exceeds the set limit. Ascertain the cause of the malfunction and reset the thermostat by means of the PR button (see picture).

CAUTION: even if the adjusting ranges for the TR (Resistor thermostat) and TCN (Oil enabling thermostat) are the same, set TCN to a value lower than the one set for TR.

Adjusting air and gas flow rates

	ATTENTION: before starting the burner up, be sure that the manual cutoff valves are open and check that the pressure upstream the gas train complies the value quoted on paragraph "Technical specifications". Be sure that the mains switch is closed.
	ATTENTION: During commissioning operations, do not let the burner operate with insufficient air flow (danger of formation of carbon monoxide); if this should happen, make the fuel decrease slowly until the normal combustion values are achieved.
	WARNING: NEVER LOOSE THE SEALED SCREWS! OTHERWISE, THE DEVICE WARRANTY WILL BE INVALIDATE!

	IMPORTANT! the combustion air excess must be adjusted according to the in the following chart.
---	---

Recommended combustion parameters		
<i>Fuel</i>	<i>Recommended (%) CO₂</i>	<i>Recommended (%) O₂</i>
Natural gas	9 ÷ 10	3 ÷ 4.8
Heavy oil	11 ÷ 12	4.2 ÷ 6.2

Combustion head gas pressure curves depending on the flow rate

Curves are referred to pressure = 0mbar in the combustion head!

The curves referred to the gas pressure in the combustion head, depending on the gas flow rate, are referred to the burner properly adjusted (percentage of residual O₂ in the flues as shown in the "Recommended combustion values" table and CO in the standard limits). During this stage, the combustion head, the gas butterfly valve and the actuator are at the maximum opening. Refer to Fig. 18, showing the correct way to measure the gas pressure, considering the values of pressure in combustion chamber, surveyed by means of the pressure gauge or taken from the boiler's Technical specifications.

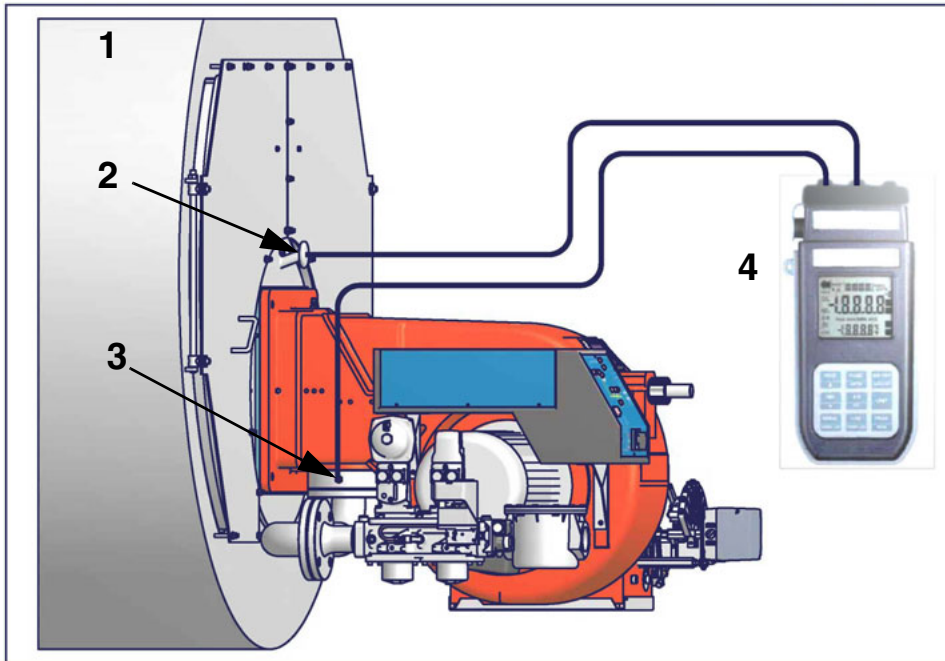

Fig. 18

Key

- 1 Generator
- 2 Pressure outlet on the combustion chamber
- 3 Gas pressure outlet on the butterfly valve
- 4 Differential pressure gauge

Measuring the gas pressure in the combustion head

In order to measure the pressure in the combustion head, insert the pressure gauge probes: one into the combustion chamber's pressure outlet (Fig. 18-2) to get the pressure in the combustion chamber and the other one into the butterfly valve's pressure outlet of the burner (Fig. 18-3). On the basis of the measured differential pressure, it is possible to get the maximum flow rate: in the pressure - rate curves (showed on the next paragraph), it is easy to find out the burner's output in Stm³/h (quoted on the x axis) from the pressure measured in the combustion head (quoted on the y axis). The data obtained must be considered when adjusting the gas flow rate.

NOTE: THE PRESSURE-RATE CURVES ARE GIVEN AS INFORMATION ONLY; FOR A PROPER SETTING OF THE GAS RATE, PLEASE REFER TO THE GAS METER READING.

Pressure in combustion head - gas rate curves

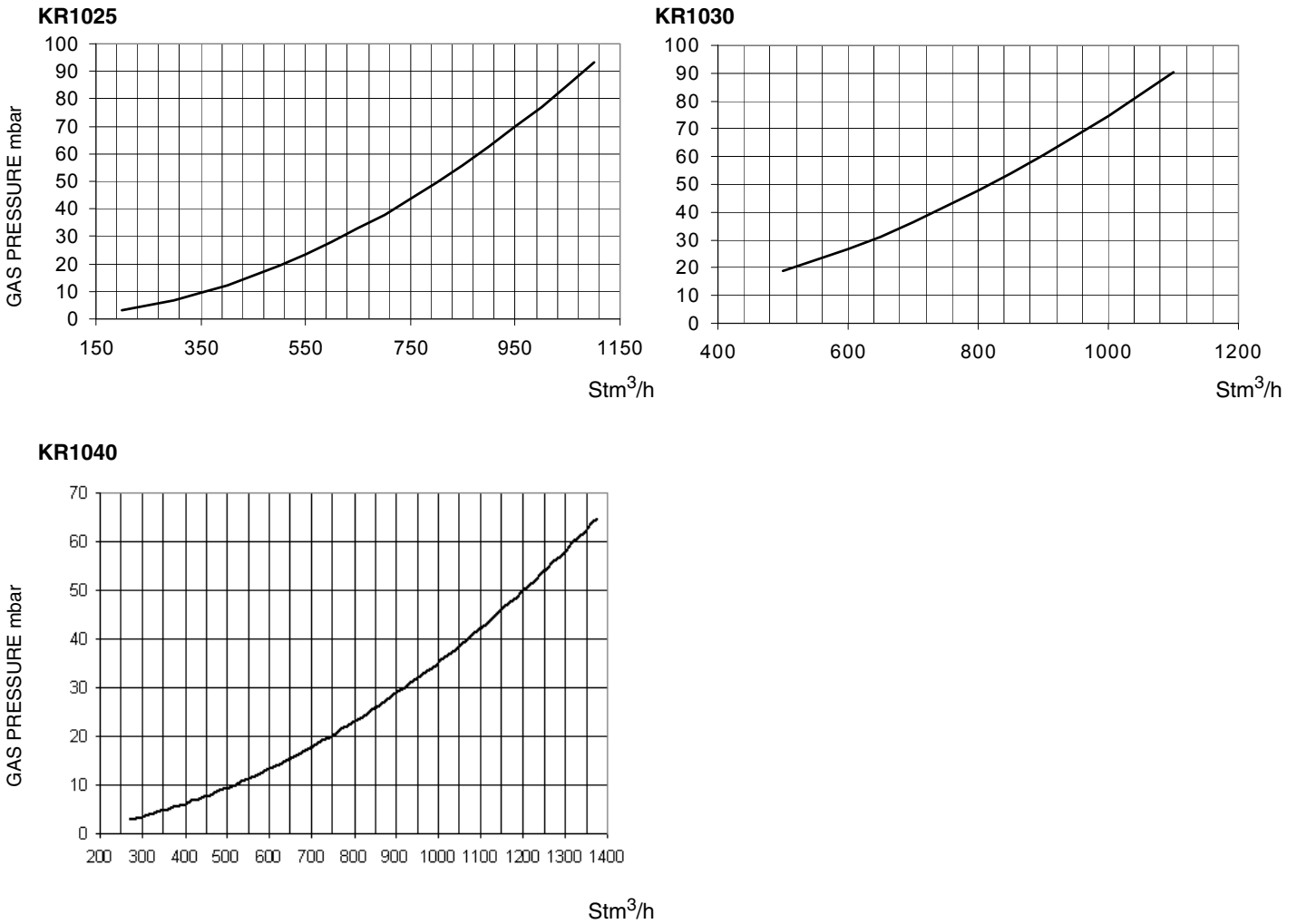

Gas Filter

The gas filters remove the dust particles that are present in the gas, and prevent the elements at risk (e.g.: burners, counters and regulators) from becoming rapidly blocked. The filter is normally installed upstream from all the control and on-off devices.

VPS504 Gas proving system

The VPS504 check the operation of the seal of the gas shut off valves. This check is carried out as soon as the boiler thermostat gives a start signal to the burner, creating, by means of the diaphragm pump inside it, a pressure in the test space of 20 mbar higher than the supply pressure.

When wishing to monitor the test, install a pressure gauge ranged to that of the pressure supply point PA.

If the test cycle is satisfactory, after a few seconds the consent light LC (yellow) comes on. In the opposite case the lockout light LB (red) comes on.

To restart it is necessary to reset the appliance by pressing the illuminated pushbutton LB.

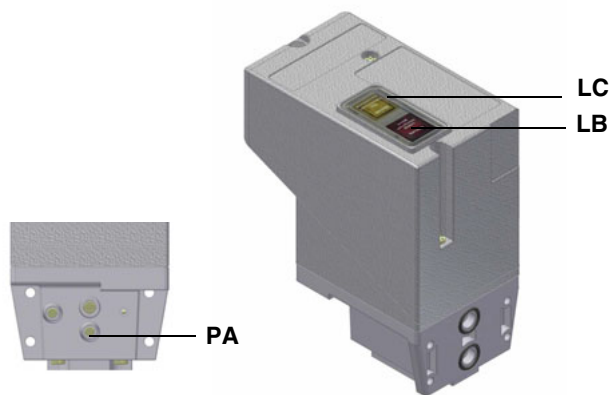

Fig. 19

Adjusting the pilot gas flow rate: gas pressure adjusting pilot valve Brahma EG12*R and pressure governor

To change the pilot gas valve flow rate, proceed as follows:

- 1 remove the protection on the bottom of the valve, moving it counterclockwise (see next picture);
- 2 rotate clockwise the nut 1 as shown in to close the valve or counterclockwise to open.

To perform a finest adjustment, act directly on the pressure governor as follows (see next picture):

- 3 remove the cap **T**: to increase the gas pressure at the outlet use a screwdriver on the screw **TR** as shown below. Screw to increase the pressure, unscrew to decrease; once the regulation is performed, replace cap **T**.

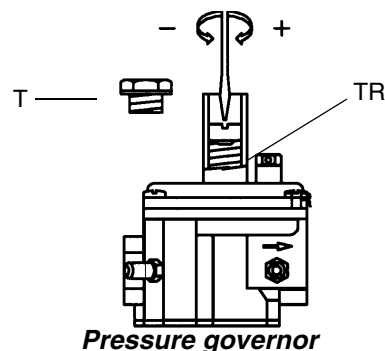
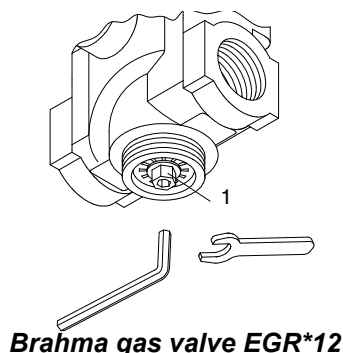

Adjustments - brief description

Adjust the air and gas flow rates at the maximum output (“high flame”) first, by means of the air damper and the adjusting cam respectively.

- Check that the combustion parameters are in the suggested limits.
- Check the flow rate measuring it on the counter or, if it was not possible, verifying the combustion head pressure by means of a differential pressure gauge, as described on par. “Measuring the gas pressure in the combustion head” on page 28.
- Then, adjust the combustion values corresponding to the points between maximum and minimum: set the shape of the adjusting cam foil. The adjusting cam sets the air/gas ratio in those points, regulating the opening-closing of the throttle gas valve.
- Set, now, the low flame output, acting on the low flame microswitch of the actuator in order to avoid the low flame output increasing too much or that the flues temperature gets too low to cause condensation in the chimney.

Adjustment procedure

To change the burner setting during the testing in the plant, follow the next procedure.

On the DUNGS MBC..SE gas valves group, set the pressure regulator to 1/3 of its stroke, using a 2.5 allen key.

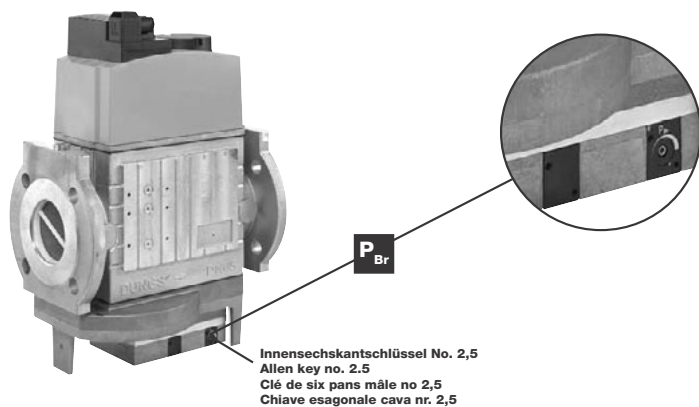

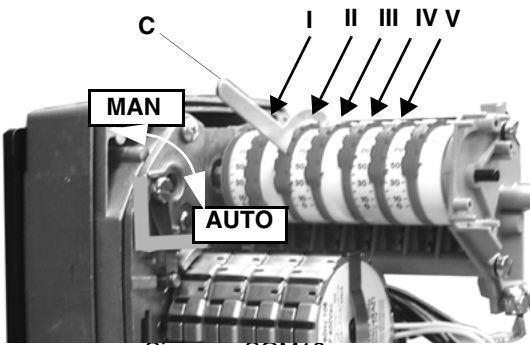

Siemens SQM10

Actuator cams

- I High flame
- II Stand-by and Ignition
- III Low flame (gas)
- IV Low flame (oil)
- V Stroke limitation
- C Tool for cams adjustment

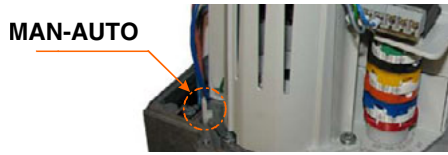

Siemens SQM40

Actuator cams

- I High flame
- II Stand-by and Ignition
- III Low flame (gas)
- IV Low flame (oil)
- VI Stroke limitation

Note: to move the cams, use a screwdriver.

- 1 turn the burner on by selecting GAS fuel by means of the burner **CM** switch (it is placed on the burner control panel - see page 39)
- 2 check the fan motor rotation (see page 25).
- 3 Before starting the burner up, drive the high flame actuator microswitch matching the low flame one (in order to let the burner operates at the lowest output) to safely achieve the high flame stage.
- 4 Start the burner up by means of the thermostat series, closing terminals 3 and 4; wait until the pre-purge time comes to an end and that the burner starts up;
- 5 drive the burner to high flame stage, by means of the thermostat **TAB** (as far as fully-modulating burners, see the related paragraph).
- 6 Then move progressively the microswitch to higher values until it reaches the high flame position; always check the combustion values and eventually adjusting the gas by means of the valves group stabiliser.
- 7 go on adjusting air and gas flow rates: check, continuously, the flue gas analysis, as to avoid combustion with little air; dose the air according to the gas flow rate change following the steps quoted below;
- 8 acting on the pressure stabiliser of the valves group, adjust the **gas flow rate in the high flame stage** as to meet the values requested by the boiler/utilisation:

- **Siemens VGD valves group:** remove cap **T** and act on the **VR** adjusting screw to increase or decrease the pressure and consequently the gas rate; screwing **VR** the rate increases, unscrewing it decreases (see next figure).

- **Dungs MBC..SE valves group:** act on its pressure governor to increase or decrease the pressure and consequently the gas rate.

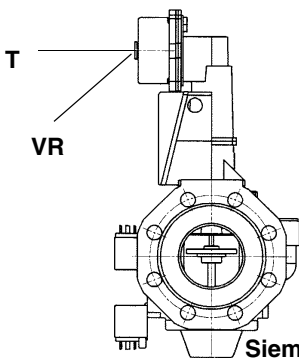

Siemens VGD..

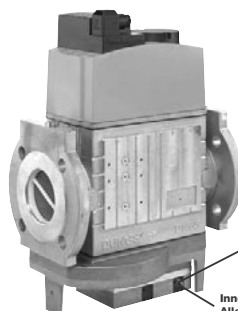

Innensechskantschlüssel No. 2,5
Allen key no. 2,5
Clé de six pans mâle no 2,5
Chiave esagonale cava nr. 2,5

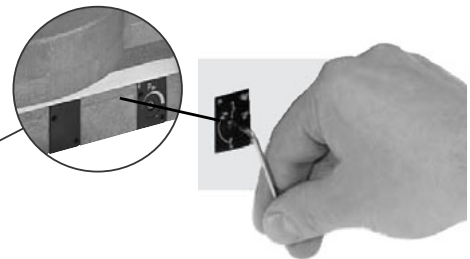

Dungs MBC..SE

- 9 To adjust the **air flow rate in the high flame stage**, loose the **RA** nut and screw **VRA** as to get the desired air flow rate: moving the rod **TR** towards the air damper shaft, the air damper opens and consequently the air flow rate increases, moving it far from the shaft the air damper closes and the air flow rate decreases.

Note: once the procedure is performed, be sure that the blocking nut **RA** is fasten. Do not change the position of the air damper rods.

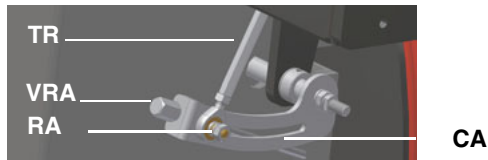

- 10 Only if necessary, change the combustion head position: to let the burner operate at a lower output, loose the **VB** screw and move progressively back the combustion head towards the MIN position, by turning clockwise the **VRT** ring nut. Fasten **VB** screw when the adjustment is accomplished.

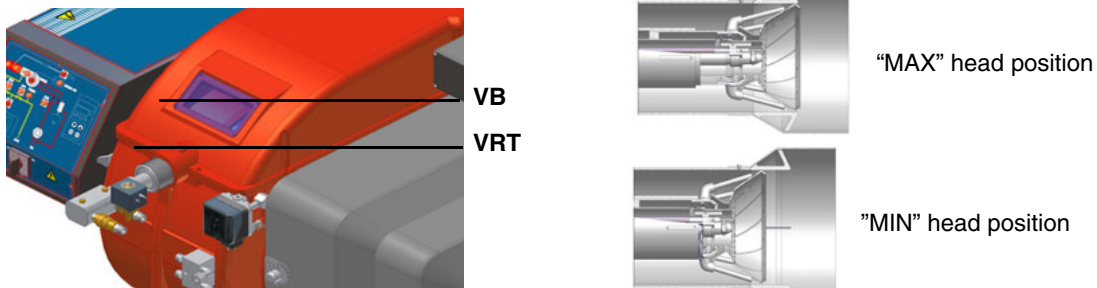

Attention! if it is necessary to change the head position, repeat the air and gas adjustments described above.

- 11 the air and gas rate are now adjusted at the maximum power stage, go on with the point to point adjustment on the **SV1** (gas side) adjusting cam as to reach the minimum output point.

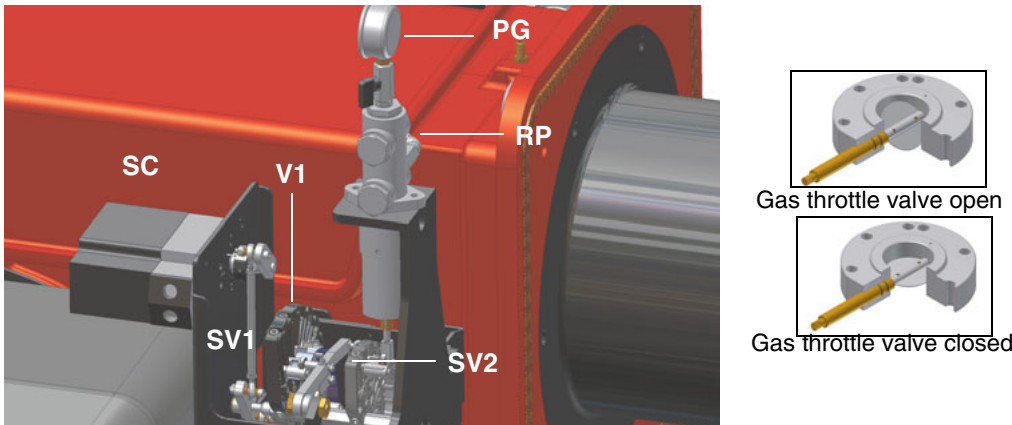

- 12 as for the point-to-point regulation, move the gas low flame microswitch (cam III) a little lower than the maximum position (90°);
 13 set the **TAB** thermostat to the minimum in order that the actuator moves progressively towards the low flame position;
 14 move cam III to the minimum to move the actuator towards the low flame until the two bearings find the adjusting screw that refers to the lower position: screw **V1** to increase the rate, unscrew to decrease.
 15 Move again cam III towards the minimum to meet the next screw on the adjusting cam and repeat the previous step; go on this way as to reach the desired low flame point.
 16 Now adjust the pressure switches (see next paragraph).

Adjusting the air and gas pressure switches

The **air pressure switch** locks the control box if the air pressure is not the one requested. If it happens, unlock the burner by means of the control box unlock pushbutton, placed on the burner control panel.

The **gas pressure switches** check the pressure to avoid the burner operate when the pressure value **VR** is not in the requested pressure range.



Calibration of air pressure switch

To calibrate the air pressure switch, proceed as follows:

- Remove the transparent plastic cap.
- Once air and fuel setting have been accomplished, startup the burner.
- During the pre-purge phase of the operation, turn slowly the adjusting ring nut **VR** in the clockwise direction (to increase the adjusting pressure) until the burner lockout, then read the value on the pressure switch scale and set it to a value reduced by 15%.
- Repeat the ignition cycle of the burner and check it runs properly.

- Refit the transparent plastic cover on the pressure switch.

Calibration of low gas pressure switch

As for the gas pressure switch calibration, proceed as follows:

- Be sure that the filter is clean.
- Remove the transparent plastic cap.
- While the burner is operating at the maximum output, test the gas pressure on the pressure port of the minimum gas pressure switch.
- Slowly close the manual cutoff valve (placed upstream the pressure switch, see gas train installation diagram), until the detected pressure is reduced by 50%. Pay attention that the CO value in the flue gas does not increase: if the CO values are higher than the limits laid down by law, slowly open the cutoff valve as to get values lower than these limits.
- Check that the burner is operating correctly.
- Clockwise turn the pressure switch adjusting ring nut (as to increase the pressure value) until the burner stops.
- Slowly fully open the manual cutoff valve.
- Refit the transparent plastic cover on the pressure switch.

Adjusting the high gas pressure switch (when provided)

To calibrate the high pressure switch, proceed as follows according to its mounting position:

- 1 remove the pressure switch plastic cover;
- 2 if the maximum pressure switch is mounted upstream the gas valves: measure the gas pressure in the network, when flame is off; by means of the adjusting ring nut **VR**, set the value read, increased by the 30%.
- 3 if the maximum pressure switch is mounted downstream the "gas governor-gas valves" group and upstream the butterfly valve: light the burner, adjust it according to the procedure in the previous paragraph. Then, measure the gas pressure at the operating flow rate, downstream the "gas governor-gas valves" group and upstream the butterfly valve; by means of the adjusting ring nut **VR**, set the value read on step 2, increased by the 30%;
- 4 replace the plastic cover.

To calibrate the high pressure switch, proceed as follows:

- 1 remove the plastic cover;
- 2 measure the gas pressure in the network, when flame is off;
- 3 by means of the adjusting ring nut **VR**, set the value read on step 2, increased by the 30%;
- 4 replace the plastic cover.

PGCP Gas leakage pressure switch (with Siemens LDU burner control/Siemens LMV Burner Management System)

- remove the pressure switch plastic cover;
 - adjust the PGCP pressure switch to the same value set for the minimum gas pressure switch;
 - replace the plastic cover.
-
- remove the pressure switch plastic cover;
 - adjust the PGCP pressure switch to the same value set for the minimum gas pressure switch;
 - replace the plastic cover.;

Fully modulating burners

To adjust the fully-modulating burners, use the **CMF** switch on the burner control panel (see next picture), instead of the **TAB** thermostat as described on the previous paragraphs about the progressive burners. Go on adjusting the burner as described before, paying attention to use the CMF switch instead of **TAB**.

The **CMF** position sets the operating stages: to drive the burner to the high-flame stage, set CMF=1; to drive it to the low-flame stage, set CMF=2.

To move the adjusting cam set CMF=1 or 2 and then CMF=0.

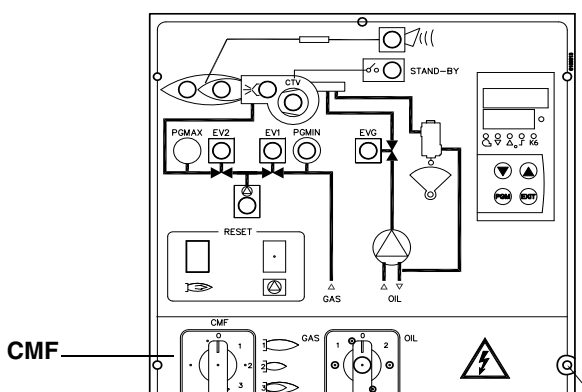

- CMF = 0 stop at the current position
- CMF = 1 high flame operation
- CMF = 2 low flame operation
- CMF = 3 automatic operation

Adjusting heavy oil flow rate

The oil flow rate can be adjusted choosing a by-pass nozzle that suits the boiler/utilisation output and setting the delivery and return pressure values according to the ones quoted on the chart below and the diagram on Fig. 20 (as far as reading the pressure values, see next paragraphs).

DELIVERY PRESSURE bar	RETURN PRESSURE MAX. bar	RETURN PRESSURE MIN. bar
25	20	7-8 (recommended)

Tab. 4

DIMENSIONS	FLOW RATE kg/h	
	Min	Max
40	13	40
50	16	50
60	20	60
70	23	70
80	26	80
90	30	90
100	33	100
115	38	115
130	43	130
145	48	145
160	53	160
180	59	180
200	66	200
225	74	225
250	82	250
275	91	275
300	99	300
330	109	330
360	119	360
400	132	400
450	148	450
500	165	500
550	181	550
600	198	600
650	214	650
700	231	700
750	250	750
800	267	800

Fig. 20

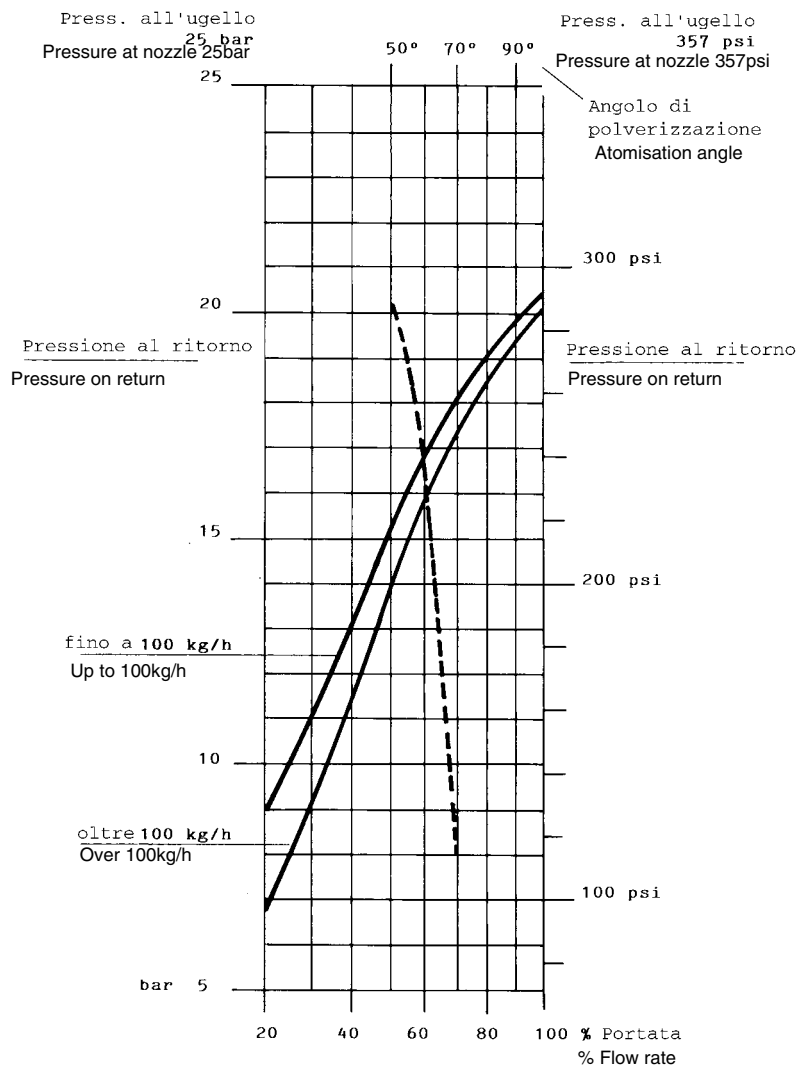

-----Atomisation angle according to the return pressure
 _____ % Flow rate

Example: as for over 100kg/h nozzles, the 80% of the nozzle flow rate can be obtained with a return pressure at about 18bar (see Fig. 20).

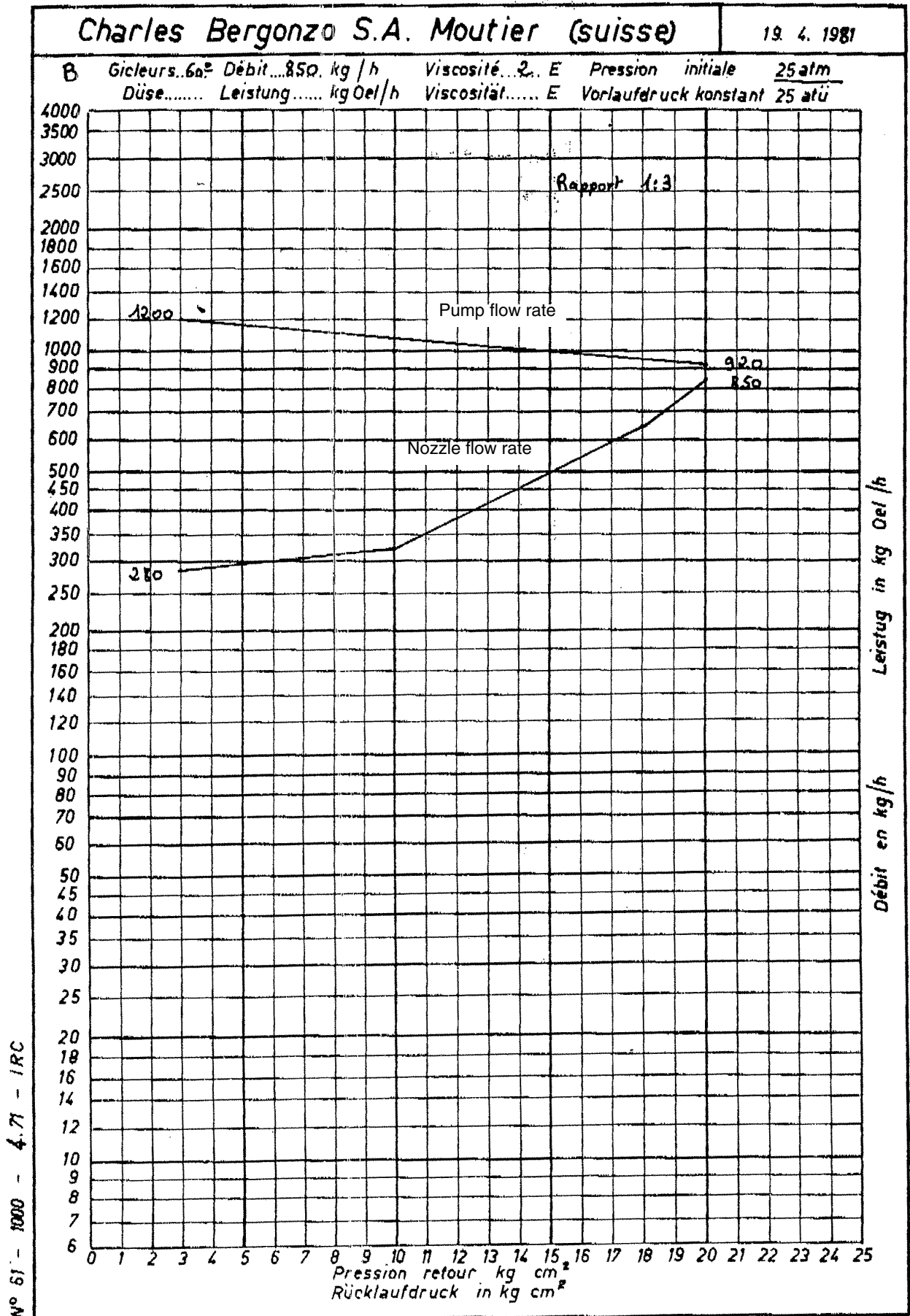

Fig. 21 - Bergonzo nozzle - example with 850kg/h nozzle

- 1 Once the air and gas flow rates are adjusted, turn the burner off, turn the burner on again by means of the **CM** selector to switch to the heavy oil operation (OIL, on the burner control panel - see page 39).
- 2 with the electrical panel open, prime the oil pump acting directly on the related **CP** contactor (see next picture): check the pump motor rotation and keep pressing for some seconds until the oil circuit is charged;

- 3 bleed the air from the **M** pressure gauge port (Fig. 22) by loosening the cap without removing it, then release the contactor.

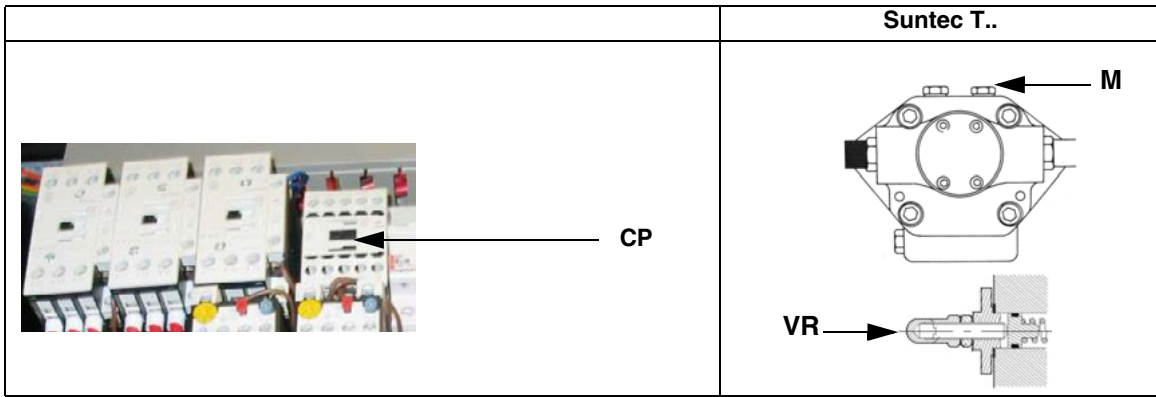
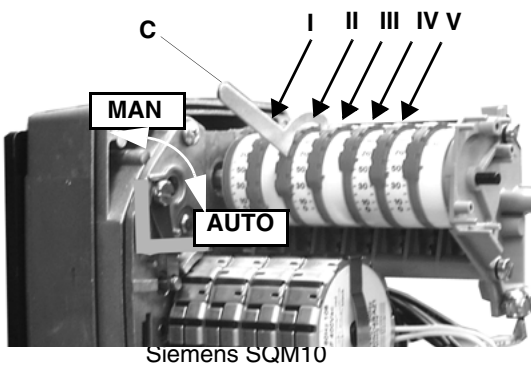

Fig. 22

- 4 Before starting the burner up, drive the high flame actuator microswitch matching the low flame one (in order to let the burner operate at the lowest output) to achieve safely the high flame stage .
- 5 record the high flame value set during the gas operation adjustments (see previous paragraphs);
- 6 Start the burner up by means of the thermostat series, closing terminals 3 and 4; wait until the pre-purge time comes to an end and that the burner starts up;
- 7 drive the burner to high flame stage, by means of the thermostat **TAB** (as far as fully-modulating burners, see the related paragraph).
- 8 Then move progressively the microswitch to higher values until it reaches the high flame position; always check the combustion values and eventually adjusting the oil pressure (see next step).



Siemens SQM10

Actuator cams

- I High flame
- II Stand-by and Ignition
- III Low flame (gas)
- IV Low flame (oil)
- V Stroke limitation
- C Tool for cams adjustment



Siemens SQM40

Actuator cams

- I High flame
- II Stand-by and Ignition
- III Low flame (gas)
- IV Low flame (oil)
- VI Stroke limitation

Note: to move the cams, use a screwdriver.

- 9 the nozzle supply pressure is already factory-set and must not be changed. Only if necessary, adjust the supply pressure as follows (see related paragraph); insert a pressure gauge into the port shown on Fig. 22 and act on on the pump adjusting screw **VR** (see Fig. 22 and page 23) as to get the nozzle pressure at 25bar (according to the nozzle model provided- see page 34).

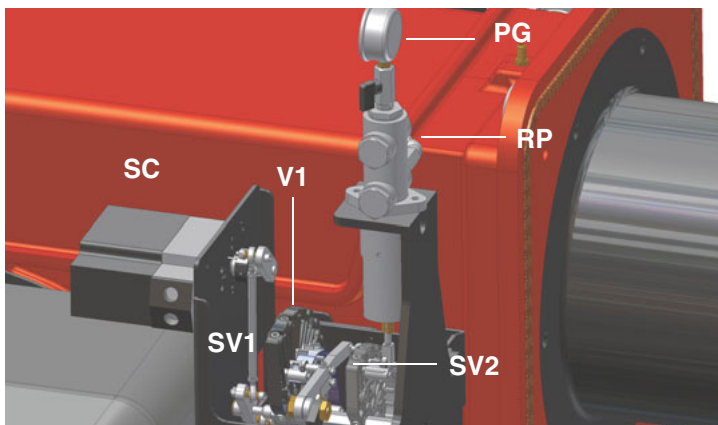

Fig. 23

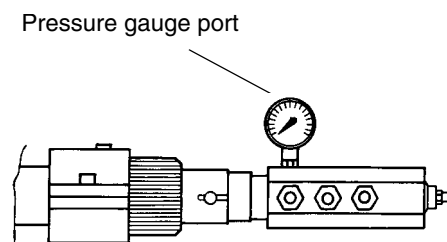

Fig. 24

- 10 in order to get the maximum oil flow rate, adjust the pressure (reading its value on the **PG** pressure gauge) without changing the air flow rate set during the gas operation adjustments (see previous paragraph): checking always the combustion parameters, the adjustment is to be performed by means of the **SV2** adjusting cam screw (see picture above) when the cam has reached the high flame position.
- 11 as for the point-to-point regulation in order to set the cam foil shape, move the oil low flame microswitch (cam IV) a little lower than the maximum position (90°);
- 12 set the **TAB** thermostat to the minimum in order that the actuator moves progressively towards the low flame position;
- 13 move cam IV (oil low flame) towards the minimum to move the actuator towards the low flame until the two bearings find the adjusting screw that refers to a lower position: screw **V2** to increase the rate, unscrew to decrease, in order to get the pressure as shown on chart/diagram on "Adjusting heavy oil flow rate" on page 34, according to the requested rate.
- 14 Move again cam V towards the minimum to meet the next screw on the adjusting cam and repeat the previous step; go on this way as to reach the desired low flame point.
- 15 The low flame position must never match the ignition position that is why cam **IV** must be set 20°- 30° more than the ignition position.
- 16 Set cam V ("stroke limitation cam") 5° higher than the lowest "low flame cam" (cam III or cam IV).
- 17 Turn the burner off; then start it up again. If the adjustment is not correct, repeat the previous steps.
- 18 Replace the actuator and control panel covers.

As far as fully-modulating burners, see paragraph "Fully modulating burners" on page 33.

Oil circuit

The fuel is pushed into the pump 1 to the nozzle 3 at the delivery pressure set by the pressure governor. The solenoid valve 2 stops the fuel immission into the combustion chamber. The fuel flow rate that is not burnt goes back to the tank through the return circuit. The spill-back nozzle is feded at constant pressure, while the return line pressure is adjusted by means of the pressure governor controlled by an actuator coupled to an adjusting cam. The fuel amount to be burnt is adjusted by means of the burner actuator according to the adjustments set (see prevoius paragraph).

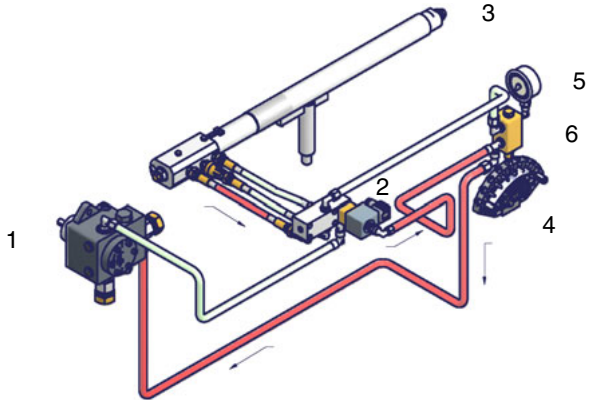

Fig. 25 - Stand-by

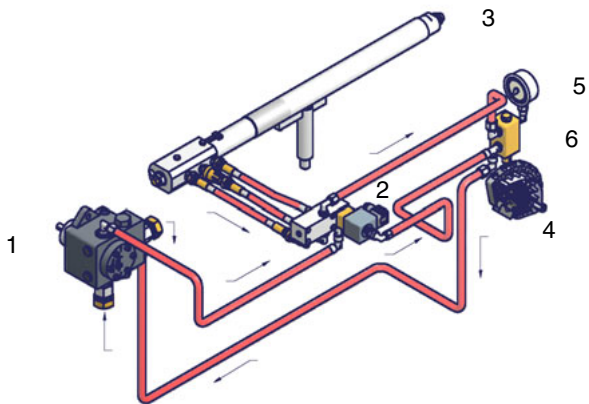

Fig. 26 - Pre-purge

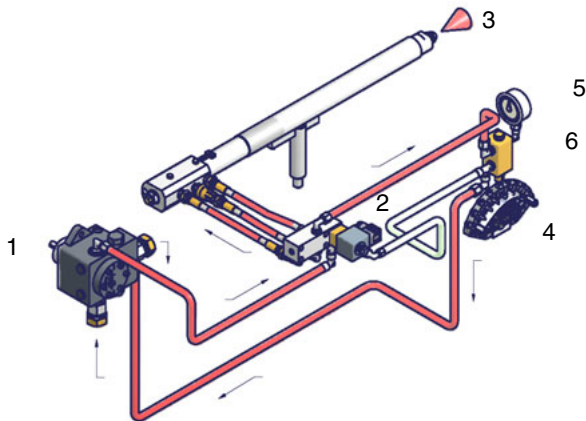

Fig. 27 - Low flame

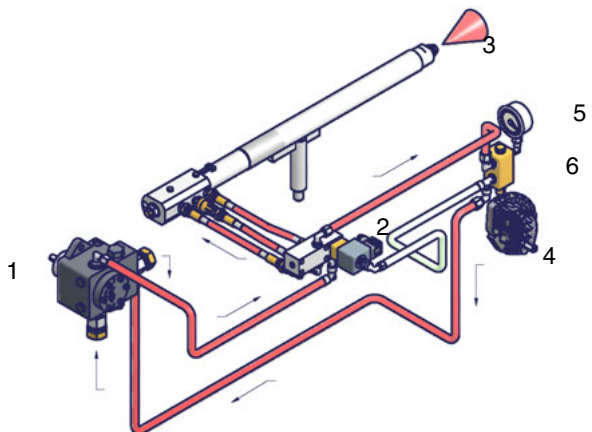

Fig. 28 - High flame

Key

- 1 Oil pump
- 2 Oil solenoid valve
- 3 Nozzle
- 4 Adjusting cam
- 5 Pressure gauge
- 6 Pressure governor

PART II: OPERATION

LIMITATIONS OF USE

THE BURNER IS AN APPLIANCE DESIGNED AND CONSTRUCTED TO OPERATE ONLY AFTER BEING CORRECTLY CONNECTED TO A HEAT GENERATOR (E.G. BOILER, HOT AIR GENERATOR, FURNACE, ETC.), ANY OTHER USE IS TO BE CONSIDERED IMPROPER AND THEREFORE DANGEROUS.

THE USER MUST GUARANTEE THE CORRECT FITTING OF THE APPLIANCE, ENTRUSTING THE INSTALLATION OF IT TO QUALIFIED PERSONNEL AND HAVING THE FIRST COMMISSIONING OF IT CARRIED OUT BY A SERVICE CENTRE AUTHORIZED BY THE COMPANY MANUFACTURING THE BURNER.

A FUNDAMENTAL FACTOR IN THIS RESPECT IS THE ELECTRICAL CONNECTION TO THE GENERATOR'S CONTROL AND SAFETY UNITS (CONTROL THERMOSTAT, SAFETY, ETC.) WHICH GUARANTEES CORRECT AND SAFE FUNCTIONING OF THE BURNER.

THEREFORE, ANY OPERATION OF THE APPLIANCE MUST BE PREVENTED WHICH DEPARTS FROM THE INSTALLATION OPERATIONS OR WHICH HAPPENS AFTER TOTAL OR PARTIAL TAMPERING WITH THESE (E.G. DISCONNECTION, EVEN PARTIAL, OF THE ELECTRICAL LEADS, OPENING THE GENERATOR DOOR, DISMANTLING OF PART OF THE BURNER).

NEVER OPEN OR DISMANTLE ANY COMPONENT OF THE MACHINE.

OPERATE ONLY THE MAIN SWITCH, WHICH THROUGH ITS EASY ACCESSIBILITY AND RAPIDITY OF OPERATION ALSO FUNCTIONS AS AN EMERGENCY SWITCH, AND ON THE RESET BUTTON.

IN CASE OF A BURNER SHUT-DOWN, RESET THE CONTROL BOX BY MEANS OF THE RESET PUSHBUTTON. IF A SECOND SHUT-DOWN TAKES PLACE, CALL THE TECHNICAL SERVICE, WITHOUT TRYING TO RESET FURTHER.

WARNING: DURING NORMAL OPERATION THE PARTS OF THE BURNER NEAREST TO THE GENERATOR (COUPLING FLANGE) CAN BECOME VERY HOT, AVOID TOUCHING THEM SO AS NOT TO GET BURNT.

OPERATION



ATTENTION: before starting the burner up, be sure that the manual cutoff valves are open and check that the pressure upstream the gas train complies the value quoted on paragraph "Technical specifications". Read carefully the "WARNINGS" chapter in this manual.

Select the fuel by turning the switch CM on the burner control panel .

N.B. if the heavy oil is used, be sure the cutoff valves on the delivery and return pipes are OPEN.

- Check that the burner is not locked (LED **C** lights up); if so, reset it by pressing the reset button **D**.
- Check that the series of thermostats (or pressure switches) enable the burner to start up.

Gas Operation

- Check that the gas pressure in the circuit is high enough (LED **E** and **Q** on).
- The valve proving test begins.
- At the beginning of the start-up cycle the the air damper moves to the maximum opening, the fan motor starts and the pre-purge phase begins. During the pre-purge phase the complete opening of the air damper is signalled by the LED **G** on the front panel.
- At the end of the pre-purge stage, the air damper moves to the ignition position, the ignition transformer is energised (signalled by LED **I** on the panel) and, after few seconds the two gas valves EV1 and EV2 are energised (indicator lights **L** and **M** on). Few seconds after the opening of the gas valves, the ignition transformer is de-energised and LED **I** is off.
- To move from the low flame position, the actuator opening time (<10 s) is controlled by the control box. When this time elapses, the burner operates according the plant needs.

Heavy oil Operation

- At the beginning of the start-up cycle the air damper moves to the maximum opening, the fan motor starts and the pre-purge phase begins. During the pre-purge phase the complete opening of the air damper is signalled by LED **G** on the front panel.
- At the end of the pre-purge the air damper is brought to the ignition position and the ignition transformer is energised (signalled by LED **I** on the panel). Few seconds later, the oil valve opens and the ignition transformer is de-energized (LED **I** off).

The burner is now operating and after some seconds the burner is automatically driven into high flame (LED **G** on), or remains in low flame (LED **H** on) according to the plant needs.

As far as fully-modulating burners, refer to the burner modulator manual.

Burner front panel

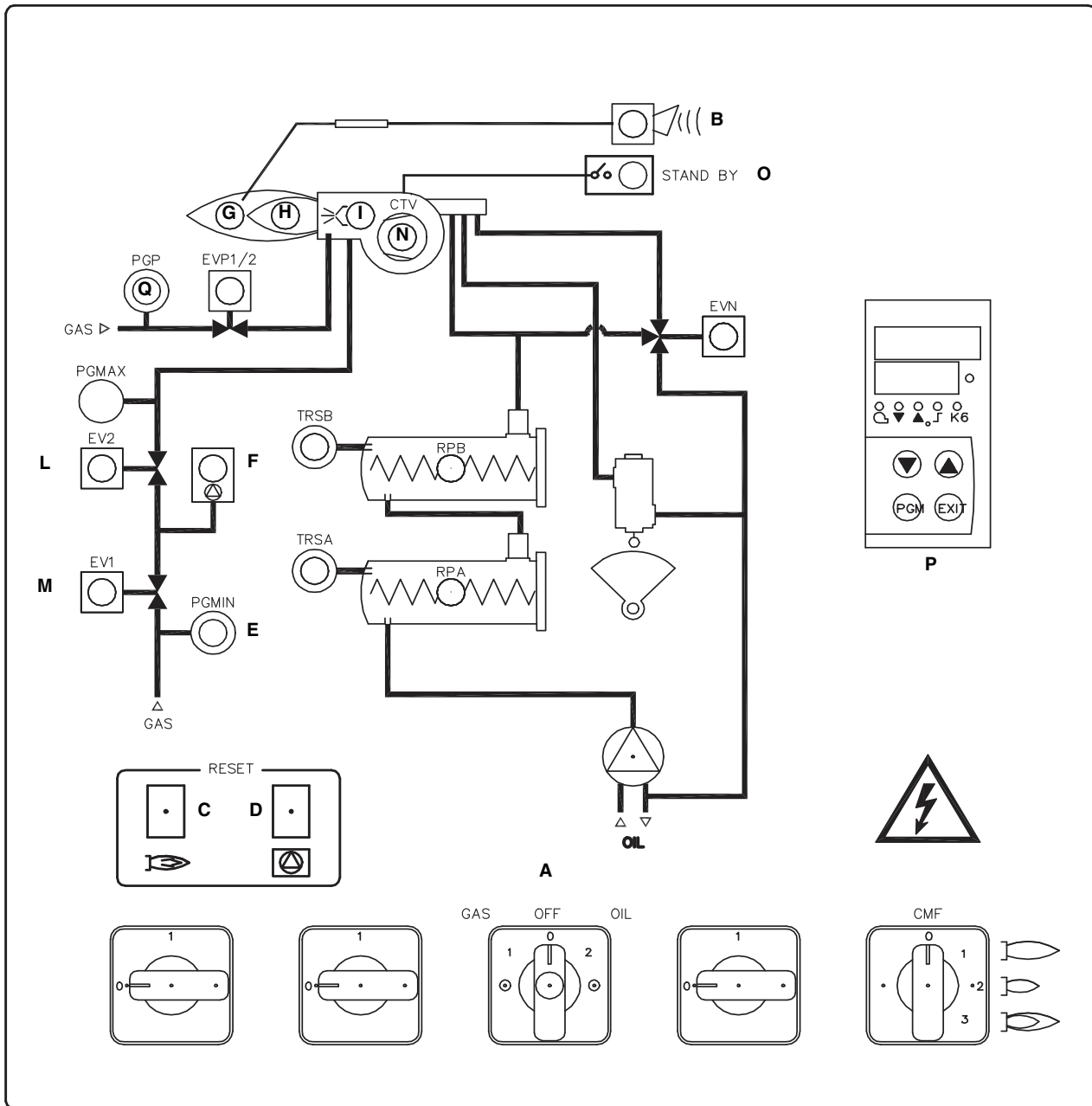

Fig. 29 - Burner control panel

Key

- | | | | |
|---|---|---|--|
| A | ON-OFF mains switch | O | Burner in stand-by signalling lamp |
| B | Lockout signalling lamp | P | Modulator (only fully modulating burners) |
| C | Reset button for burner control device | Q | Pilot pressure switch enabling signalling lamp |
| D | Reset button for burner gas proving system (only for burners fitted with Siemens LDU) | R | Valve EVP operation signalling lamp |
| E | Gas pressure switch enabling signalling lamp | | |
| F | Gas proving system lock signalling lamp | | |
| G | Hig flame operation signalling lamp | | |
| H | Low flame operation signalling lamp | | |
| I | Ignition transformer operation signalling light | | |
| L | Valve EV2 operation signalling light | | |
| M | Valve EV1 operation signalling light | | |
| N | Fan motor thermal cutout intervention signalling lamp | | |

PART III: MAINTENANCE

At least once a year carry out the maintenance operations listed below. In the case of seasonal servicing, it is recommended to carry out the maintenance at the end of each heating season; in the case of continuous operation the maintenance is carried out every 6 months.



WARNING: ALL OPERATIONS ON THE BURNER MUST BE CARRIED OUT WITH THE MAINS DISCONNECTED AND THE FUEL MANUAL CUTOFF VALVES CLOSED!

ATTENTION: READ CAREFULLY THE "WARNINGS" CHAPTER AT THE BEGINNING OF THIS MANUAL.

ROUTINE MAINTENANCE



ATTENTION: when servicing, if it was necessary to disassemble the gas train parts, remember to execute the gas proving test, once the gas train is reassembled, according to the procedure imposed by the law in force.



CAUTION: avoid the contact of steam, solvent and other liquids with the electric terminals of the resistor. On flanged heaters, replace the seal gasket before refitting it.

Periodic inspections must be carried out to determine the frequency of cleaning.

Gas filter maintenance



ATTENTION: Before opening the filter, close the manual cutoff valve downstream the filter and bleed the gas; check that inside the filter there is no pressurised gas.

To clean or remove the filter, proceed as follows:

- 1 remove the cap unscrewing the fixing screws (A);
- 2 remove the filtering cartridge (B), clean it using water and soap, blow it with compressed air (or replace it, if necessary)
- 3 replace the cartridge in its proper position taking care to place it inbetween the guides as not to hamper the cap replacement;
- 4 be sure to replace the Or ring into its place (C) and replace the cover fastening by the proper screws (A).

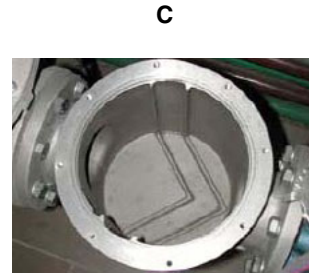
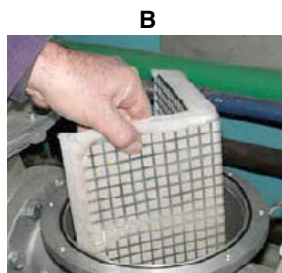

Self-cleaning filter

Fitted only on high viscosity oil burners. Periodically turn the knob to clean the filter.

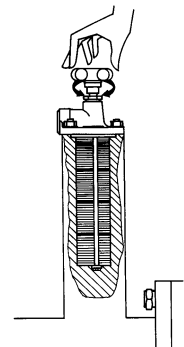

Removing the combustion head

- 1 Remove the cover **H**.
- 2 Slide the photoresistance out of its housing.
- 3 Unscrew the **V** screws that block the gas collector **G**, loosen the three joints **E** and remove the ass.y as shown on the following picture.
- 4 Clean the combustion head by means fo a vacuum cleaner; scrape off the scale by means fo a metallic brush.

Note: to remount the burner, follow the same procedure in the reversed order.

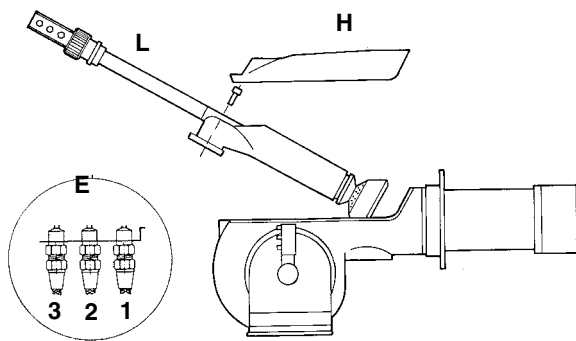

Key

- 1 Inlet
- 2 Return
- 3 Gun opening
- E Oil piping connections
- H Cover
- L Oil gun

Adjusting the ignition electrode

Important Note: check the ignition electrode after each removing of the combustion head.



ATTENTION: avoid the ignition electrode to contact metallic parts (blast tube, head, etc.), otherwise the boiler's operation would be compromised. Check the electrode position after any intervention on the combustion head.

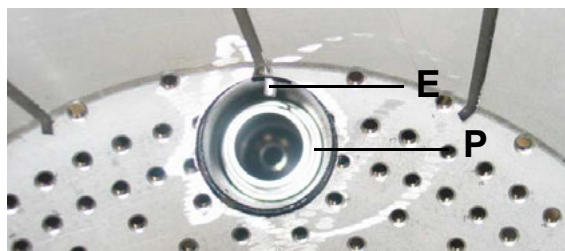

Fig. 30 - Detailed view of the diffuser with pilot (P) and ignition electrode (E)

Observe the values quoted on Fig. 32.

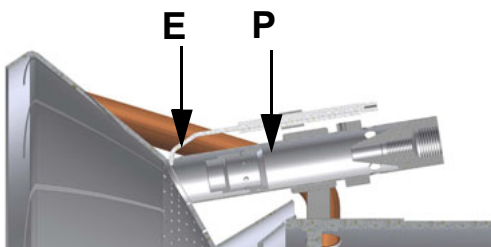

Fig. 31 - Detailed view of the combustion head with pilot (P) and ignition electrode (E)

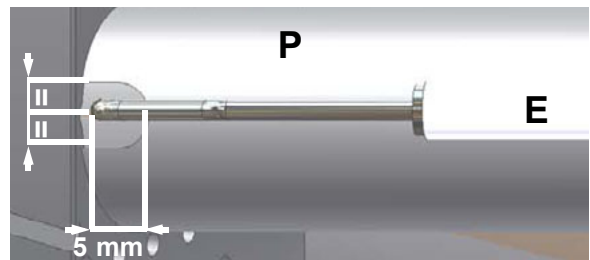

Fig. 32

Replacing the ignition electrode



ATTENTION: avoid the ignition electrode to contact metallic parts (blast tube, head, etc.), otherwise the boiler's operation would be compromised. Check the electrode position after any intervention on the combustion head.

To replace the ignition electrode, proceed as follows:

- 1 remove the burner cover
- 2 disconnect the electrode (E) cable (CE);
- 3 remove the combustion head (see par. "Removing the combustion head");
- 4 loose screw (B) that fasten the ignition electrode (E) to the burner pilot (P);
- 5 remove the electrode and replace it, referring to the values quoted on Fig. 32.

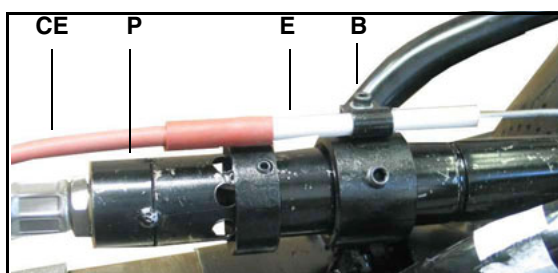
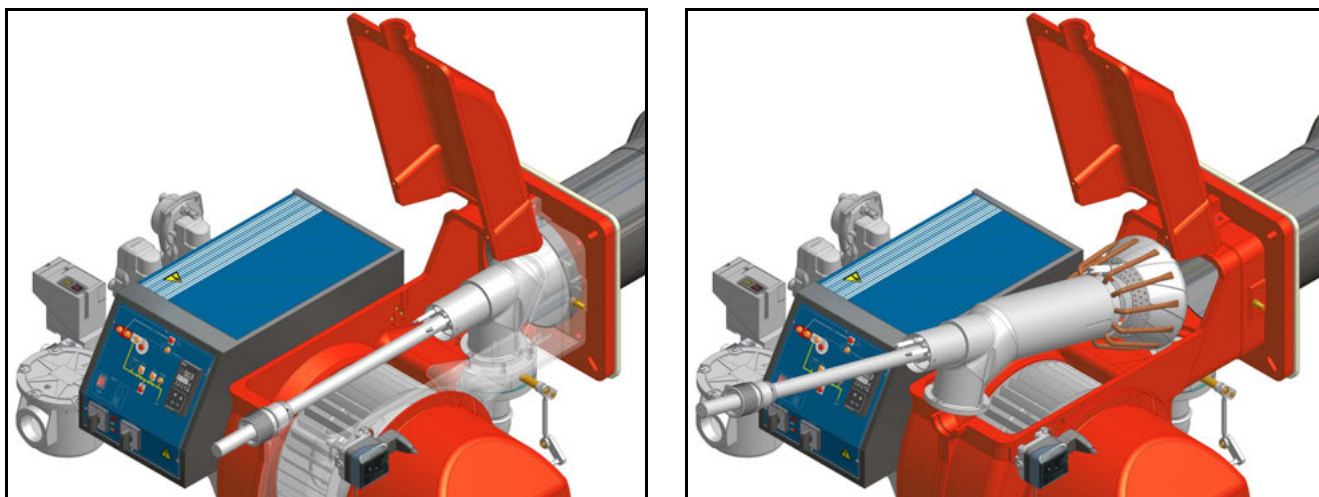

Fig. 33

Removing the oil gun, replacing the nozzle and the electrodes



ATTENTION: avoid the electrodes to get in touch with metallic parts (blast tube, head, etc.), otherwise the boiler operation would be compromised. Check the electrodes position after any intervention on the combustion head.

To remove the oil gun, proceed as follows:

- 1 remove the combustion head as described on the previous paragraph;
- 2 loosen the **VL** screw and remove the oil gun and the electrodes: check the oil gun, replace it if necessary;
- 3 after removing the oil gun, unscrew the nozzle and replace it if necessary;

Caution: adjust the nozzle position according to the air pipe, by means of the **VU** screw, once the **VL** screw is fastened.

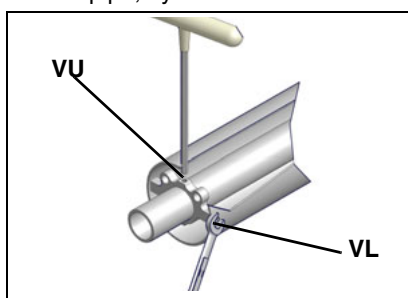

Fig. 34

Cleaning and replacing the detection photocell

To clean/replace the detection photocell, proceed as follows:

- 1 Disconnect the system from the electrical power supply.
- 2 Shut off the fuel supply
- 3 remove the photocell from its slot (see next picture);
- 4 clean the bulbe if dirty, taking care not to touch it with bare hands;
- 5 if necessary, replace the bulb;
- 6 replace the photocell into its slot.



Checking the detection current

To check the detection current follow the diagram on Fig. 35. If the signal is less than the value indicated, check the position of the detection electrode or detector, the electrical contacts and, if necessary, replace the electrode or the detector.

Control box	Minimum detection signal
Siemens LFL1.3..	70 μ A (with UV detector)

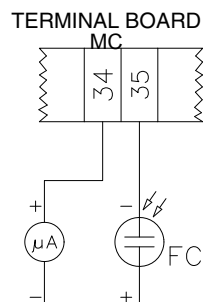

Fig. 35 - Detection with detector QRA...

Seasonal stop

To stop the burner in the seasonal stop, proceed as follows:

- 1 turn the burner main switch to 0 (Off position)
- 2 disconnect the power mains
- 3 close the fuel valve of the supply line

Burner disposal

In case of disposal, follow the instructions according to the laws in force in your country about the "Disposal of materials".

TROUBLESHOOTING

CAUSE / TROUBLE	BURNER DOESN'T START	CONTINUES PRE-PURGE PHASE	DOESN'T START AND GOES TO LOCKOUT	DOESN'T START AND REPEATS CYCLE	STARTS AND REPEATS CYCLE	DOESN'T SWITCH TO HIGH FLAME	LOCKOUT DURING OPERATION	SHUTS OFF AND REPEATS CYCLE DURING OPERATION	NOISY FUEL PUMP
MAIN SWITCH OPEN	●								
LINE FUSES BROKEN	●								
LACK OF GAS	●								
FAULTY GAS PRESSURE SWITCH	●								
FAULTY HIGH PRESSURE SWITCH	●								
FAN THERMAL CUTOUT INTERVENTION	●								
AUXILIARIES FUSE INTERVENTION	●								
FAULTY AIR PRESSURE SWITCH	●		●				●		
FAULTY CONTROL BOX	●	●	●				●		
FAULTY ACTUATOR		●							
AIR PRESSURE SWITCH UNCALIBRATED OR FAULTY							●		
GAS PRESSURE SWITCH UNCALIBRATED			●	●	●			●	
IGNITION TRANSFORMER DEFECTIVE			●						
ELECTRODES BAD POSITION			●						
GAS BUTTERFLY UNCALIBRATED			●						
GAS GOVERNOR DEFECTIVE				●	●			●	
HI-LO FLAME THERMOSTAT DEFECTIVE						●			
ACTUATOR CAM UNCALIBRATED						●			
PHOTOCELL DIRTY OR BAD POSITION							●		
FUEL LOW PRESSURE			●						
FAULT ON LIGHT OIL SOLENOID VALVES			●						
FUEL FILTERS DIRTY									●

BURNER EXPLODED VIEW

ITEM	DESCRIPTION
1	AIR INLET CONE
2	SPACER
3	FLEXIBLE HOSE
4	FLEXIBLE HOSE
5	FLEXIBLE HOSE
6	BUTTERFLY GAS VALVE
7	PHOTOCELL
8.1	LEVERAGE
8.2	ADJUSTING CAM
8.2.1	ADJUSTING CAM FOIL
8.3	ADJUSTING CAM SHAFT
8.4	BUSH
8.5	ACTUATOR
8.6	INDEX LABEL
8.7	ACTUATOR SHAFT
8.8	BRACKET
8.9	BRACKET
8.10	BUSH
8.11	ADJUSTING CAM
8.11.1	ADJUSTING CAM FOIL
8.12.1	PRESSURE GAUGE
8.12.2	PRESSURE GOVERNOR
8.12.3	OIL GOVERNOR CYLINDER
8.12.4	MANUAL VALVE
9	STANDARD BLAST TUBE
10.1	IGNITOR
10.2	COMBUSTION HEAD
10.3	GAS MANIFOLD
10.4.1	ADJUSTING BUSH
10.4.2	STANDARD COMPLETE OIL GUN
10.5	IGNITION CABLE
10.6	GAS FLEXIBLE HOSE
10.7	IGNITION ELECTRODE
11.1	BURNER HOUSING
11.1.1	COVER
11.2	CERAMIC FIBRE PLAIT
11.3	AIR PRESSURE SWITCH

ITEM	DESCRIPTION
11.4	AIR DAMPER
11.5.1	SILENCER
11.5.2	AIR DAMPER SILENCER
11.6	NAME PLATE
11.7	INDEX LABEL
11.8	AIR DAMPER INDEX
12.1	GAS PRESSURE
12.2	GAS SOLENOID VALVE
12.3	GAS GOVERNOR WITH FILTER
13.1	GAS FILTER
13.2.1	"SKP" ACTUATOR
13.2.2	"SKP" ACTUATOR
13.2.3	GAS PROVING SYSTEM
13.2.4	GAS VALVE HOUSING
13.2.5	GAS PRESSURE
13.3	FLANGED REVERSIBLE CURVE
13.4	REVERSIBLE PIPE
13.5	FLANGED PIPE
14.1	OIL MANIFOLD
14.2	SOLENOID VALVE
15.1	MOTOR
15.2	FAN WHEEL
16.1	BOARD
16.2	COVER
16.3.1	FRONT CONTROL PANEL
16.3.2	LIGHT
16.3.3	LIGHT
16.3.4	LOCK-OUT RESET BUTTON
16.3.5	PROTECTION
16.3.6	SWITCH
16.3.7	SWITCH
16.4.1	CONTROL BOX
16.4.2	IGNITION TRANSFORMER
16.4.3	CONTROL BOX SOCKET
16.5	OUTPUT CONTROLLER
17	RING NUT
18.1	OIL MANIFOLD

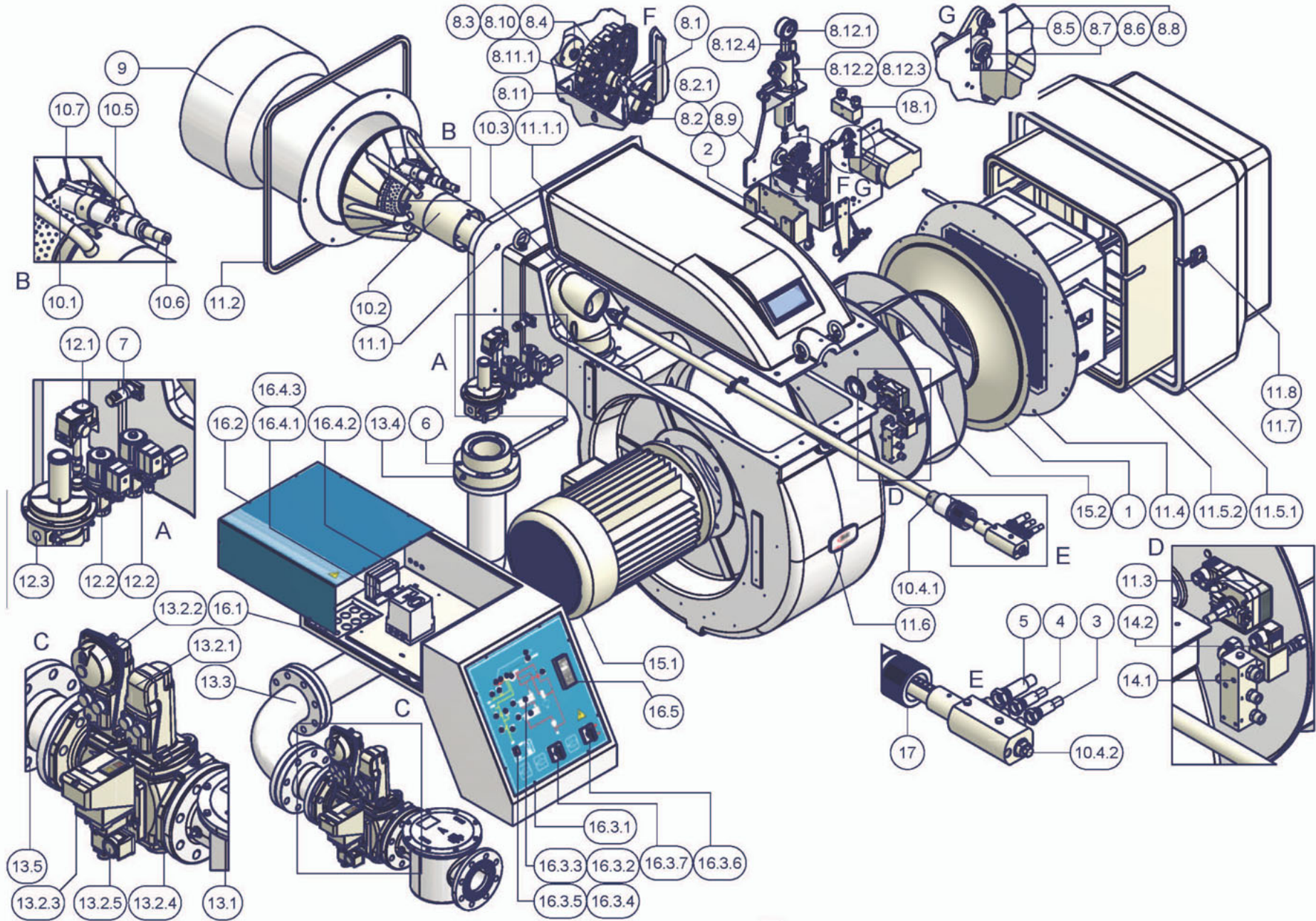

SPARE PARTS

Description	Code		
	KR1025	KR1030	KR1040
VALVE PROVING SYSTEM (SIEMENS LDU)	-	-	2020413
CONTROL BOX (SIEMENS LFL)	2020448	2020448	2020448
IGNITION ELECTRODE	2080258	2080258	2080258
OIL FILTER	2090238	2090238	2090238
GAS FILTER - DN65	2090117	2090117	2090117
GAS FILTER - DN80	2090112	2090112	2090112
GAS FILTER - DN100	2090113	2090113	2090113
CERAMIC FIBRE PLAIT	2110312	2110312	2110312
FAN WHEEL	2150063	2150058	2150058
AIR PRESSURE SWITCH	2160097	2160097	2160097
LOW GAS PRESSURE SWITCH- DUNGS GW150 A5	2160077	-	-
LOW GAS PRESSURE SWITCH- DUNGS GW150 A6	2160086	2160086	2160086
LOW GAS PRESSURE SWITCH- DUNGS GW500 A6	2160087	2160087	2160087
LOW GAS PRESSURE SWITCH- DUNGS GW500 A5	2160089	2160089	2160089
IGNITION TRANSFORMER	2170301	2170301	2170301
PUMP MOTOR	2180283	2180257	2180257
FAN MOTOR	21802A2	2180294	2180292
GAS VALVE GROUP - DN65 - Siemens VGD40..	2190172	2190172	2190172
GAS VALVE GROUP - DN80 - Siemens VGD40..	2190169	2190169	2190169
GAS VALVE GROUP - DN100 - Siemens VGD40..	2190174	2190174	2190174
GAS VALVE GROUP - DN125 - Siemens VGD40..	-	-	2190184
GAS VALVE ACTUATOR SKP15	2190181	2190181	2190181
GAS VALVE ACTUATOR SKP25	2190183	2190183	2190183
GAS VALVE GROUP - DN65 - Dungs MBC1900SE	21903M6	21903M6	21903M6
GAS VALVE GROUP - DN80 - Dungs MBC3100SE	21903M7	21903M7	21903M7
GAS VALVE GROUP - DN100 - Dungs MBC5000SE	21903M8	21903M8	21903M8
PILOT SOLENOID VALVE	2190502	2190502	2190502
OIL SOLENOID VALVE	2190437	2190437	2190437
GAS PROVING SYSTEM	2191604	2191604	2191604
FLEXIBLE HOSE L=600 1/2"	2340059	2340059	2340059
FLEXIBLE HOSE L=385 3/8"	2340088	2340088	2340088
FLEXIBLE HOSE L=435 3/8"	2340089	2340089	2340089
FLEXIBLE HOSE L=800 1/2"	234FX07	234FX07	234FX07
FLEXIBLE HOSE L=347 1/2"	234FX24	234FX24	234FX24
SMALL ADJUSTING CAM FOIL	2440013	2440013	2440013
BIG ADJUSTING CAM FOIL	2440014	2440014	2440014
ACTUATOR SIEMENS SQM10	2480004	2480004	2480004
UV PROBE	2510001	2510001	2510001
MOTOR-PUMP COUPLING	2540133	2540133	2540133
ADJUSTMENT THERMOMETER (50°-200°)	2560026	2560026	2560026
SAFETY THERMOMETER	2560028	2560028	2560028
OIL GOVERNOR	25700A7	2570008	25700E6
OIL GOVERNOR SUNTEC TV	2570036	2570036	2570036
BURNER MODULATOR (only on fully-modulating burners)	2570112	2570112	2570112
PUMP: SUNTEC T	2590124	2590148	2590148
NOZZLE - FLUIDICS	2610203	2610203	2610203
NOZZLE - BERGONZO B	-	2610210	2610210
NOZZLE - BERGONZO C	-	-	2610213
PRESSURE GOVERNOR WITH FILTER	2800085	2800085	2800085
COMBUSTION HEAD	3060270	3060277	3060292
BLAST TUBE	30910H1	30910H2	30910Q8
IGNITION CABLE	6050143	6050143	6050143
OIL HEATER RESISTOR 24 kW	6060008 x 2	6060008 x 2	6060008 x 2
CARTRIDGE AUXILIARY RESISTOR	60600010	60600010	60600010

WIRING DIAGRAMS

WIRING DIAGRAM - Progressive burners

WIRING DIAGRAM SE12-082 - Fully-modulating burners

See the attached wiring diagrams.

ATTENTION:

- 1 - Electrical supply 400V 50Hz 3N a.c.
- 2 - Don't reverse phase with neutral
- 3 - Ensure to the burner a proper hearthing

APPENDIX

SIEMENS LFL 1.3.. CONTROL BOX

Automatic programme in the event of interruption and indication of position when interrupted

By default, in the event of any kind of interruption, the flow of fuel is immediately interrupted. At the same time the programmer stops and this indicates the position at the time of the interruption.

A symbol on the indicator disc shows each time the type of stoppage:

- ◀ No start-up (for example fault in the CLOSED signal for the limit contact "Z" at terminal 8 or some other contact between the terminals 12 and 4 or 4 and 5 is not closed).
- ◀ Start-up suspended because of a fault in the OPEN signal for the limit contact "A" at terminal 8.
- P Block due to absence of air pressure signal. From this moment onwards any absence of air pressure will cause a block.
- Block due to malfunction of the flame detector circuit.
- ▼ Start-up interrupted because there is a fault in the MINIMUM signal for the auxiliary contact of the damper servo motor at terminal 8.
- 1 Block due to absence of flame signal at the end of the 1st safety period.

From this moment onwards any absence of a flame signal will cause a block.

- 2 Block due to absence of flame signal at the end of the 2nd safety period (flame signal of main burner).
- Block due to absence of flame signal or air pressure during operation.

Where a block stoppage occurs at any moment between switch on and pre-ignition without registering any symbol, the cause is normally an unscheduled flame signal.

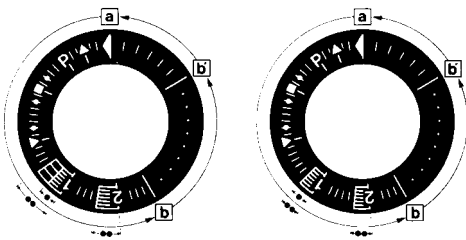

a-b Start-up programme

b-b' For time variants: move the programmer on to the automatic stop after the burner starts up (b' = position of the programmer during normal burner operation).

b(b')-a Post-ventilation programme after a regulation stop. At the start-up position "a" the programmer stops automatically.

. Safety time duration for mono-tube burners

.. Safety time duration for twin-tube burners

The apparatus can be reset immediately after a block. After resetting (and after the elimination of any problem causing the stoppage or after a power failure) the programmer returns to its start-up position. In this event only the terminals 7, 9, 10 and 11 are live in accordance with the monitoring programme. Only after this the device programs a new startup.

Operation

The wiring system and also the control system of the programmer "P" have already been given in this manual. The response signals required for the active parts and the flame monitor circuit are shown by a hatching. In the absence of these response signals the mechanism interrupts the start-up programme; the exact time of the interruption can be identified from the visual indicator and will cause a block if the safety code requires it.

- A consent to start-up by means of the thermostat or pressostat "R"
- A-B start-up program
- B-C normal burner operation
- C regulation stop caused by "R"
- C-D programmer returns to start-up position A.

During the regulation stop only terminals 11 and 12 are live and the damper, through the limit contact "Z" of its servo-motor is in the CLOSED position. The flame detector circuit F is activated (terminals 22 and 23 or 23/4) for the detector test and the paracitic light test.

Where the burners do not have dampers (or have an independent 00 damper control mechanism) there must be a bridge between terminals 6 and 8, otherwise the mechanism will not start up the burner.

For a burner to start up the following conditions must be met:

- Mechanism not blocked/reset.
- Damper closed. Limit contact switch Z must be in the CLOSED position and allow current to flow between terminals 11 and 8.
- Any contacts checking that the fuel valve (bv...) is closed, or other contacts with similar functions, must be closed between terminal 12 and the air pressostat LP.
- The contact for the air pressostat LP must be in the off position (LP test) so as to feed terminal 4.
- The gas pressostat contacts GP and the safety thermostat and pressostat contacts W must also be closed.

Start-up program

A Start-up

(R closes the start-up control ring between terminals 4 and 5)

The programmer starts up. At the same time the ventilator motor is fed through terminal 6 (only for pre-ventilation) and, after t7, the ventilator motor or the combustion gas exhaust fan is fed through terminal 7 (pre-ventilation and post-ventilation).

At the end of t16, the command opening the damper passes through terminal 9; during the damper opening time the programmer does not move since terminal 8, through which the programmer is fed, is dead.

Only once the damper is fully open and the limit contact switch A has switched on, feeding terminal 8, does the programme proceed.

t1 Pre-ventilation time with damper fully open (nominal air flow).

Shortly after the beginning of the pre-ventilation time, the air pressostat should switch off the current between terminals 4 and 13; otherwise the apparatus would block (air pressure monitor).

At the same time the terminal 14 should be live since current feeding the ignition transformer and the fuel valves passes through this circuit.

During pre-ventilation time the flame detector circuit is checked and in the event of an operational defect the monitor brings about a block.

At the end of the pre-ventilation time the monitor automatically moves the damper servo-motor, through terminal 10, to the flame ignition position which is governed by the auxiliary contact "M".

During this period the programmer stops until terminal 8, is again activated through contact "M".

After a few seconds the little programmer motor is directly fed by the active part of the apparatus.

After this point terminal 8 plays no further part in the burner ignition process.

Mono-tube burner

t3 Pre-ignition time waiting the response from the fuel valve at terminal 18.

t2 Safety time (start up flame strenght); at the end of the safety time a flame signal should appear at terminal 22 of the amplifier and it should stay on until a regulation stop; if this does not happen the mechanism will block.

t4 Interval; at the end of t4, terminal 19 is live.

t5 Interval At the end of t5 terminal 20 is live. At the same time the monitor outlets from 9 and 11 and terminal 8 into the active part of the apparatus are kept galvanically separated so as to protect the monitor itself from recovery voltage through the capacity regulator circuit.

Twin-tube burners (**)

t3 Preignition time until the all clear to the pilot burner valve at terminal 17.

t2 First safety time (pilot flame strenght); at the end of the safety time a flame signal should appear at terminal 22 of the amplifier and it should stay on, until a regulation stop; if it does not, the apparatus will block.

t4 Interval until the consent to the fuel valve at terminal 19, for the first flame of the main burner.

t9 2nd safety time; at the end of the second safety time the main burner should be lit by means of the pilot. At the end of this period, terminal 17 is dead and therefore the pilot burner will be out.

t5 Interval; at the end of t5 terminal 20 is live. At the same time the monitor outlets from 9 to 11 and the terminal 8 at the input of the active part of the apparatus are galvanically separated so as to protect the apparatus itself from recovery voltage through the strenght regulator circuit.

When the strenght regulator LR at terminal 20 gives the consent, the start-up programme for the apparatus comes to an end. Depending on time variants, the programmer stops either immediately or at the end of a set time, without effecting the position of the contacts.

B Operational position of the burner

B-C Burner operation (production of heat)

While the burner is working the strenght regulator controls the damper, according to the demand for heat, by means of the positioning at nominal load of the auxiliary contact "V" of the damper servocontrol.

C Regulation stop for operation of "R"

When there is a regulation stop the fuel valves immediately close. At the same time the programmer starts to programme:

t6 Post-ventilation time (post-ventilation with the ventilator "G" at terminal 7). Shortly after beginning of the post-ventilation time terminal 10 becomes live and moves the damper to the "MIN" position. The full closure of the damper only happens towards the end of the post-ventilation time and is prompted by an automatic signal from terminal 11

t13 Admissible post-ignition time

During this time the flame monitor circuit may still receive a flame signal without the apparatus blocking.

D-A End of automatic programme

At the end of t6, at the point where the programmer and the automatic contacts have reverted to the starter position, the detection probe test restarts.

During an operational stop even an unscheduled flame signal lasting a few seconds can cause a block because during this period an NTC in the circuit acts as retarder. This means that brief unscheduled influences cannot cause a block.

(**) Times t3, t2 and t4 only apply only to safety devices in the series O1.

Specifications

Mains voltage	220V -15%...240V +10%
Frequency	50Hz -6%...60Hz +6%
Absorbed capacity	3.5 VA
Built-in fuse	T6.3/250E slow action DIN41571 No. 451915070
External fuse	max. 16A
Interference	N-VDE0875
Flow permitted at terminal 1	5A (DIN 0660 AC3)
Flow permitted at control terminals	4A (DIN 0660 AC3)

Flow at monitor contacts:

input at terminals 4 & 5	1A, 250V
input at terminals 4 & 11	1A, 250V
input at terminals 4 & 14	function of the load at terminals 16 and 19, min. 1A, 250V

Emplacement

Protection

Permitted ambient temp

Min. temperature (trans/storage) -50° C

Weight:

apparatus approx. 1,000g.

base approx. 165g.

Ionisation monitor

voltage in detector electrode	
normal working	330V ±10%
test	380V ±10%
short circuit current	max. 0,5 mA
Ionisation current, min.request	6 µA
max. permitted length for connecting cables	
normal cable (laid separately**)	80m
armoured cable (high frequency) protection at terminal 22	140m

UV monitor

Voltage in UV detector	
normal working	330V ±10%
test	380V ±10%
Detector current, min. request*	70µA
Max. detector current	
normal working	630 µA
test	1300 µA
Max.length of connecting cable	
normal cable (laid separately**) 100m	
armoured cable (high frequency) protected at terminal 22	200m

Weight

QRA2 60 g

QRA10 450 g.

*Connect up in parallel to the measuring device a condenser 100µF, 10...25V.

** The wire connecting up the detector electrode should not be in the same sleeve as the other conductor wires.

Ignition spark monitor with QRE1 series 02 detector

Minimum detector current 30µA

Operating times

t7 initial delay for ventilator G2	2
t16 initial delay of air damper OPEN consent	4
t11 opening time for damper	any
t10 initial delay for air pressure monitor	8
t1 pre-ventilation time with damper open	36
t12 travel time for air damper to MIN position	any
t3 t3' pre-ignition time	t3 t3'
t2 t2' safety time (1st safety time for burners with intermittent pilot lighter)	t2 t2'
t4 t4' interval between start of t2 and response to valve at terminal 19	t4 t4'

t9 2nd safety time for burners with intermittent pilot lighter 2

t5 interval between end of t4 and response at terminal 20 10

t20 interval before programmer cuts out after start-up-duration of start-up 60

t6 post-ventilation time (G2 only) 12

t13 permitted post-ignition time 12

t16 initial delay from opening consent of the air damper

t20 interval until the automatic shut-off of the programming mechanism after the burner start

Key

A	limit contact switch for damper OPEN position
AI	block remote signal
AR	main relay (working network) with contacts "ar"
AS	Monitor fuse
BR	block relay with "br" contacts
BV	fuel valve
EK	reset button
FE	detector electrode of ionisation circuit
FR	flame relay with "fr" contacts
G	ventilator motor or burner motor
GP	gas pressure switch
H	main interruptor switch
L	block stoppage LED
LK	air damper
LP	air pressostat
LR	safety regulator
M	auxiliary contact switch for damper "MIN" position
QRA	UV detector
QRE	ignition spark detector
R	thermostat or pressostat
S	fuse
SA	damper servo-motor
SM	synchronous programmer motor
V	flame signal amplifier
V	in case of servo-motor: auxiliary contact for response to fuel valve with regard of damper position
W	safety pressostat or thermostat
Z	ignition transformer
Z	in case of servomotor: end of limit contact switch for damper CLOSED position
ZBV	pilot burner fuel valve
°	for mono-tube burners
°°	for twin-tube burners

- (1) input for raising QRA detector voltage to test level
- (2) input for excitation of flame relay during flame detector test circuit (contact XIV) and during safety time (contact IV)
- (3) Do not press EK for more than 10 seconds

Programmer diagram

t1	pre-ventilation time
t2	safety time
*t2	'1st safety time
t3	pre-ignition time
*t3	'pre-ignition time
t4	interval for creating current between terminals 18 and 19
*t4	'interval for creating current between terminals 17 and 19
t5	interval for creating current between terminals 19 and 20
t6	post-ventilation time
t7	interval between startup consent and current created at terminal 7
t8	duration of start-up
*t9	2nd safety time
t10	interval before air pressure monitoring begins
t11	damper opening travel time
t12	damper closure travel time
t13	permissible post-combustion time
t16	initial delay of damper OPEN response
t20	interval before programmer automatically stops

* These times are valid with the use of a series 01 safety device for monitoring burners with intermittent pilot lighter.

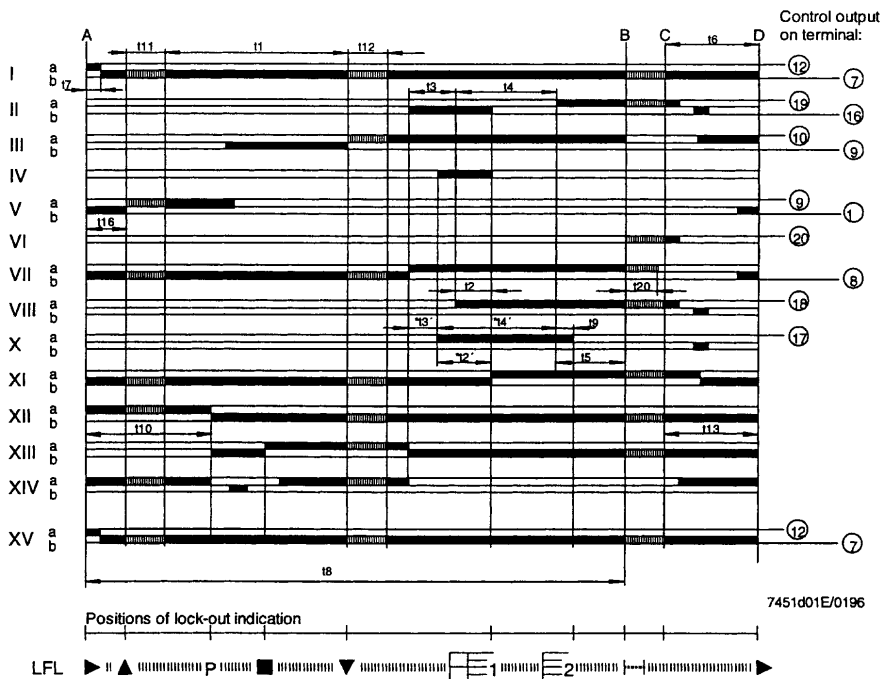
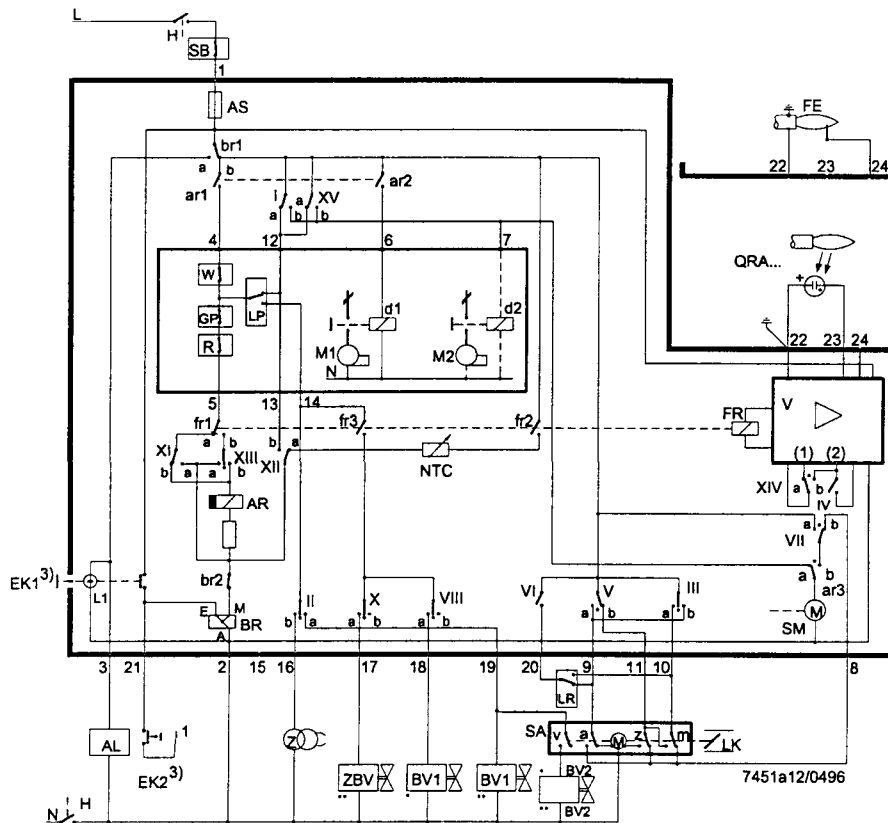

VALVE PROVING SYSTEM SIEMENS LDU11

The LDU11... gas valve proving system is designed for use in gas-fired plant equipped with two safety shut-off valves. During each startup cycle, the control unit automatically programs the valve proving test and, in the event of a leak, prevents burner startup.

The LDU11... control unit is designed to provide automatic gas valve proving (leakage test) based on the pressure proving principle. It is for use in gas-fired plant with or without vent pipe to the atmosphere. For plants without vent pipe, where DIN/DVGW regulations apply, refer to the hints given on "Connection examples with vent pipe to the atmosphere".

Gas valve proving is initiated automatically with every burner startup using one or two standard pressure monitors, either

- prior to burner startup,
- during the pre-purge time, if it lasts at least 60 s,
- immediately after the controlled shutdown, or
- on completion of the burner control's control program, e.g. on completion of the post-purge time

The valve proving test is based on the two-stage pressure proving principle: first, the valve on the mains side is tested by evacuating the test space and by monitoring the atmospheric pressure in it. Then, the valve on the burner side is checked by pressurizing the test space and by monitoring the gas pressure. If the pressure increases excessively during the

first test phase (Test 1), or decreases excessively during the second test phase (Test 2), the control unit inhibits burner startup and goes to lockout. In that case, the lockout reset button lights up to indicate the fault. Remote indication of the fault is also possible.

A program indicator, which stops whenever a fault occurs, indicates which of the two valves is leaking.

Mode of operation

To carry out the first phase of the valve proving test, called "Test 1", there must be atmospheric pressure in the length of pipe between the two valves to be tested. In plants with a vent to the atmosphere, this pressure is available if the valve proving test is conducted prior to or during the pre-purge time. In plants without a vent pipe, atmospheric pressure is made available as the control unit opens the valve on the burner side during the time "t4". If the valve proving test is performed after the operation of the burner, the valve on the burner side after the controlled shutdown can be kept open until "t4" has elapsed, thus reducing the pressure in the test space and making certain its gas content is burnt off in the combustion chamber during the post-purge time. A prerequisite for this procedure is an appropriate control program of the burner control as provided by Landis & Staefa burner controls type LFE..., LFL..., LGK.... or LEC.... The test space is closed off after it has been evacuated.

During the first test phase (Test 1) which follows immediately, the control unit checks if the atmospheric pressure in the test space is maintained using the pressure monitor. If the valve on the mains side is leaking, causing the pressure to rise above the switching point of the pressure monitor, the control unit initiates an alarm and goes to lockout.

The program indicator then stops and indicates "Test 1".

If the pressure does not increase because the valve closes correctly, the control unit immediately programs the second test phase (Test 2). To do this, the valve on the mains side is pressurized ("filling" of test space). During the second test phase, the pressure may not fall below the switching point of the pressure monitor due to a leak of the valve on the burner side.

If it does, the control unit goes to lockout again, thus inhibiting burner startup.

On the successful completion of the second test phase, the control unit closes the internal control loop between terminals 3 and 6 (circuit path: terminal 3 - contact "ar 2" - terminals 4 and 5 - contact III - terminal 6). This control loop is usually included in the start control loop of the burner control.

After the control loop has been closed, the programming mechanism of the control unit returns to its start position where it switches itself off. During these "idle steps", the position of the control contacts of the programming mechanism remains unchanged.

Program and lockout indicator

When the unit goes to lockout, the programming mechanism stops and also the position indicator fitted to the spindle of the mechanism. The symbol that stops above the reading mark not only indicates during which test phase lockout occurred, but also after how many programming steps within the test phase (1 step = 2.5 seconds).

Specifications

Mains voltage	AC 220 V -15 %...240 V +10 % AC 100 V -15 %...110 V +10 % Mains frequency 50 Hz -6 %...60 Hz +6 %
Power consumption	
- during the test	3.5 VA
- during burner operation	2.5 VA
Prefuse (externally)	T16/500 V
Unit fuse	T6,3H250 V to IEC 127
Radio interference protection	N to VDE 0875
Perm. input current at terminal	15 A continuous to VDE 0660 AC3
Environmental conditions:	
Temperature	-50...+60 °C
Humidity	< 95 % r.h.
Mechanical conditions	class 2M2
Climatic conditions	class 3K5
Temperature	-20...+60 °C
Humidity	< 95 % r.h.
Condensation, formation of ice and influence of water	are not permitted
Perm. current rating of control terminals	4 A to VDE 0660 AC3
Required switching capacity of pressure switch "DW"1 A min.,	AC 250 V
Mounting position	optional
Degree of protection	IP40
Weight	
control unit approx.	1000 g
base approx.	165 g
CE conformity	According to the directives of the European Community
Electromagnetic compatibility	EMC 89/336
EWG include. 92/31 EEC, Gas appliance directive 90/396 EEC	
Emissions	EN 50081-1
Immunity	EN 50082-2

- ▶ Start position = operating position
- In plants without a vent valve: evacuation of test space through opening of the valve on the burner side
- Test 1** "Test 1" with atmospheric pressure (valve proving test on the mains side)
- Filling the test space through opening of the valve on the mains side
- Test 2** "Test 2" with gas pressure (valve proving test on the burner side)
- | | | Idle steps until programming mechanism switches itself off
- ▶ Operating position = start position for the next valve proving test

In the event of lockout, all terminals receiving voltage from the control unit are de-energized, except terminal 13, which is used for lockout indication. After the unit has been reset, the programming mechanism automatically returns to its

start position and immediately reprograms a new valve proving test.

Note: do not press the reset button for more than 10 seconds.

Control program after a power failure

A power failure prior to evacuating the test space does not cause the program sequence to change.

If a power failure occurs after the evacuation, the valve proving test will not be continued when power is restored, but the programming mechanism first returns to its start position to reprogram the complete proving test.

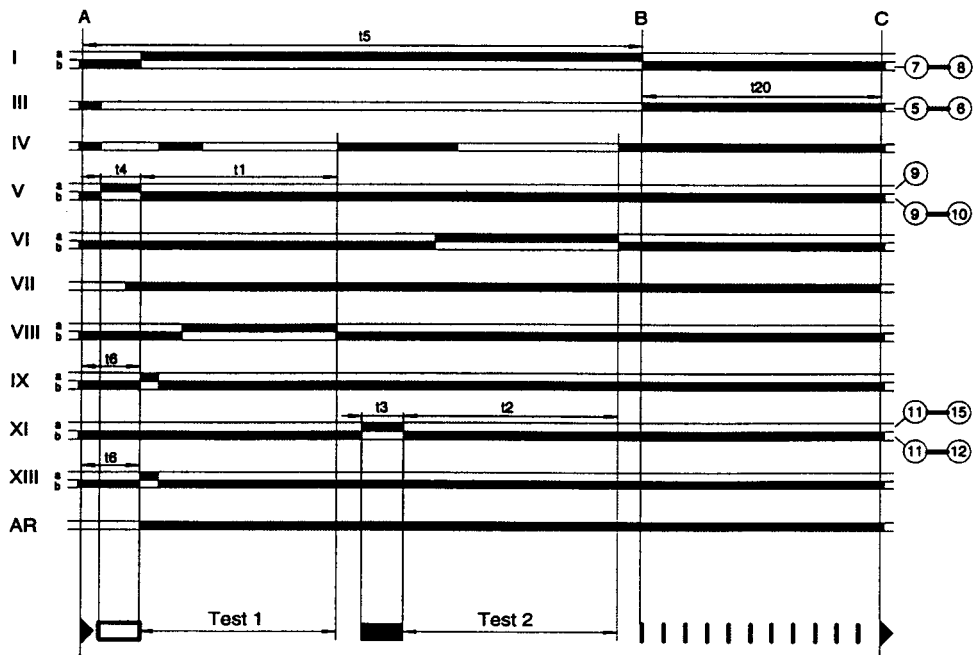
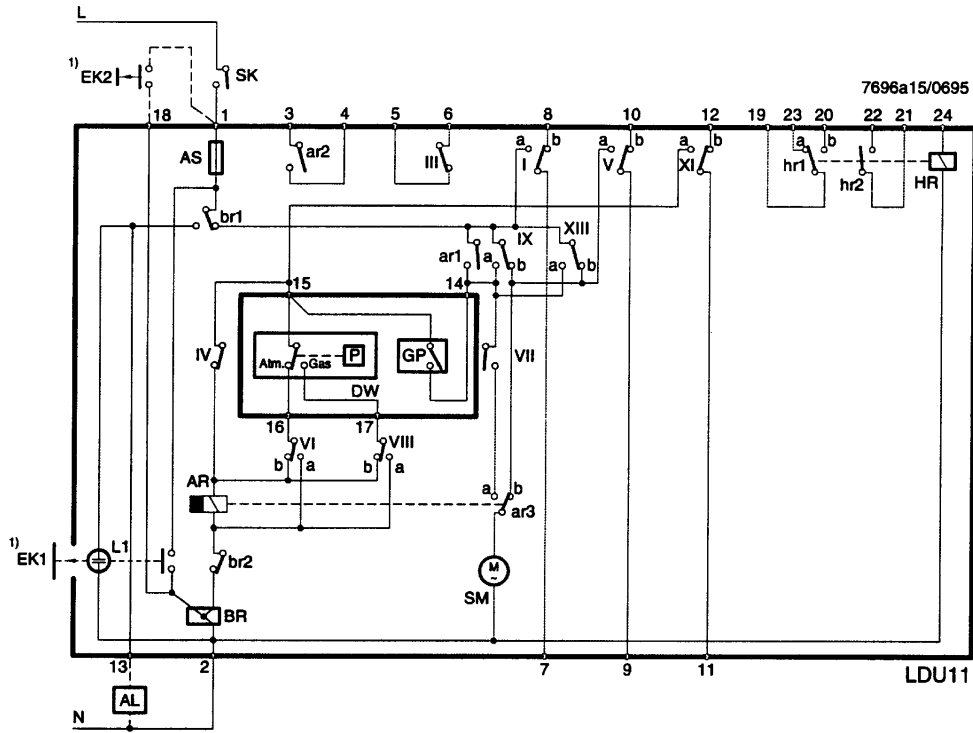

KEY

- AL Alarm signal "Leaking valve"
- AR Main relay with contacts "ar..."
- AS Built-in fuse
- BR Lockout relay with contacts "br..."
- DW Pressure monitor for valve proving test (does not replace the gas pressure monitor used to signal lack of gas)
- EK... Lockout reset button
- GP Gas pressure monitor (for lack of gas)
- HR Auxiliary relay with contacts "hr..."
- L1 Built-in lockout warning lamp
- SM Synchronous motor of programming mechanism
- SK Mains switch

Warning notes

- The electrical wiring must comply with local and country-specific standards and regulations!
- The LDU11... must be completely isolated from the mains before per-

forming any work on it!

- The LDU11... is a safety device. It is therefore not permitted to open, interfere with or modify the unit!
- Check wiring carefully before putting the unit into operation!
- Check all safety functions when putting the unit into operation or after replacing a fuse!
- Ensure protection against electric shock hazard on the unit and at all electrical connections through appropriate mounting!
- Electromagnetic emissions must be checked from an application point of view!
- The regulations and standards covering the specific application must be observed!
- All installation and commissioning work must be carried out by qualified personnel!
- In the geographical areas where DIN standards are in use, the installation must be in compliance with VDE requirement, particularly with the standards DIN/VDE 0100 and 0722!
- Condensation and ingress of humidity must be avoided!
- Ignition cable must always be laid separately, observing the greatest possible distance to other cables!







C.I.B. UNIGAS S.p.A.
Via L.Galvani, 9 - 35011 Campodarsego (PD) - ITALY
Tel. +39 049 9200944 - Fax +39 049 9200945/9201269
web site: www.cibunigas.it - e-mail: cibunigas@cibunigas.it

Note: specifications and data subject to change without notice. Errors and omissions excepted.